

# **PROGRAM CURRICULUM**

(Applicable for the batches admitted from A.Y 2025-26)

**THREE YEAR U.G PROGRAM**

**BACHELOR OF BUSINESS ADMINISTRATION  
(BUSINESS ANALYTICS)**

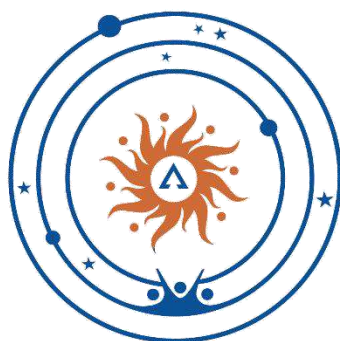

**A D I T Y A**  
**U N I V E R S I T Y**

Aditya Nagar, ADB Road, Surampalem, Andhra Pradesh

## **VISION & MISSION OF THE UNIVERSITY**

### **VISION**

To be a globally recognized University through excellence in Education, Innovation, and Sustainable Growth

### **MISSION**

Deliver collaborative education to prepare students for global challenges through

1. Transformative learning.
2. Vibrant research ecosystem.
3. Sustainable and inclusive community

## **VISION & MISSION OF THE SCHOOL OF BUSINESS**

### **VISION**

To be a world-class business school advancing academic excellence, innovation, and global talent to develop responsible leaders shaping an inclusive and sustainable future

### **MISSION**

**M1:** Deliver transformative business education that blends academic rigor with real-world relevance and ethical grounding.

**M2:** Nurture globally competent, entrepreneurial leaders through innovation, research, and interdisciplinary learning.

**M3:** Champion sustainability, social impact, and inclusive growth through collaborative industry and community engagement.

## PROGRAM OUTCOMES (POs)

After successful completion of the program,

<b>PO1:</b>	<b>Proficiency in Business Fundamentals:</b> Graduates will showcase a thorough grasp of essential business concepts, models, and practices spanning multiple functional areas of management.
<b>PO2:</b>	<b>Competence in Solving Business Challenges:</b> Graduates will effectively diagnose and resolve complex business issues by applying research tools, data interpretation, and strategic decision-making approaches.
<b>PO3:</b>	<b>Logical and Analytical Reasoning:</b> Graduates will demonstrate the capacity to critically assess business scenarios, apply structured thinking, and arrive at reasoned, evidence-based conclusions.
<b>PO4:</b>	<b>Strong Communication Skills:</b> Graduates will be able to articulate ideas clearly and confidently through both written and spoken communication, suitable for diverse professional contexts including presentations, reports, and negotiations.
<b>PO5:</b>	<b>Legal Awareness and Ethical Integrity:</b> Graduates will understand and apply business laws, uphold ethical standards in decision-making, and recognize the importance of corporate governance and compliance.
<b>PO6:</b>	<b>Leadership and Team Engagement:</b> Graduates will develop key leadership attributes, including the ability to guide, influence, and collaborate with teams while embracing adaptability and shared problem-solving.
<b>PO7:</b>	<b>Entrepreneurial Orientation:</b> Graduates will embody entrepreneurial thinking, demonstrating originality, proactive innovation, and the ability to pursue and develop new business ventures or opportunities.
<b>PO8:</b>	<b>Commitment to Human Values:</b> Graduates will integrate core human values such as honesty, empathy, harmony, and scientific curiosity into their personal and professional conduct, promoting ethical and socially conscious leadership.
<b>PO9:</b>	<b>Digital and Technological Literacy:</b> Graduates will possess the ability to leverage digital tools, business technologies, and analytics platforms to enhance decision-making and organizational efficiency.
<b>PO10:</b>	<b>Teamwork and Global Business Dynamics:</b> Graduates will work productively within diverse and cross-cultural teams, contributing effectively to collective goals through cooperation, shared responsibility, and mutual respect, while demonstrating awareness of international business trends, cultural nuances, and the economic impact of globalization on business practices.
<b>PO11:</b>	<b>Lifelong Learning Orientation:</b> Graduates will exhibit a proactive attitude toward continuous learning, professional growth, and staying aligned with evolving industry practices and innovations.

## PROGRAM SPECIFIC OUTCOMES (PSOs)

After successful completion of the program,

- PSO1: Analytical Thinking and Tool Application:** Graduates will demonstrate proficiency in using analytical tools and technologies (Excel, SQL, R/Python, Tableau, Power BI) for solving real-world business problems across domains.
- PSO2: Data Interpretation and Strategic Decision-Making:** Graduates will be able to gather, clean, visualize, and interpret data to make strategic and operational decisions in business functions such as marketing, finance, and supply chain.
- PSO3: Business Intelligence with Ethical Insight:** Graduates will apply business intelligence techniques responsibly, ensuring data integrity, compliance, and ethical use of information in line with contemporary data

## PROGRAM EDUCATIONAL OBJECTIVES (PEOs)

After successful completion, this program will support

- PEO 1: Strong Foundation in Business Disciplines:** To equip students with comprehensive knowledge across essential business domains such as accounting, finance, marketing, operations, and management, fostering a robust understanding of core principles that drive business success.
- PEO 2: Development of Analytical and Problem-Solving Skills:** To build students' capacity for critical thinking and logical analysis, enabling them to address complex business challenges through informed decision-making and data-driven solutions.
- PEO 3: Mastery in Communication:** To strengthen students' written, verbal, and interpersonal communication skills, preparing them to articulate ideas clearly, craft professional business documents, and deliver impactful presentations.
- PEO 4: Fostering Collaboration and Leadership:** To instill a strong appreciation for teamwork and cooperative problem-solving, while also nurturing leadership abilities that empower students to effectively manage group dynamics and drive collective success.
- PEO 5: Encouraging Innovation and Entrepreneurial Thinking:** To inspire a spirit of innovation and cultivate an entrepreneurial outlook, encouraging students to think creatively, embrace risk, and recognize emerging opportunities in the business landscape.
- PEO 6: Commitment to Lifelong Learning and Growth:** To promote an enduring commitment to personal and professional development by encouraging students to remain agile, pursue advanced learning, and adapt continuously in a fast-changing business environment.

**Bachelor of Business Administration (BBA-BA)  
 Program Curriculum-2025**

**Credit Division:**

<b>S. No</b>	<b>Category of Courses</b>	<b>Credits</b>
1	Program Core Courses (PCC)	48
2	Discipline Specific Courses (DSC)	30
3	Ability Enhancement Courses (AEC)	05
4	Multi-Disciplinary Course (MDC)	05
5	Value Added Courses (VAC)	12
6	Skill Enhancement Courses (SEC)	12
7	Summer Internship (SI)	04
8	Capstone Project (CPROJ)	04
10	Mandatory courses (MC)	0
<b>Total Credits</b>		<b>120</b>

**FC-** Fundamental Courses

**IC-** Intermediate Level Courses

**AC-** Advanced Courses

### Program Core Courses (PCC)

Course Code	Course Title	Level	L	T	P	C	CIE	SEE	Total	Pre-requisite
2507BA34	Principles and Practices of Management	FC	2		1	3	50	50	100	-
2507BA24	Financial Accounting	FC	2	1		3	50	50	100	-
2507BA21	Business Statistics and Logic	FC	2	1		3	50	50	100	-
2507BA32	Micro economics	FC	2		1	3	50	50	100	-
2507BA40	Human Behavior and Organization	IC	2		1	3	50	50	100	PPM
2507BA30	Marketing Management	FC	2		1	3	50	50	100	-
2507BA42	Macro Economics	IC	2		1	3	50	50	100	MiE
2507BA29	Legal and Ethical Issues in Business	FC	2		1	3	50	50	100	FA
2507BA19	Business Environment and Public Policy	FC	2		1	3	50	50	100	-
2507BA33	Operations Management	FC	2		1	3	50	50	100	-
2507BA20	Business Research Methodology	FC	2	1		3	50	50	100	-
2507BA35	Strategic Management	FC	2		1	3	50	50	100	-
2507BA12	Logistics and Supply Chain Management	IC	2		1	3	50	50	100	MM
2507BA27	Intellectual Property Rights	FC	2		1	3	50	50	100	-
2507BA15	Project Management	AC	2		1	3	50	50	100	OM
2507BA02	Business Taxation	AC	2	1		3	50	50	100	-
	<b>Total</b>					<b>48</b>				

### Discipline Specific Courses (DSC)

<b>Business Analytics (BA)</b>											
<b>S. No</b>	<b>Course Code</b>	<b>Course Title</b>	<b>Level</b>	<b>L</b>	<b>T</b>	<b>P</b>	<b>C</b>	<b>CIE</b>	<b>SEE</b>	<b>Total</b>	<b>Pre-requisite</b>
I	2507BA11	Introduction to Business Analytics	AC	2		1	3	50	50	100	-
II	2507BA05	Data Analysis with Python	AC	2		1	3	50	50	100	IBA
III	2507BA13	Marketing Analytics	AC	2		1	3	50	50	100	
IV	2507BA09	Financial Analytics	AC	2		1	3	50	50	100	
V	2507BA10	HR Analytics	AC	2		1	3	50	50	100	
VI	2507BA14	Predictive Analytics	AC	2		1	3	50	50	100	
VII	2507BA01	Big Data Analytics	AC	2		1	3	50	50	100	
VIII	2507BA18	Web Analytics	AC	2		1	3	50	50	100	
IX	2507BA06	Data Mining and Machine Learning	AC	2		1	3	50	50	100	
X	2507BA07	Data Visualization	AC	2		1	3	50	50	100	
<b>Total</b>							<b>30</b>				

### Ability Enhancement Courses (AEC)

Course Code	Course Title	Level	L	T	P	C	CIE	SEE	Total	Pre-requisite
2507BA25	Fundamental Cognitive Skills for Managers	FC			1	1	100	-	-	-
2507BA36	Advanced Cognitive Skills for Managers	IC			1	1	100	-	-	FCSM
2507BA08	Employability Skills V	AC				1	100	-	-	ES-IV
2507BA16	Student Activity-Based Learning	AC				2	-	-	-	-

### Multi-Disciplinary Course (MDC)

Course Code	Course Title	Level	L	T	P	C	CIE	SEE	Total	Pre-requisite
2507BA28	IT & AI Skills	FC	1		2	3	100	-	100	-
2507BA31	Media Literacy and Critical Thinking	FC	2			2	50	50	100	-

### Value Added Courses (VAC)

Course Code	Course Title	Level	L	T	P	C	CIE	SEE	Total	Pre-requisite
2507BA23	Environmental Science and Sustainability	FC	2			2	50	50	100	-
2507BA26	Indian constitution	FC	2			2	50	50	100	-
2507BA44	Public Health and Management	FC	2			2	50	50	100	-
2507BA37	Community Service Project	FC			3	3	100	-	100	-
2507BA41	International Business	IC	2		1	3	50	50	100	BEPP

### Skill Enhancement Courses (SEC)

Course Code	Course Title	Level	L	T	P	C	CIE	SEE	Total	Pre-requisite
2507BA22	Emerging Technologies and Applications	IC	2			2	50	50	100	IT&AIS
2507BA43	Management Information System	AC	2		1	3	50	50	100	ETA
2507BA39	Enterprise Systems and Platforms	IC	2		1	3	50	50	100	IT&AI
2507BA38	Design Thinking and Innovation	FC	2			2	50	50	100	-
2507BA04	Corporate Governance	AC	2			2	50	50	100	BEPP

### Summer Internship (SI)

Course Code	Course Title	Level	L	T	P	C	CIE	SEE	Total	Pre-requisite
2507BA17	Summer Internship	IC			4	4	100	-	100	-

### Capstone Project (CPROJ)

Course Code	Course Title	Level	L	T	P	C	CIE	SEE	Total	Pre-requisite
2507BA03	Capstone Project	AC			4	4	50	50	100	-

### Mandatory Courses (MC)

Course Code	Course Title	Level	L	T	P	C	CIE	SEE	Total	Pre-requisite
2507AC01	Employability Skills-I	AC	2				100	-	100	-
2507AC02	Employability Skills-II	AC	2				100	-	100	ES-I
2507AC03	Employability Skills-III	AC	2				100	-	100	ES-II
2507AC04	Employability Skills-IV	AC	2				100	-	100	ES-III

**2025 BBA BA CURRICULUM**  
**Pre - Requisite Flow Chart**

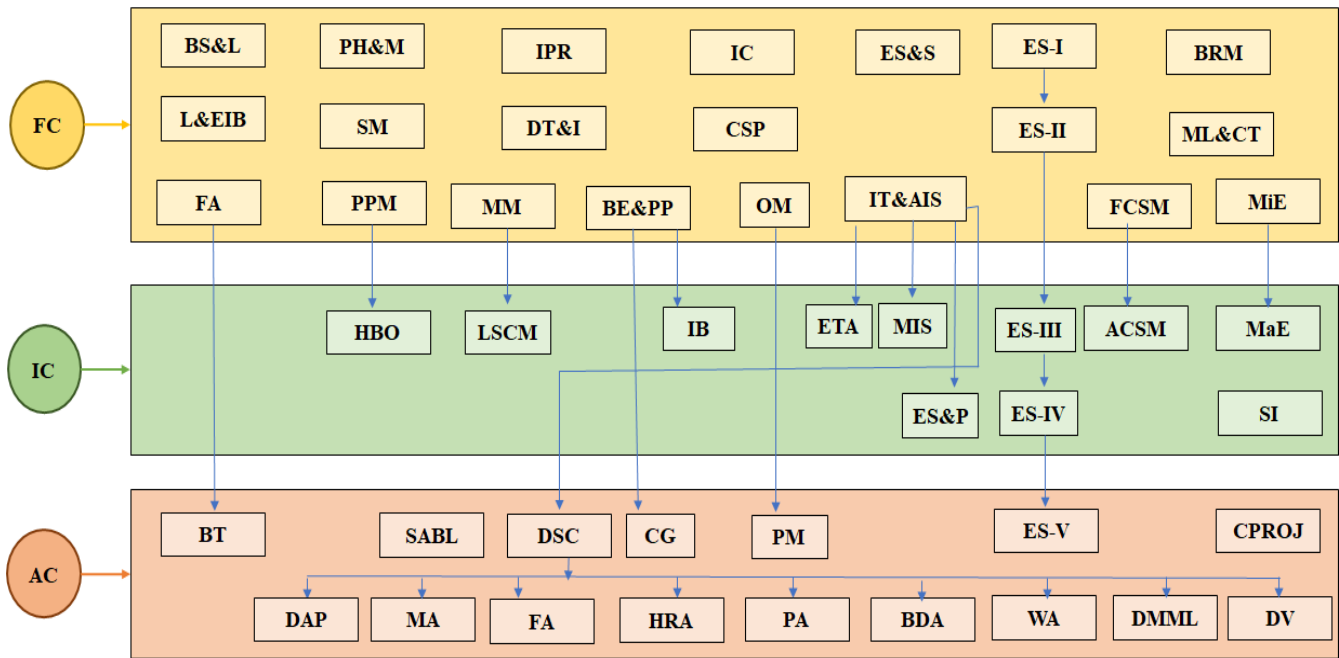

<b>Fundamental Courses</b>	
<b>PPM</b>	Principles and Practices of Management
<b>FA</b>	Financial Accounting
<b>BS&amp;L</b>	Business Statistics and Logic
<b>MiE</b>	Micro economics
<b>MM</b>	Marketing Management
<b>L&amp;EIB</b>	Legal and Ethical Issues in Business
<b>BEPP</b>	Business Environment and Public Policy
<b>OM</b>	Operations Management
<b>BRM</b>	Business Research Methodology
<b>SM</b>	Strategic Management
<b>IPR</b>	Intellectual Property Rights
<b>FCSM</b>	Fundamental Cognitive Skills for Managers
<b>IT&amp;AI</b>	IT & AI Skills
<b>ML&amp;CT</b>	Media Literacy and Critical Thinking
<b>ES&amp;S</b>	Environmental Science and Sustainability
<b>IC</b>	Indian constitution
<b>PH&amp;M</b>	Public Health and Management
<b>CSP</b>	Community service Project
<b>DT&amp;I</b>	Design Thinking and Innovation
<b>ES-I</b>	Employability Skills-I
<b>ES-II</b>	Employability Skills-II

<b>Intermediate Level Courses</b>	
<b>HBO</b>	Human Behavior and Organization
<b>MaE</b>	Macro Economics
<b>L&amp;SCM</b>	Logistics and Supply Chain Management
<b>ACSM</b>	Advanced Cognitive skills for Managers
<b>IB</b>	International Business
<b>ET&amp;A</b>	Emerging Technologies and Applications
<b>ER&amp;P</b>	Enterprise System and Platforms
<b>SI</b>	Summer Internship
<b>ES-III</b>	Employability Skills-III
<b>ES-IV</b>	Employability Skills-IV

<b>Advanced Courses</b>	
<b>PM</b>	Project Management
<b>BT</b>	Business Taxation
<b>MIS</b>	Management Information System
<b>CG</b>	Corporate Governance
<b>ES-V</b>	Employability Skills V
<b>SCBL</b>	Student Activity Based Learning
<b>CPROJ</b>	Capstone Project
<b>Discipline Specific Courses (DSC)</b>	
<b>BA</b>	Business Analytics

### Suggestive Semester- wise Curriculum

<b>SEMESTER-I</b>									
Course Code	Course Title	Level	Course Category	Credits				Total Hours	Pre requisite
				L	T	P	Total		
2507BA34	Principles and Practices of Management	FC	PCC	2		1	3	4	-
2507BA24	Financial Accounting	FC	PCC	2	1		3	3	-
2507BA21	Business Statistics and Logic	FC	PCC	2	1		3	3	-
2507BA32	Micro economics	FC	PCC	2		1	3	4	-
2507BA11	Introduction to Business Analytics	AC	DSC	2		1	3	4	-
2507BA23	Environmental Science and Sustainability	FC	VAC	2			2	2	-
2507BA28	IT & AI Skills	FC	MDC	1		2	3	5	-
2507BA25	Fundamental Cognitive skills for Managers	FC	AEC			1	1	2	-
2507AC01	Employability Skills I	FC	MC	2				3	-
<b>Total</b>							<b>21</b>	<b>30</b>	

<b>SEMESTER-II</b>									
Course Code	Course Title	Level	Course Category	Credits				Total Hours	Pre requisites
				L	T	P	Total		
2507BA40	Human Behavior and Organization	IC	PCC	2		1	3	4	PPM
2507BA30	Marketing Management	FC	PCC	2		1	3	4	-
2507BA42	Macro Economics	IC	PCC	2		1	3	4	MiE
2507BA05	Data Analysis with Python	AC	DSC	2		1	3	4	IBA
2507BA26	Indian constitution	FC	VAC	2			2	2	-
2507BA22	Emerging Technologies and Applications	IC	SEC	2			2	2	IT&AI
2507BA31	Media Literacy and Critical Thinking	FC	MDC	2			2	2	-
2507BA36	Advanced Cognitive skills for Managers	IC	AEC			1	1	2	FCSM
2507AC02	Employability Skills II	FC	MC	2				3	ES-I
<b>Total</b>							<b>20</b>	<b>27</b>	

SEMESTER-III									
Course Code	Course Title	Level	Course Category	Credits				Total Hours	Pre requisite
				L	T	P	Total		
2507BA29	Legal and Ethical Issues in Business	FC	PCC	2		1	3	4	-
2507BA19	Business Environment and Public Policy	FC	PCC	2		1	3	4	-
2507BA13	Marketing Analytics	AC	DSC	2		1	3	4	IBA
2507BA09	Financial Analytics	AC	DSC	2		1	3	4	IBA
2507BA43	Management Information System	AC	SEC	2		1	3	4	ETA
2507BA44	Public Health and Management	FC	VAC	2			2	2	-
2507BA37	Community service Project	FC	VAC			3	3	-	-
2507AC03	Employability Skills III	IC	MC	2				3	ES-II
<b>Total</b>							<b>20</b>	<b>25</b>	

SEMESTER-IV									
Course Code	Course Title	Level	Course Category	Credits				Total Hours	Pre requisite
				L	T	P	Total		
2507BA33	Operations Management	FC	PCC	2		1	3	4	
2507BA20	Business Research Methodology	FC	PCC	2	1		3	3	
2507BA10	HR Analytics	AC	DSC	2		1	3	4	IBA
2507BA07	Data Visualization	AC	DSC	2		1	3	4	IBA
2507BA41	International Business	IC	VAC	2		1	3	4	BE
2507BA39	Enterprise System and Platforms	IC	SEC	2		1	3	4	IT&AI
2507BA38	Design Thinking and Innovation	FC	SEC	2			2	2	-
2507AC04	Employability Skills IV	IC	MC	2				3	ES-III
<b>Total</b>							<b>20</b>	<b>28</b>	

SEMESTER-V									
Course Code	Course Title	Level	Course Category	Credits				Total Hours	Pre requisite
				L	T	P	Total		
2507BA35	Strategic Management	FC	PCC	2		1	3	4	-
2507BA12	Logistics and Supply chain Management	AC	PCC	2		1	3	4	MM
2507BA27	Intellectual Property Rights	FC	PCC	2		1	3	4	-
2507BA14	Predictive Analytics	AC	DSC	2		1	3	4	IBA
2507BA01	Big Data Analytics	AC	DSC	2		1	3	4	IBA
2507BA17	Summer Internship	IC	SI			4	4		-
2507BA08	Employability Skills V	AC	AEC				1	3	ES-IV
<b>Total</b>							<b>20</b>	<b>23</b>	

SEMESTER-VI									
Course Code	Course Title	Level	Course Category	Credits				Total Hours	Pre requisite
				L	T	P	Total		
2507BA15	Project Management	AC	PCC	2		1	3	4	OM
2507BA02	Business Taxation	AC	PCC	2	1		3	3	FA
2507BA18	Web Analytics	AC	DSC	2		1	3	4	IBA
2507BA06	Data Mining and Machine Learning	AC	DSC	2		1	3	4	IBA
2507BA04	Corporate Governance	AC	SEC	2			2	2	BE
2507BA03	Capstone Project	AC	CPROJ			4	4		-
2507BA16	Student Activity Based Learning	AC	AEC				2		-
<b>Total</b>							<b>20</b>	<b>17</b>	

**PROGRAM CORE COURSES**  
**PRINCIPLES AND PRACTICES OF MANAGEMENT**

**Course Code: 2507BA34** **L T P C**  
**2 1 3**

**Course Outcomes:**

**At the end of the course, Student will be able to:**

- CO1:** Explain theoretical aspects, processes and principles, the scope of Management and its application to modern management practice
- CO2:** Identify the Decision-making process in Business organizations
- CO3:** Differentiate the functions of Line and Staff management
- CO4:** Understand and apply different leadership styles
- CO5:** Apply different controlling techniques in different situations

**Mapping of Course Outcomes with Program Outcomes:**

CO / PO	PO1	PO2	PO3	PO4	PO5	PO6	PO7	PO8	PO9	PO10	PO11
<b>CO1</b>	3	2	2	1	1	1	-	2	1	1	1
<b>CO2</b>	2	3	3	1	1	2	1	1	2	1	1
<b>CO3</b>	2	2	2	1	1	3	-	1	1	2	1
<b>CO4</b>	1	2	2	2	1	3	1	2	1	2	2
<b>CO5</b>	2	3	3	1	1	2	-	1	2	1	2

**Mapping of Course Outcomes with Program Specific Outcomes:**

CO / PSO	PSO1	PSO2	PSO3
<b>CO1</b>	2	1	1
<b>CO2</b>	2	2	2
<b>CO3</b>	2	2	1
<b>CO4</b>	1	2	1
<b>CO5</b>	2	2	2

**UNIT – I**

**Management:** Definition, nature, significance and principles of management, Evolution of management thought, management and administration, levels of management, Functions of Management.

**UNIT – II**

**Planning:** Concept, Objectives, Types, Steps and Techniques, Decision Making: Steps in Decision Making and Types; Management by Objectives (MBO).

**UNIT – III**

**Organizing & Staffing:** Structures, Nature, Types and Principles of Organizing; Centralization and Decentralization, Staffing: Nature, Significance and Process.

**UNIT – IV**

**Leading and Directing:** Introduction, Characteristics and Functions of a Leader; Leadership and Management, Styles of Leaders. **Directing:** Meaning and nature and importance of Directing.

**UNIT – V**

**Controlling:** Introduction, Concept of Controlling, Purpose of Controlling; Types of Control; Steps in Controlling; Techniques in Controlling.

**Textbooks:**

1. P.C. Tripathi & P.N. Reddy, Principles of Management (2023), McGraw Hill, 6th Edition, ISBN: 9789352605354
2. Harold Koontz & Heinz Weihrich, Essentials of Management (2015), McGraw Hill, 10th Edition, ISBN: 9789339222864

**Reference Books:**

1. Gerald Cole, Management: Theory and Practice (2020), Cengage, ISBN: 9781473769724
2. OpenStax, Principles of Management (2019) XanEdu Publishing Inc, Ed., ISBN: 9781593998769

**Web Links:**

1. [https://onlinecourses.nptel.ac.in/noc23\\_mg33/preview](https://onlinecourses.nptel.ac.in/noc23_mg33/preview)
2. <https://archive.nptel.ac.in/courses/110/107/110107150/>

**Relevant cases have to be discussed in each unit and in examination case study is compulsory from any unit.**

## FINANCIAL ACCOUNTING

**Course Code: 2507BA24**

<b>L</b>	<b>T</b>	<b>P</b>	<b>C</b>
<b>2</b>	<b>1</b>		<b>3</b>

### Course Outcomes:

**At the end of the Course, Student will be able to:**

- CO1:** Identify and explain key concepts and principles of financial accounting.
- CO2:** Assess accounting concepts, principles, standards, and policies.
- CO3:** Apply the accounting process to record transactions and compute depreciation.
- CO4:** Simplify Trading, Profit & Loss Accounts, and Balance Sheets for sole proprietary businesses.
- CO5:** Analyze final accounts of companies in line with the Companies Act, 2013

### Mapping of Course Outcomes with Program Outcomes:

CO / PO	PO1	PO2	PO3	PO4	PO5	PO6	PO7	PO8	PO9	PO10	PO11
<b>CO1</b>	3	2	2	1	2	-	-	1	1	-	1
<b>CO2</b>	3	3	2	1	3	-	-	1	2	-	1
<b>CO3</b>	3	3	2	1	2	-	-	1	2	-	1
<b>CO4</b>	3	2	2	1	2	-	-	1	1	1	1
<b>CO5</b>	3	3	2	1	3	-	-	2	2	1	2

### Mapping of Course Outcomes with Program Specific Outcomes:

CO / PSO	PSO1	PSO2	PSO3
<b>CO1</b>	3	2	2
<b>CO2</b>	3	3	2
<b>CO3</b>	3	3	2
<b>CO4</b>	3	2	2
<b>CO5</b>	3	3	3

### UNIT – I

**Introduction to Financial Accounting:** Definition, Scope, objectives of Financial Accounting, Accounting v/s Book Keeping, Double entry system of accounting and its advantages; types of accounts, rules of accounting.

### UNIT – II

**Conceptual Frame work:** Accounting Concepts, Principles and Conventions, Brief review of Accounting Standards in India, GAAP (Generally Accepted Accounting Principles) and IFRS (International Financial Reporting Standards)

### UNIT – III

**Recording of Transactions:** Voucher system; Accounting Process, Journal, Subsidiary Books, Ledger, Cash Book, Bank Reconciliation Statement, Trial Balance. Rectification of Errors; Depreciation: Need & importance and methods of charging depreciation,

#### **UNIT – IV**

**Preparation of Final Accounts:** Preparation of Trading and Profit & Loss Account and Balance Sheet of sole proprietary business (with adjustments).

#### **UNIT – V**

**Company Final Accounts:** Understanding of final accounts of a Company. Joint Stock Company- Definition, Characteristics, types of companies, Shares, Share Capital, rights shares, bonus shares.

#### **Textbooks:**

1. T.S. Grewal, Double Entry Book Keeping: Financial Accounting(2023), Sultan Chand & Sons, ISBN: 9788196162658
2. Ambrish Gupta, Financial Accounting for Management (2021), Pearson, 5th Edition, ISBN: 9788131797556

#### **Reference Books:**

1. Rajesh Agarwal & R. Srinivasan, Accounting Made Easy (2020) McGraw Hill, 2nd Edition, ISBN: 9780070700987
2. R. Narayanaswamy, Financial Accounting: A Managerial Perspective (2017) PHI, 6th Edition, ISBN: 9788120353435

#### **Web Links:**

1. [https://onlinecourses.nptel.ac.in/noc23\\_mg65/preview](https://onlinecourses.nptel.ac.in/noc23_mg65/preview)
2. <https://archive.nptel.ac.in/courses/110/101/110101131/>

**Relevant cases have to be discussed in each unit and in examination case study is compulsory from any unit.**

## BUSINESS STATISTICS AND LOGIC

**Course Code: 2507BA21**

<b>L</b>	<b>T</b>	<b>P</b>	<b>C</b>
2	1		3

**Course Outcomes:**

**At the end of the Course, students will be able to:**

- CO1:** Explain the types of data and types of variables
- CO2:** Interpret various concepts of descriptive statistics
- CO3:** Analyze the theories of probability
- CO4:** Solve the problems related to Linear programming.
- CO5:** Develop various transportation models and game theory.

**Mapping of Course Outcomes with Program Outcomes:**

CO / PO	PO1	PO2	PO3	PO4	PO5	PO6	PO7	PO8	PO9	PO10	PO11
<b>CO1</b>	2	2	2	1	-	-	-	-	2	-	1
<b>CO2</b>	2	3	3	1	-	-	-	-	3	-	1
<b>CO3</b>	2	3	3	1	-	-	-	-	3	-	1
<b>CO4</b>	2	3	3	1	-	1	1	-	3	1	1
<b>CO5</b>	2	3	3	1	-	1	1	-	3	1	1

**Mapping of Course Outcomes with Program Specific Outcomes:**

CO / PSO	PSO1	PSO2	PSO3
<b>CO1</b>	2	2	1
<b>CO2</b>	3	3	2
<b>CO3</b>	3	3	2
<b>CO4</b>	3	3	3
<b>CO5</b>	3	3	3

**UNIT – I**

**Introduction to Business Statistics:** Statistics in Business, Types of data – Nominal, Ordinal, Interval, Ratio. Types of variables.

**UNIT – II**

**Descriptive Statistics:** Measure of central tendency, Measure of variability – Range, interquartile range, standard deviation, variance, coefficient of variation.

**UNIT – III**

**Introduction to Probability:** Theories of probability, Laws of probability, Inverse Probability. Revision of probability: BAYES' RULE, Discrete distribution – Binomial, Poisson, Continuous distribution – Uniform, normal.

**UNIT – IV**

**Introduction to Linear Programming Problems (LP) – LP Formulations – Graphical Solution – Simplex Method**

**UNIT – V**

**Introduction to Logic** Number series, coding decoding and odd man out series, direction sense test, seating arrangements – linear and circular, blood relations, arithmetic and geometric progressions, Inductive and deductive reasoning.

**Textbooks:**

1. Richard I. Levin & David S. Rubin, Statistics for Management (2012) Pearson Education, 7th Edition, ISBN: 9780134762920
2. S.P. Gupta, Business Statistics (2021), Sultan Chand & Sons, Revised Edition, ISBN: 97893516111066

**Reference Books:**

1. Paul Newbold, William Carlson, Betty Thorne, Statistics for Business and Economics (2020) Pearson, 9th Edition, ISBN: 9781292315034
2. Robert stine and Dean foster, Statistics for business: Decision making and Analysis (2017) Pearson, 3rd Edition ISBN: 9780134497167

**Web Links:**

1. <https://archive.nptel.ac.in/courses/110/107/110107114/>
2. <https://archive.nptel.ac.in/noc/courses/noc21/SEM1/noc21-mg07/>

**Relevant cases have to be discussed in each unit and in examination case study is compulsory from any unit.**

## MICRO ECONOMICS

**Course Code: 2507BA32**

<b>L</b>	<b>T</b>	<b>P</b>	<b>C</b>
<b>2</b>	<b>1</b>	<b></b>	<b>3</b>

### Course Outcomes:

**At the end of the Course, Student will be able to:**

- CO1:** Understand the fundamentals of Micro Economics
- CO2:** Apply the knowledge of the mechanics of supply and demand to explain working of markets.
- CO3:** Explain the relationships between production and costs.
- CO4:** Analyze the key characteristics and consequences of different forms of markets.
- CO5:** Examine the choices made by a rational consumer

### Mapping of Course Outcomes with Program Outcomes:

CO / PO	PO1	PO2	PO3	PO4	PO5	PO6	PO7	PO8	PO9	PO10	PO11
<b>CO1</b>	3	2	1	2	-	-	-	-	2	-	1
<b>CO2</b>	3	3	2	2	-	-	1	-	3	-	1
<b>CO3</b>	3	3	2	2	-	-	1	-	3	-	1
<b>CO4</b>	3	3	2	2	1	1	1	-	3	1	1
<b>CO5</b>	3	3	2	2	1	-	1	-	3	1	1

### Mapping of Course Outcomes with Program Specific Outcomes:

CO / PSO	PSO1	PSO2	PSO3
<b>CO1</b>	2	2	1
<b>CO2</b>	3	2	2
<b>CO3</b>	3	2	2
<b>CO4</b>	3	3	2
<b>CO5</b>	3	3	2

### UNIT – I

**Introduction to Economics:** Definition, Nature and Scope of Economics. Micro and Macro Economics, Role of Economics in Decision Making.

### UNIT – II

**Demand Analysis:** Meaning of Demand, Types of Demand, Law of demand, Determinants of Demand, Demand Function, Elasticity of demand- price elasticity of demand. Income elasticity of demand, Cross Elasticity of demand,

### UNIT – III

**Production and Cost Analysis:** Production function, Factors of Production, Types of Production Function, Law of Returns, Law of variable proportions, Isoquants and Iso cost Curves, Cost Concepts, Cost Output Relation (Short Run & Long Run costs).

**UNIT – IV**

**Market Structures:** Perfect competition, monopoly, monopolistic competition, oligopoly basic features, equilibrium price, short run equilibrium of firm/industry, long run equilibrium of firm/industry.

**UNIT – V**

**Consumer's Behavior:** Law of diminishing Marginal Utility Analysis, Indifference Curve Analysis and its Properties; Marginal rate of Substitution, Consumer Equilibrium.

**Textbooks:**

1. Dr. D.M. Mithani, Microeconomics Himalaya Publishing House, ISBN: 978-93-6557- 962-8
2. Pankaj Tandon, Microeconomic Theory Routledge India, ISBN: 978-1032789668

**Reference Books:**

1. Sreejata Banerjee & Robert S. Pindyck, Microeconomics Pearson India,9th Edition, ISBN: 978-9356060128.
2. David Besanko, Ronald Braeutigam, Tamali Chakraborty, Microeconomics: Indian Adaptation, Wiley India, 6th Edition, ISBN: 978-9354249136

**Web Links:**

1. <https://archive.nptel.ac.in/courses/110/104/110104093/>
2. <https://archive.nptel.ac.in/courses/109/104/109104125/>

**Relevant cases have to be discussed in each unit and in examination case study is compulsory from any unit.**

## HUMAN BEHAVIOR AND ORGANIZATION

	<b>L</b>	<b>T</b>	<b>P</b>	<b>C</b>
<b>Course Code: 2507BA40</b>	<b>2</b>		<b>1</b>	<b>3</b>

### Course Outcomes:

**At the end of the Course, Student will be able to:**

- CO1:** Outline the overall perspective on human behavior in the work place.
- CO2:** Demonstrate the importance of motivation in at work place.
- CO3:** Examine the nature of group conflict and its resolution
- CO4:** Identify the impact of culture on individual performance
- CO5:** Analyze the impact of change, assess and manage work stress.

### Mapping of Course Outcomes with Program Outcomes:

COs / POs	PO1	PO2	PO3	PO4	PO5	PO6	PO7	PO8	PO9	PO10	PO11
<b>CO1</b>	3	2	2	2	2	3	1	3	1	3	2
<b>CO2</b>	3	2	2	2	2	3	1	2	1	3	2
<b>CO3</b>	3	3	3	2	2	3	2	3	1	3	2
<b>CO4</b>	2	2	3	3	3	2	1	3	1	3	2
<b>CO5</b>	2	3	3	3	2	3	1	3	2	3	3

### Mapping of Course Outcomes with Program Specific Outcomes:

CO / PSO	PSO1	PSO2	PSO3
<b>CO1</b>	1	1	2
<b>CO2</b>	2	1	2
<b>CO3</b>	2	1	2
<b>CO4</b>	2	1	2
<b>CO5</b>	2	1	2

### UNIT – I

**Introduction to Human Behavior and Organization:** Meaning and importance of Organizational Behavior (OB); Evolution and factors influencing OB; OB models and their relevance in modern organizations.

### UNIT – II

**Individual Behavior:** Personality – Determinants, Type A & B, Big Five traits; Attitude – Components and job-related attitudes; Learning theories and reinforcement; Perception – Process and influencing factors; Values – Terminal and instrumental; Motivation – Early (Maslow, McGregor, Herzberg) and contemporary theories (Self-Determination, Goal-Setting, Reinforcement, Self-Efficacy).

### UNIT – III

**Group and Team Behavior:** Concepts and differences between groups and teams; Five-stage model of group development; Groupthink, group shift, and Indian perspective on group norms; Types of teams and development; Conflict management in groups and virtual/e-teams.

**UNIT – IV**

**Leadership and Power:** Leadership – Concepts, trait and behavioral theories, contingency theories; Contemporary leadership styles (transformational, charismatic, authentic); Mentoring and self-leadership; Cross-cultural leadership comparisons; Bases and types of power.

**UNIT – V**

**Organizational Culture and Stress Management:** Organizational culture – Meaning, functions, and creating ethical cultures; Role of employees in shaping culture; Cross-cultural management in globalized workplaces; Stress – Causes, types, and stress management strategies.

**Textbooks:**

1. L.M. Prasad, Organizational Behaviour, Sultan Chand & Sons, ISBN: 9789351611462.
2. Dr. Kavita Singh, Organizational Behaviour: Text and Cases, Pearson India, ISBN: 9781282652729

**Reference Books:**

1. Nahar Amandeep, Rao PCK, Nigah Rajesh Kumar, Organisational Behaviour( 2021), Sultan Chand & Sons, ISBN: 93-5161-199-8.
2. Jerald Greenberg, Behavior in Organizations, Pearson Education India, 10 Edition, ISBN-10: 92.332556997, ISBN-13: 9332556997-978

**Web Links:**

1. <https://archive.nptel.ac.in/courses/110/106/110106145/>
2. [https://onlinecourses.nptel.ac.in/noc20\\_mg51/preview](https://onlinecourses.nptel.ac.in/noc20_mg51/preview)

**Relevant cases have to be discussed in each unit and in examination case study is compulsory from any unit.**

## MARKETING MANAGEMENT

	<b>L</b>	<b>T</b>	<b>P</b>	<b>C</b>
<b>Course Code: 2507BA30</b>	<b>2</b>		<b>1</b>	<b>3</b>

### Course Outcomes:

**At the end of the Course, Student will be able to:**

- CO1:** Explain marketing and analyze the core marketing concepts
- CO2:** Assess and select market segments based on effective segmentation criteria
- CO3:** Classify products, analyze the product life cycle, and propose strategies for new product development
- CO4:** Develop pricing strategies, explain the relevance of the value chain to marketing, and assess customer lifetime value
- CO5:** Design integrated marketing channels, manage retailing and logistics, and evaluate the effectiveness of various promotional strategies

### Mapping of Course Outcomes with Program Outcomes:

COs / POs	PO1	PO2	PO3	PO4	PO5	PO6	PO7	PO8	PO9	PO10	PO11
<b>CO1</b>	3	2	1	2	2	1	1	2	2	1	1
<b>CO2</b>	3	3	2	2	2	1	1	2	2	2	1
<b>CO3</b>	3	2	2	2	2	1	2	2	2	2	2
<b>CO4</b>	3	3	2	2	2	1	2	2	2	2	1
<b>CO5</b>	3	2	2	2	2	2	2	3	3	2	2

### Mapping of Course Outcomes with Program Specific Outcomes:

CO / PSO	PSO1	PSO2	PSO3
<b>CO1</b>	3	1	1
<b>CO2</b>	3	1	1
<b>CO3</b>	3	1	1
<b>CO4</b>	3	1	1
<b>CO5</b>	3	1	1

### UNIT – I

**Introduction to Marketing and Environment:** Nature, scope, and importance of marketing; Evolution of marketing concepts (Production, Product, Selling, Marketing, Holistic); Types of marketing (B2C, B2G, B2B, C2C); Marketing environment (Demographic, Economic, Political, Legal, Socio-cultural, Technological); Market and competition analysis; Creating customer value.

### UNIT – II

**Consumer Behavior and Market Segmentation:** Segmentation, Targeting, and Positioning; Bases for segmenting consumer markets; Consumer behavior (Stimulus Response Model, Cultural, Social, Personal, Psychological factors); Consumer buying decision process; Business buyer behavior; Traditional vs. Experiential marketing.

### UNIT – III

**Product and Pricing Decisions:** Product Life Cycle (PLC) and marketing strategies; Product classification, line, and mix decisions; Branding, packaging, labeling; BCG Matrix; Brand management; Innovation and new product development; Pricing determinants and methods.

#### **UNIT – IV**

**Promotion and Distribution Decisions:** Promotion mix and factors; Promotional tools (Advertising, Sales Promotion, PR, Publicity, Personal Selling); Marketing channels and intermediaries (Wholesalers, Retailers); Introduction to retail management.

#### **UNIT – V**

**Services and Contemporary Marketing:** Services marketing (7Ps); Contemporary marketing issues (E- commerce, Digital Marketing, Online payments); Ethical and social responsibility; Rural marketing, social marketing, green marketing.

#### **Textbooks:**

1. Kotler, P., Keller, K. L., Chernev. A., Sheth. J.N., Shainesh.G., Marketing Management (2022), Pearson Education, 16th Edition, ISBN-10. 9356062668; ISBN-13. 978-9356062665
2. Dr. K. Karunakaran, Marketing Management, Himalaya Publishing House, ISBN: 978- 93-5693-548-8

#### **Reference Books:**

1. Hartley, S. W., Kerin, R. A., Marketing (2021) United States: McGraw-Hill Education, 15th Edition, ISBN-10. 1260260364; ISBN-13. 978-1260260366
2. Prof. Sunil Tiwari and Dr. Richa Tiwari, Strategic International Marketing, Society Publishing, ISBN: 9781779563798

#### **Web Links:**

1. [https://onlinecourses.nptel.ac.in/noc22\\_mg57/preview](https://onlinecourses.nptel.ac.in/noc22_mg57/preview)
2. <https://archive.nptel.ac.in/courses/110/104/110104068/>

**Relevant cases have to be discussed in each unit and in examination case is compulsory from any unit.**

## MACRO ECONOMICS

**Course Code: 2507BA42**

<b>L</b>	<b>T</b>	<b>P</b>	<b>C</b>
<b>2</b>		<b>1</b>	<b>3</b>

### Course Outcomes:

**At the end of the Course, Student will be able to:**

- CO1:** Explain the concepts of National Income
- CO2:** Identify the Basics of Fiscal policy and its importance
- CO3:** Compare the relationships between monetary policy and flow of cash in economy.
- CO4:** Analyze the key characteristics and consequences of Business cycles and Balance of Payments.
- CO5:** Examine the concepts of inflation and unemployment

### Mapping of Course Outcomes with Program Outcomes:

COs / POs	PO1	PO2	PO3	PO4	PO5	PO6	PO7	PO8	PO9	PO10	PO11
<b>CO1</b>	3	2	1	2	2	1	1	2	1	1	1
<b>CO2</b>	3	3	2	2	2	2	1	2	1	1	1
<b>CO3</b>	3	3	2	2	2	2	2	2	1	1	1
<b>CO4</b>	3	3	2	2	2	2	2	2	1	1	1
<b>CO5</b>	3	3	2	2	2	2	1	2	1	1	1

### Mapping of Course Outcomes with Program Specific Outcomes:

CO / PSO	PSO1	PSO2	PSO3
<b>CO1</b>	2	2	2
<b>CO2</b>	2	3	2
<b>CO3</b>	2	3	2
<b>CO4</b>	2	3	2
<b>CO5</b>	2	3	2

### UNIT – I

**Introduction to Macro Economics and National Income:** Introduction Meaning and Scope of Macro Economics, introduction to Classical and Keynesian theory, Definition, Concepts of National income, Measurement of National Income.

### UNIT – II

**Monetary Policy:** meaning, objectives and components; credit creation; money multiplier; tools of monetary policy- open market operation.

### UNIT – III

**Fiscal Policy:** meaning, objectives and components; revenue receipts, capital receipts, revenue expenditure, capital expenditure, government deficit, revenue deficit, fiscal deficit, primary deficit.

### UNIT – IV

**Business Cycles and Balance of Payments:** Business cycle; phases of business cycle, measures to control Business cycles. Balance of trade, Trade Deficit, Balance of Payments.

### UNIT – V

**Inflation and Unemployment:** Concept of inflation; determinants of inflation; types of inflation; relationship between inflation and unemployment.

**Text Books:**

1. M C Vaish, Macro Economic Theory(2021), Vikas Publishing House, Revised Edition, ISBN: 9788125941958
2. Olivier Blanchard, Macroeconomics(2019), Pearson, 7th Edition, ISBN: 9789353945220

**Reference Books:**

1. Dornbusch, Fischer & Startz, Macroeconomics (2020), McGraw Hill, 13th Edition, ISBN: 9781260084351
2. McConnell, Brue & Flynn, Macroeconomics: Principles, Problems, and Policies (2018), McGraw Hill, 21st Edition, ISBN: 9789353165024

**Web Links:**

1. [https://onlinecourses.swayam2.ac.in/cec22\\_hs08/preview](https://onlinecourses.swayam2.ac.in/cec22_hs08/preview)
2. <https://archive.nptel.ac.in/courses/130/104/130104114/>

**Relevant cases have to be discussed in each unit and in examination case study is compulsory from any unit.**

## LEGAL AND ETHICAL ISSUES IN BUSINESS

	<b>L</b>	<b>T</b>	<b>P</b>	<b>C</b>
<b>Course Code: 2507BA29</b>	<b>2</b>		<b>1</b>	<b>3</b>

### Course Outcomes:

**At the end of the Course, Student will be able to:**

- CO1:** Identify fundamental legal principal behind contractual Agreements
- CO2:** Explain the salient features of Sale of Goods Act and Negotiable Instruments Act
- CO3:** Assume the consequences of applicability of Companies Act and Partnership Act in business situations.
- CO4:** Build critical thinking through the use of Consumer Rights.
- CO5:** Develop awareness in respect of rules and regulations for Environment Protection.

### Mapping of Course Outcomes with Program Outcomes:

COs / POs	PO1	PO2	PO3	PO4	PO5	PO6	PO7	PO8	PO9	PO10	PO11
<b>CO1</b>	3	2	3	2	3	2	2	2	2	2	2
<b>CO2</b>	3	3	2	2	3	2	2	2	2	2	2
<b>CO3</b>	3	3	3	2	3	2	2	2	2	2	2
<b>CO4</b>	3	3	2	2	3	2	2	2	2	2	2
<b>CO5</b>	3	2	2	2	3	2	2	2	2	2	2

### Mapping of Course Outcomes with Program Specific Outcomes:

CO / PSO	PSO1	PSO2	PSO3
<b>CO1</b>	3	2	3
<b>CO2</b>	3	3	2
<b>CO3</b>	3	3	3
<b>CO4</b>	3	3	3
<b>CO5</b>	3	2	3

### UNIT – I

**The Indian Contract Act 1872:** Essentials, types, offer & acceptance, consideration, competency, free consent, void agreements, performance, discharge, breach, quasi contract.

**The Special Contracts:** Indemnity, guarantee, bailment, pledge, agency.

### UNIT – II

**The Sale of Goods Act 1930:** Sale vs. agreement to sell, conditions & warranties, transfer of property, unpaid seller's rights.

**The Negotiable Instruments Act 1881:** Types, parties, dishonor, discharge, promissory note, bill of exchange, cheque.

### UNIT – III

**The Companies Act 2013:** Types, incorporation, MOA & AOA, prospectus, shares, role of directors, company meetings.

**The Limited Liability Partnership Act 2008:** Nature, formation, partners' relations, liability

limitations.

#### **UNIT – IV**

**The Consumer Protection Act 1986:** Consumer rights, disputes, redressal mechanisms.

**The Right to Information Act 2005:** Features, definitions, obligations of authorities, request process, PIO functions.

#### **UNIT – V**

**The Information Technology Act 2000:** Digital signatures, e-governance, cyberlaws.

**The Environment Protection Act 1986:** Water & air pollution, Green Tribunal, sustainability reporting.

#### **Textbooks:**

1. Kenneth W. Clarkson et al., Business Law: Text and Cases (2017), Cengage Learning, 14th Edition, 2017 ISBN: 9781305967250
2. P.C. Tulsian, Business Law (2021), McGraw Hill, 3rd Edition, ISBN: 9789354600318

#### **Reference Books:**

1. Ravinder Kumar, Legal Aspects of Business (2021), Cengage India, 4th Edition, ISBN: 9789387511767
2. N.D. Kapoor, Elements of Mercantile Law (2022), Sultan Chand & Sons, 38th Edition, ISBN: 9789351618323

#### **Web Links:**

1. [https://onlinecourses.swayam2.ac.in/cec21\\_mg02/preview](https://onlinecourses.swayam2.ac.in/cec21_mg02/preview)
2. <https://www.classcentral.com/course/swayam-fundamentals-of-legal-aspects-of-business-22987>

**Relevant cases have to be discussed in each unit and in examination case study is compulsory from any unit.**

## BUSINESS ENVIRONMENT AND PUBLIC POLICY

	<b>L</b>	<b>T</b>	<b>P</b>	<b>C</b>
<b>Course Code: 2507BA19</b>	<b>2</b>		<b>1</b>	<b>3</b>

### Course Outcomes:

**At the end of the Course, Student will be able to:**

- CO1:** Explain the nature, dimensions, and challenges of the business environment at both micro and macro levels.
- CO2:** Explain the global business frameworks and their impact on the Indian economy and national development.
- CO3:** Demonstrate an understanding of key public policies and analyze their impact on the Indian economy and reforms.
- CO4:** Analyze the major economic challenges in India and evaluate remedies and opportunities within the business environment.
- CO5:** Analyze emerging business trends and assess their impact on the digital economy, outsourcing, and technological growth.

### Mapping of Course Outcomes with Program Outcomes:

COs / POs	PO1	PO2	PO3	PO4	PO5	PO6	PO7	PO8	PO9	PO10	PO11
<b>CO1</b>	3	2	2	2	2	2	2	2	2	2	2
<b>CO2</b>	3	2	2	2	2	2	2	2	2	2	2
<b>CO3</b>	3	3	2	2	3	2	2	2	2	2	2
<b>CO4</b>	3	3	2	2	2	2	2	2	2	2	2
<b>CO5</b>	3	3	2	2	3	2	2	2	2	2	2

### Mapping of Course Outcomes with Program Specific Outcomes:

CO / PSO	PSO1	PSO2	PSO3
<b>CO1</b>	3	2	2
<b>CO2</b>	3	3	2
<b>CO3</b>	3	3	3
<b>CO4</b>	3	3	3
<b>CO5</b>	3	3	3

### UNIT – I

**Theoretical Framework of Business Environment:** Concept, Significance and Nature of Business Environment. Micro and Macro Dimensions of Business Environment, Changing Dimensions of Business Environment. Problems and Challenges of Indian Business Environment.

### UNIT – II

**Global Framework:** EPRG Framework, Liberalization, Privatization & Globalization concept & its impact on Indian Economy. Significance of FDI & FII, IMF & WTO, Regional Economic Integrations in the development of the Nations.

### UNIT – III

**Public Policies:** Background, Meaning and Importance of Public Policy. Significance of Industrial Policy, Fiscal Policy, Monetary Policy, Foreign Trade Policy, FERA & FEMA. Structural Adjustment Programs and Banking Sector Reforms in India.

#### **UNIT – IV**

**Problems and Challenges of Growth of Economy:** Unemployment, Poverty, Regional Imbalance. Social Injustice, Inflation, Parallel economy, Lack of technical knowledge and information. Remedies to solve these problems, Challenges & Opportunities of Indian Business Environment.

#### **UNIT – V**

**Emerging Trends in Business:** Concepts, Advantages and Limitations-Franchising, Aggregators, Business Process Outsourcing (BPO) & Knowledge Process Outsourcing (KPO); E-Commerce, Digital Economy. Technological Growth and MNC's.

#### **Textbooks:**

1. Dr. V. Basil Hans, Business Environment, IIP Publications, ISBN: 978-93-5747-517-4
2. Faisal Ahmed & M. Absar Alam, Business Environment: Indian and Global Perspective- PHI Learning, 3rd Edition ISBN: 978-9354437731

#### **Reference Books:**

1. Risha Khandelwa, Business Environment (2024), Toronto Academic Press, ISBN: 978-1774697375
2. Vishwajeet Prasad, Business Environment, GenNext Publication, ISBN: 978-9356633667.

#### **Web Links:**

1. [https://onlinecourses.swayam2.ac.in/imb22\\_mg02/preview](https://onlinecourses.swayam2.ac.in/imb22_mg02/preview)
2. [https://ugcmoocs.inflibnet.ac.in/index.php/courses/view\\_pg/389](https://ugcmoocs.inflibnet.ac.in/index.php/courses/view_pg/389)

**Relevant cases have to be discussed in each unit and in examination case study is compulsory from any unit.**

## OPERATIONS MANAGEMENT

	<b>L</b>	<b>T</b>	<b>P</b>	<b>C</b>
<b>Course Code: 2507BA33</b>	<b>2</b>		<b>1</b>	<b>3</b>

### Course Outcomes:

**At the end of the Course, Student will be able to:**

- CO1:** Understand the Relationship of Operations management with other functional areas and different types of Production Systems.
- CO2:** Apply stages of the product design process, analyze value analysis techniques, and critique facility location and layout decisions
- CO3:** Evaluate methods of forecasting, design operation planning strategies, and assess capacity planning techniques including MRP and scheduling
- CO4:** Analyze factors affecting productivity, apply job design principles, and evaluate process flow charts and methods study
- CO5:** Examine the techniques of Statistical Quality Control and Total Quality Management.

### Mapping of Course Outcomes with Program Outcomes:

COs / POs	PO1	PO2	PO3	PO4	PO5	PO6	PO7	PO8	PO9	PO10	PO11
<b>CO1</b>	3	3	3	3	3	3	2	3	3	3	3
<b>CO2</b>	3	3	3	3	3	3	2	3	3	3	3
<b>CO3</b>	3	3	3	3	3	3	2	3	3	3	3
<b>CO4</b>	3	3	3	3	3	3	2	3	3	3	3
<b>CO5</b>	3	3	3	3	3	3	2	3	3	3	3

### Mapping of Course Outcomes with Program Specific Outcomes:

CO / PSO	PSO1	PSO2	PSO3
<b>CO1</b>	3	3	3
<b>CO2</b>	3	3	3
<b>CO3</b>	3	3	3
<b>CO4</b>	3	3	3
<b>CO5</b>	3	3	3

### UNIT – I

**Introduction to Operation Management:** Nature, Scope, Recent trends in Operation Management, Manufacturing & Theory of Constraint, Types of Production System, Just in Time (JIT) & lean system.

### UNIT – II

**Product Design & Process Selection:** Stages in Product Design process, Value Analysis, Facility location & Layout: Types, Characteristics, Advantages and Disadvantages.

### **UNIT – III**

**Forecasting & Capacity Planning:** Methods of Forecasting, Production strategies, Capacity Requirement Planning, MRP, Scheduling, Supply Chain Management, Purchase Management, Inventory Management.

### **UNIT – IV**

**Productivity:** Factors Affecting Productivity – Job Design – Process Flow Charts – Methods Study – Work Measurement – Engineering and Behavioral Approaches.

### **UNIT – V**

**Quality Management:** Cost of Quality, Quality Circles, ISO (9000&14000 Series), Statistical Quality Control, Control Charts -Acceptance Sampling Operating Characteristic Curve (AQL, LTPD, Alpha & Beta risk), Total Quality Management (TQM).

#### **Textbooks:**

1. Lee J. Krajewski, Manoj K. Malhotra, Operations Management: Processes and Supply (2021) Chains Pearson, 13th Edition, ISBN: 9780136860938
2. William J. Stevenson, Operations Management (2017) McGraw Hill, 13th Edition, ISBN: 9781259667473

#### **Reference Books:**

1. K. Aswathappa & K. Shridhara Bhat, Production and Operations Management (2020), Himalaya Publishing, 2nd Edition, ISBN: 9789352621247
2. S. Anil Kumar, N. Suresh, Operations Management (2018), New Age International, 3rd Edition, ISBN: 9788122437257

#### **Web Links:**

1. [https://onlinecourses.nptel.ac.in/noc20\\_me30/preview](https://onlinecourses.nptel.ac.in/noc20_me30/preview)
2. <https://archive.nptel.ac.in/courses/112/107/112107238/>

**Relevant cases have to be discussed in each unit and in examination case study is compulsory from any unit.**

## BUSINESS RESEARCH METHODOLOGY

	<b>L</b>	<b>T</b>	<b>P</b>	<b>C</b>
<b>Course Code: 2507BA20</b>	<b>2</b>	<b>1</b>		<b>3</b>

### Course Outcomes:

**At the end of the Course, Student will be able to:**

- CO1:** Explain the fundamentals of research, its types, ethical considerations, and the characteristics of good research.
- CO2:** Explain the process of identifying research problems, setting objectives, reviewing literature, and understanding research design types.
- CO3:** Apply appropriate measurement techniques and data collection methods for conducting effective research.
- CO4:** Analyze and evaluate sampling techniques and perform data preparation for effective research analysis.
- CO5:** Analyze and interpret research data using statistical tools and visualization techniques for effective decision-making.

### Mapping of Course Outcomes with Program Outcomes:

COs / POs	PO1	PO2	PO3	PO4	PO5	PO6	PO7	PO8	PO9	PO10	PO11
<b>CO1</b>	3	3	3	3	3	3	2	3	3	3	3
<b>CO2</b>	3	3	3	3	3	3	2	3	3	3	3
<b>CO3</b>	3	3	3	3	3	3	2	3	3	3	3
<b>CO4</b>	3	3	3	3	3	3	2	3	3	3	3
<b>CO5</b>	3	3	3	3	3	3	2	3	3	3	3

### Mapping of Course Outcomes with Program Specific Outcomes:

CO / PSO	PSO1	PSO2	PSO3
<b>CO1</b>	3	3	3
<b>CO2</b>	3	3	3
<b>CO3</b>	3	3	3
<b>CO4</b>	3	3	3
<b>CO5</b>	3	3	3

### UNIT I:

**Introduction to Research:** Definition, history, evolution, and types of research. Scientific inquiry and research ethics. Characteristics of good research and the research process.

### UNIT II:

**Research Problem and Design:** Identifying and formulating research problems, setting objectives, and conducting literature reviews. Basics of research design and types.

**UNIT III:**

**Measurement and Data Collection:** Concepts of measurement and scaling, types of data, measurement errors, and scale construction. Data collection methods: questionnaires, interviews, and observation.

**UNIT IV:**

**Sampling and Data Preparation:** Sampling techniques, sample size, and types of sampling. Data editing, coding, and preparation for analysis.

**UNIT V:**

**Data Analysis and Interpretation:** Hypothesis testing (parametric & non-parametric), tools for analysis, and data visualization techniques such as charts, graphs, and box plots.

**Textbooks:**

1. Dr. C.R. Kothari, Research Methodology & Business Research (2024), Galgotia Publishing Company, ISBN 978-93-90980-48-2.
2. Dr. Zillur Rahman, Business Research Methods, McGraw Hill Education, ISBN: 978-9390177530

**Reference Books:**

1. J.K. Sachdeva, Business Research Methodology (2024), Himalaya Publishing House, ISBN: 978-9352625925
2. H.K. Dangi & Shruti Dewen, Business Research Methods (2024), Vikas Publishing House (Imprint of S. Chand Publishing), 2nd Edition, ISBN: 978-9359307107.

**Web Links:**

1. [https://onlinecourses.swayam2.ac.in/cec20\\_mg14/preview](https://onlinecourses.swayam2.ac.in/cec20_mg14/preview)
2. <https://archive.nptel.ac.in/courses/110/107/110107080/>

**Relevant cases have to be discussed in each unit and in examination case is compulsory from any unit.**

## STRATEGIC MANAGEMENT

	<b>L</b>	<b>T</b>	<b>P</b>	<b>C</b>
<b>Course Code: 2507BA35</b>	<b>2</b>		<b>1</b>	<b>3</b>

### Course Outcomes:

**At the end of the Course, Student will be able to:**

- CO1:** Elaborate on the basic concepts and characteristics of Strategic management.
- CO2:** Build skills to develop strategic vision and mission objectives.
- CO3:** Develop knowledge on types of strategies to implement.
- CO4:** Build awareness on various strategy evaluation and controlling approaches
- CO5:** Visualize various strategies for managing global competition

### Mapping of Course Outcomes with Program Outcomes:

COs / POs	PO1	PO2	PO3	PO4	PO5	PO6	PO7	PO8	PO9	PO10	PO11
<b>CO1</b>	3	2	2	2	2	1	1	1	1	2	1
<b>CO2</b>	3	2	3	2	2	2	2	2	2	2	1
<b>CO3</b>	3	2	3	2	2	2	3	1	2	2	1
<b>CO4</b>	3	2	3	2	2	3	2	1	2	2	1
<b>CO5</b>	2	2	3	2	2	2	3	2	2	2	1

### Mapping of Course Outcomes with Program Specific Outcomes:

CO / PSO	PSO1	PSO2	PSO3
<b>CO1</b>	3	2	2
<b>CO2</b>	3	2	2
<b>CO3</b>	3	2	2
<b>CO4</b>	3	2	2
<b>CO5</b>	2	3	2

### UNIT – I

**Strategic Planning:** Definition, importance, and characteristics of strategic decisions. Difference between policy, strategy, and tactics. Strategic planning vs. long-range planning. Overview of strategic management process.

### UNIT – II

**Strategy Formulation:** Mission, vision, and goal setting. Business environment analysis: External and Internal, Strategic analysis tools: BCG Matrix, Ansoff's Product- Market Matrix. Long-term strategy formulation: Market development, product development, diversification, integration, and liquidation.

### UNIT – III

**Strategy Implementation & Corporate Restructuring:** Strategy and structure, managing strategic change, strategic control mechanisms. Management tools: Benchmarking, Reengineering, Balanced Scorecard. Corporate restructuring: Mergers, acquisitions, joint ventures, and strategic alliances.

**UNIT – IV**

**Strategic Evaluation and Control:** Strategic controls, performance benchmarking, strategic information systems. Strategy evaluation tools: Strategic audit, feedback mechanisms. Corporate governance and ethical considerations in strategy.

**UNIT – V**

**Global Issues in Strategic Management:** Challenges and opportunities in international business strategy. Advantages & disadvantages of global operations. International taxation and regulatory frameworks. Role of global institutions in strategic decision-making.

**Textbooks:**

1. Fred R. David & Forest R. David, Strategic Management: A Competitive Advantage Approach Pearson (2023), 18th Edition, ISBN:9789361590955
2. Arthur A. Thompson et al., Crafting and Executing Strategy (2021), McGraw Hill, 22nd Edition, ISBN: 978-9354600043

**Reference Books:**

1. Azhar Kazmi, Strategic Management and Business Policy (2021) McGraw Hill, 4th Edition, ISBN: 978-9339221836
2. Lawrence R. Jauch & William F. Glueck, Business Policy and Strategic Management (2004) McGraw Hill, 5th Edition, ISBN: 978-0070323476

**Web Links:**

1. <http://tjsec.digimat.in/nptel/courses/video/110108047/L21.html>
2. <https://archive.nptel.ac.in/courses/110/108/110108047/>

**Relevant cases have to be discussed in each unit and in examination case study is compulsory from any unit.**

## LOGISTICS AND SUPPLY CHAIN MANAGEMENT

	<b>L</b>	<b>T</b>	<b>P</b>	<b>C</b>
<b>Course Code: 2507BA12</b>	<b>2</b>		<b>1</b>	<b>3</b>

### Course Outcomes:

**At the end of the Course, Student will be able to:**

- CO1:** Explain the concepts of logistics and supply chain management
- CO2:** Explore the characteristics of different modes of transportation and their roles in the supply chain.
- CO3:** Identify the benefits and constraints of containerization.
- CO4:** Familiarize with essentials and types of packing and packaging.
- CO5:** Summarize the concepts of import and export logistics

### Mapping of Course Outcomes with Program Outcomes:

COs / POs	PO1	PO2	PO3	PO4	PO5	PO6	PO7	PO8	PO9	PO10	PO11
<b>CO1</b>	3	3	3	3	3	3	3	3	3	3	3
<b>CO2</b>	3	3	3	3	3	3	3	3	3	3	3
<b>CO3</b>	2	2	2	1	1	1	1	1	2	1	1
<b>CO4</b>	2	2	2	1	1	1	1	1	2	1	1
<b>CO5</b>	2	2	2	2	1	1	2	1	2	2	2

### Mapping of Course Outcomes with Program Specific Outcomes:

CO / PSO	PSO1	PSO2	PSO3
CO1	3	2	2
CO2	3	2	2
CO3	2	2	2
CO4	2	2	2
CO5	3	2	3

### UNIT – I

**Logistics Management and Supply Chain Management** - Definition, evolution, and importance of logistics and supply chain management. Key drivers and logistics relationships in supply chain operations.

### UNIT – II

**Basics of Transportation**- Transportation principles and functions. Multimodal transport: characteristics and comparisons of different modes (air, ocean, road, and rail). International shipping and types of ships.

### UNIT – III

**Containerization:** Concept, classification, and advantages of containerization. Inland Container Depots (ICDs): roles, functions, and export clearance. Role of CONCOR and Container Freight Stations (CFS).

#### **UNIT – IV**

**Packing and Packaging:** Functions and essentials of packing and packaging for storage and transportation. Types of packaging (primary, secondary, tertiary). Modern packaging technologies: barcodes, electronic data interchange (EDI), and universal product codes.

#### **UNIT – V**

**Special Aspects of Export Logistics:** Export logistics: picking, packing, customs clearance, documentation, and shipment processes. Import logistics: bonded warehousing, valuation, and customs formalities.

#### **Textbooks:**

1. Martin Christopher, Logistics and Supply Chain Management (2022) Pearson, 6th Edition, ISBN: 9781292416182
2. Sunil Chopra & Peter Meindl, Supply Chain Management: Strategy, Planning, and Operation (2022) Pearson, 7th Edition, ISBN: 978-9353065966

#### **Reference Books:**

1. S.K. Bhattacharyya, Logistics Management Pearson (2020), 1st Edition, ISBN: 9788121928854
2. Michael H. Hugos, Essentials of Supply Chain Management (2018) Wiley, 4<sup>th</sup> Edition, ISBN: 9781119461104

#### **Web Links**

1. <https://archive.nptel.ac.in/courses/110/105/110105141/>
2. <https://www.youtube.com/watch?v=Nrl0CtS1mY>

**Relevant cases have to be discussed in each unit and in examination case study is compulsory from any unit.**

## INTELLECTUAL PROPERTY RIGHTS

<b>L</b>	<b>T</b>	<b>P</b>	<b>C</b>
<b>2</b>		<b>1</b>	<b>3</b>

**Course Code: 2507BA27**

### Course Outcomes:

**At the end of the Course, Student will be able to:**

- CO1:** Compare different IP laws and need for protecting
- CO2:** Explain different theories on the concept of property
- CO3:** Identify various functions of WIPO
- CO4:** Analyze the IP laws in India
- CO5:** Differentiate various forms of IPR

### Mapping of Course Outcomes with Program Outcomes:

COs / POs	PO1	PO2	PO3	PO4	PO5	PO6	PO7	PO8	PO9	PO10	PO11
<b>CO1</b>	2	2	1	3	2	2	1	1	2	2	2
<b>CO2</b>	2	2	1	2	1	1	1	1	1	1	1
<b>CO3</b>	2	2	2	2	2	2	1	2	1	1	1
<b>CO4</b>	2	2	1	3	3	2	2	2	2	2	2
<b>CO5</b>	2	2	1	3	2	2	1	1	1	1	2

### Mapping of Course Outcomes with Program Specific Outcomes:

CO / PSO	PSO1	PSO2	PSO3
<b>CO1</b>	2	3	2
<b>CO2</b>	2	2	1
<b>CO3</b>	2	2	1
<b>CO4</b>	3	2	2
<b>CO5</b>	3	3	2

### UNIT – I

**Introduction:** Origin and Development of IPR – Historical and theoretical basis for protection of IPR – Analyzing and understanding the Interpretation of IP laws – Need for Protecting IP

### UNIT – II

**Concept of Property:** Theories on concept of property – Nature – Public Vs. Private – Tangible Vs. Intangible – Industrial Vs. Intellectual

### UNIT – III

**International IP Regime:** World Intellectual Property Organization (WIPO) – Functions of WIPO – Membership – GATT Agreement – Major Conventions on IP – Berne Convention – Paris Convention – TRIPS agreement.

### UNIT – IV

**Indian IP Regime:** Overview of IP laws in India – Major IP Laws in India – International treaties signed by India. IPR and Constitution of India.

**UNIT – V**

**Forms of IPR:** Forms of IPR – Copyright – Trademark – Patents – Industrial Designs – Trade Secrets – Geographical Indications - Application of different forms of IPR.

**Textbooks:**

1. Prabuddha Ganguli, Intellectual Property Rights: Unleashing the Knowledge Economy (2022), McGraw Hill, 2nd Edition, ISBN: 978-0070077171
2. Deborah E. Bouchoux, Intellectual Property (2016), Cengage, 5th Edition, ISBN: 978- 1305948464

**Reference Books:**

1. B.L. Wadehra, Law Relating to Intellectual Property (2021), LexisNexis, 5th Edition, ISBN: 9789350350300
2. Neeraj Pandey &Khusdeep Dharni, Intellectual Property Rights (2014), PHI Learning, 1st Edition, ISBN: 9788120349896

**Web Links:**

- 1 [https://onlinecourses.nptel.ac.in/noc22\\_hs59/preview](https://onlinecourses.nptel.ac.in/noc22_hs59/preview)
- 2 <https://archive.nptel.ac.in/courses/110/105/110105139/>

**Relevant cases have to be discussed in each unit and in examination case study is compulsory from any unit.**

## PROJECT MANAGEMENT

**Course Code: 2507BA15**

<b>L</b>	<b>T</b>	<b>P</b>	<b>C</b>
<b>2</b>		<b>1</b>	<b>3</b>

### Course Outcomes:

**At the end of the Course, Student will be able to:**

**CO1:** Explain the basic concepts of project Management

**CO2:** Estimate project planning and risk.

**CO3:** Interpret project financing through techniques

**CO4:** Analyze the concept of Project controlling

**CO5:** Summarize stress management, conflict management and team building

### Mapping of Course Outcomes with Program Outcomes:

COs / POs	PO1	PO2	PO3	PO4	PO5	PO6	PO7	PO8	PO9	PO10	PO11
<b>CO1</b>	3	2	1	2	2	1	1	2	2	2	1
<b>CO2</b>	3	3	2	1	2	1	1	1	2	2	1
<b>CO3</b>	2	3	2	1	2	1	1	1	2	2	2
<b>CO4</b>	3	3	2	1	3	1	1	1	1	3	2
<b>CO5</b>	2	2	2	2	2	2	3	3	2	2	2

### Mapping of Course Outcomes with Program Specific Outcomes:

CO / PSO	PSO1	PSO2	PSO3
<b>CO1</b>	3	2	1
<b>CO2</b>	3	3	2
<b>CO3</b>	3	3	2
<b>CO4</b>	3	2	2
<b>CO5</b>	2	2	2

### UNIT – I

**Introduction to Project Management:** Project Characteristics – Project Life Cycle – Project Identification, Formulation and Implementation – Project Management in Different Sectors, Systems Approach to Project Management

### UNIT – II

**Project Appraisal:** Project Planning – Steps in Project Planning – Scheduling – Project Appraisal – Feasibility Study – Technical, Commercial, Economic, Financial, Management, Social, Cost Benefit Analysis – Project Risk Analysis

### UNIT – III

**Project Finance:** Project Cost Estimation, Project Financing – Investment Criteria, Project Evaluation Techniques – Cash Flows Estimation for New and Replacement Projects – Cost of Capital, Risk Analysis.

### UNIT – IV

**Project Control:** Network Diagrams, Network Analysis, Critical Path, Quality Management, Project Execution, Monitoring and Control, Agile Project Management, Scrum, Lean Production.

## **UNIT – V**

**Organizational Behavior and Project Management:** Structure & Integration, Project Manager & Team Role, Stakeholder Engagement, Leadership, Conflict & Stress Management in Projects.

### **Textbooks:**

1. Erik W. Larson & Clifford F. Gray, Project Management: The Managerial Process McGraw Hill (2022), 8th Edition, ISBN: 978-9354602078
2. A Guide to the Project Management Body of Knowledge (PMBOK Guide) (2021)– Project Management Institute, 7th Edition, ISBN: 978-1628256659

### **Reference Books:**

1. K. Nagarajan, Project Management (2020) New Age International, 9th Edition ISBN: 9789360748531
2. Harold Kerzner, Project Management: A Systems Approach (2017) Wiley, 12th Edition 2017 ISBN: 9781119165354

### **Web Links:**

1. [https://onlinecourses.nptel.ac.in/noc23\\_mg124/preview](https://onlinecourses.nptel.ac.in/noc23_mg124/preview)
2. [https://onlinecourses.nptel.ac.in/noc24\\_mg01/preview](https://onlinecourses.nptel.ac.in/noc24_mg01/preview)

**Relevant cases have to be discussed in each unit and in examination case study is compulsory from any unit.**

## BUSINESS TAXATION

	<b>L</b>	<b>T</b>	<b>P</b>	<b>C</b>
<b>Course Code: 2507BA02</b>	<b>2</b>	<b>1</b>		<b>3</b>

### Course Outcomes:

**At the end of the Course, Student will be able to:**

- CO1:** Explain the concept, structure, and components of GST within the Indian tax framework including registration processes and related constitutional provisions.
- CO2:** Describe the scope of supply, levy, composition scheme, input tax credit, and tax payment processes under GST.
- CO3:** Apply the procedures for filing GST returns, conducting audits, and handling assessments using Tally ERP and the GST portal.
- CO4:** Apply practical skills to configure, record, and file GST transactions and returns using accounting software like Tally ERP.
- CO5:** Analyze the provisions of customs law, types of duties, and procedures related to import/export, valuation, and duty drawbacks under the 2017 customs rules.

### Mapping of Course Outcomes with Program Outcomes:

COs / POs	PO1	PO2	PO3	PO4	PO5	PO6	PO7	PO8	PO9	PO10	PO11
<b>CO1</b>	3	2	1	2	2	3	2	1	2	2	2
<b>CO2</b>	2	3	2	1	2	2	2	2	1	2	1
<b>CO3</b>	2	3	2	1	2	3	1	1	2	2	2
<b>CO4</b>	3	3	3	1	2	2	2	2	2	1	2
<b>CO5</b>	3	2	2	2	2	2	2	1	2	2	2

### Mapping of Course Outcomes with Program Specific Outcomes:

CO / PSO	PSO1	PSO2	PSO3
<b>CO1</b>	3	2	1
<b>CO2</b>	2	2	2
<b>CO3</b>	2	2	2
<b>CO4</b>	3	3	2
<b>CO5</b>	3	2	2

### UNIT - I

**Introduction to GST and Tax Framework:** Overview of GST, need and objectives, Constitution (101st Amendment) Act 2016, structure of Indian taxation – direct vs. indirect taxes, GST Council, tax rates, dual model of GST, CGST, SGST, UTGST, IGST, GSTIN. GSTIN, process of registration and types – compulsory, exemption, cancellation, revocation.

### UNIT - II

**Supply, Levy and Input Tax Credit:** Meaning and scope of supply – composite and mixed supplies. Levy and collection of GST, composition scheme, time and value of supply. Input Tax Credit (ITC) – eligibility, distribution, documentation (invoices, credit/debit notes, vouchers). Payment of tax – ledgers, challans, timelines, interest, set-off and refund process.

### **UNIT - III**

**GST Returns and Audit:** Types of GST returns – GSTR-1 to GSTR-11. Audit under Sections 65 & 66, departmental audits, audit procedure, findings, and response. Assessment, demand and recovery rules. Practical work on GST registration, return filing, and tax payment using Tally ERP and GST portal.

### **UNIT - IV**

**Practical Applications of GST:** Hands-on training in GST setup using accounting software (Tally ERP). Defining GST rates at master and transaction levels, creating GST ledgers, accounting GST transactions, generating and exporting GSTRs, and filing them online.

### **UNIT - V**

**Basics of Customs Duty:** Introduction to customs law, territorial waters, types of duties – basic, protective, countervailing, safeguard, anti-dumping. Concepts like baggage rules, warehousing, export procedure, deemed exports, duty drawback, and valuation of import/export goods under 2017 customs rules.

#### **Textbooks:**

1. Akhileshwar Pathak & Savan Godiawala, Business Taxation McGraw-Hill Education India, Print ISBN: 978-1259098024, eText ISBN: 978-1259098017.
2. CA Raj K. Agrawal, Handbook on Income Tax (A.Y. 2025–2026) Bharat Law House Pvt. Ltd. ISBN: 978-93-4808-017-2

#### **Reference Books:**

1. Dr. Girish Ahuja & Dr. Ravi Gupta, Systematic Approach to Income Tax (Golden Jubilee Edition 2025) Commercial Law Publishers, ISBN: 978-93-5603-720-5.
2. A.N. Aiyar's Indian Tax Laws, 2025, Company Law Institute, ISBN: 978-93-5569-443-0.

#### **Web Links:**

1. <https://www.youtube.com/watch?v=swrzarYcMvY>
2. [https://www.youtube.com/watch?v=QUI\\_OevD3yw](https://www.youtube.com/watch?v=QUI_OevD3yw)

**Relevant cases have to be discussed in each unit and in examination case study is compulsory from any unit.**

**PROGRAM ELECTIVE COURSES  
 INTRODUCTION TO BUSINESS ANALYTICS**

	<b>L</b>	<b>T</b>	<b>P</b>	<b>C</b>
<b>Course Code: 2507BA11</b>	<b>2</b>		<b>1</b>	<b>3</b>

**Course Outcomes:**

**At the end of the Course, Student will be able to:**

- CO1:** Explain the historical overview and importance of business analytics in practice.
- CO2:** Organize various sources of data and data visualization.
- CO3:** Analyze data mining and multi-dimensional data analysis
- CO4:** Apply the concepts of machine learning.
- CO5:** Apply the concepts of analytics in business areas such as retail, marketing, finance, health care and supply chain.

**Mapping of Course Outcomes with Program Outcomes:**

CO / PO	PO1	PO2	PO3	PO4	PO5	PO6	PO7	PO8	PO9	PO10	PO11
<b>CO1</b>	2	2	3	2	3	2	2	2	3	3	2
<b>CO2</b>	3	3	2	2	3	3	2	2	3	3	2
<b>CO3</b>	2	3	3	3	2	3	2	2	3	2	2
<b>CO4</b>	2	2	2	3	2	3	2	2	2	2	2
<b>CO5</b>	3	3	3	2	3	3	3	2	3	3	2

**Mapping of Course Outcomes with Program Specific Outcomes:**

CO/PSO	PSO1	PSO2	PSO3
<b>CO1</b>	1	2	1
<b>CO2</b>	1	2	1
<b>CO3</b>	1	2	1
<b>CO4</b>	1	3	1
<b>CO5</b>	2	3	1

**UNIT – I**

**Introduction:** What is business analytics? Historical Overview of data analysis, Data Scientist vs. Data Engineer vs. Business Analyst, Career in Business Analytics, what is data science, Why Data Science, Applications for data science, Data Scientists Roles and Responsibility

**UNIT – II**

**Data:** Data Collection, Data Management, Big Data Management, Organization/sources of data, Importance of data quality, Dealing with missing or incomplete data, Data Visualization, Data Classification Data Science Project Life Cycle: Business Requirement, Data Acquisition, Data Preparation, Hypothesis and Modeling, Evaluation and Interpretation, Deployment, Operations, Optimization.

**UNIT – III**

**Introduction to Data Mining:** The origins of Data Mining, Data Mining Tasks, OLAP and Multidimensional data analysis, Basic concept of Association Analysis and Cluster Analysis.

#### **UNIT – IV**

**Introduction to Machine Learning:** History and Evolution, AI Evolution, Statistics Vs Data Mining Vs, Data Analytics Vs, Data Science, Supervised Learning, Unsupervised Learning, Reinforcement Learning, Frameworks for building Machine Learning Systems.

#### **UNIT – V**

**Application of Business Analytics:** Retail Analytics, Marketing Analytics, Financial Analytics, Healthcare Analytics, Supply Chain Analytics.

#### **Textbooks:**

1. Richard I. Levin & David S. Rubin, Statistics for Management (2012), Pearson Education, 7th Edition, ISBN: 978-1292039930
2. S.P. Gupta,, Business Statistics (2021), Sultan Chand & Sons, Revised Edition ISBN: 978-9351611066

#### **Reference Books:**

1. Paul Newbold, William Carlson, Betty Thorne, Statistics for Business and Economics (2020), Pearson, 10th Edition ISBN: 978-1292436906
2. Goon, Gupta, Dasgupta, Fundamentals of Statistics (2014), World Press, 3rd Edition, ISBN: 978-8187567806

#### **Web Links:**

- 1 <https://nptel.ac.in/courses/110106050>
- 2 <https://archive.nptel.ac.in/courses/110/105/110105089/>

**Relevant cases have to be discussed in each unit and in examination case study is compulsory from any unit.**

## DATA ANALYSIS WITH PYTHON

	<b>L</b>	<b>T</b>	<b>P</b>	<b>C</b>
<b>Course Code: 2507BA05</b>	<b>2</b>		<b>1</b>	<b>3</b>

### Course Outcomes:

**At the end of the Course, Student will be able to:**

**CO1:** Understand and use basic Python concepts to write simple programs for business needs.

**CO2:** Work with data using the Pandas library to organize and analyze datasets.

**CO3:** Create basic charts using Matplotlib and Seaborn to visualize business data.

**CO4:** Apply simple statistical methods to analyze and interpret business data.

**CO5:** Conduct a basic mini project using Python to solve a real-world business problem.

### Mapping of Course Outcomes with Program Outcomes:

CO / PO	PO1	PO2	PO3	PO4	PO5	PO6	PO7	PO8	PO9	PO10	PO11
<b>CO1</b>	3	2	2	2	1	1	2	2	3	2	1
<b>CO2</b>	3	3	2	2	1	1	2	2	3	2	1
<b>CO3</b>	2	2	2	3	1	1	2	2	3	2	1
<b>CO4</b>	2	3	3	2	2	1	2	2	3	2	2
<b>CO5</b>	3	3	3	3	2	2	3	3	3	3	2

### Mapping of Course Outcomes with Program Specific Outcomes:

CO / PSO	PSO1	PSO2	PSO3
<b>CO1</b>	3	2	2
<b>CO2</b>	3	3	2
<b>CO3</b>	3	2	2
<b>CO4</b>	3	3	3
<b>CO5</b>	3	3	3

### UNIT – I

**Introduction to Python Programming:** Concept, Importance of Python in business, installing Python and Jupyter Notebook, basic syntax, variables, data types, lists, tuples, dictionaries, sets, conditional statements, loops, functions, simple business examples like profit calculation and pricing models.

### UNIT – II

**Working with Data using Pandas:** Introduction to Pandas, Series and Data Frames, reading data from Excel and CSV files, handling missing data, filtering and selecting data, grouping and summarizing data, merging datasets, simple business examples like sales reports, customer segments, and employee records.

### UNIT – III

**Data Visualization Basics:** Introduction to Matplotlib and Seaborn, line graphs, bar charts, pie charts, histograms, scatter plots, customizing plots with titles, labels, and legends, business examples like customer trends, product sales, and financial overviews.

### UNIT – IV

**Basic Statistical Analysis:** Mean, median, mode, standard deviation, correlation and trends, introduction to hypothesis testing (concept only), overview of simple linear regression, use cases like business performance comparison and decision support.

## **UNIT – V**

**Mini Project / Practical Task** Dataset selection, data cleaning and preparation, data visualization, basic statistical interpretation, report writing, presentation of findings with a business conclusion.

### **Textbooks:**

1. Jonathan Rioux, Data Analysis with Python and PySpark(2022), Manning Publications, 1st Edition, ISBN: 978-1617297205
2. Avinash Navlani, Armando Fandango & Ivan Idris, Python Data Analysis (2021), Packt Publishing, 3rd Edition, ISBN: 978-1789955248

### **Reference Books:**

1. Walter R. Paczkowski, Business Data Analytics with Python (2022) O'Reilly Media, 1st Edition, ISBN: 0636920672197
2. Wes McKinney, Python for Data Analysis (2022), O'Reilly Media, 3rd Edition ISBN: 978- 1098104030

### **Web Links:**

1. [https://onlinecourses.nptel.ac.in/noc21\\_cs45/preview](https://onlinecourses.nptel.ac.in/noc21_cs45/preview)
2. <https://nptel.ac.in/courses/106107220>

**Relevant cases have to be discussed in each unit and in examination case study is compulsory from any unit.**

## MARKETING ANALYTICS

<b>Course Code: 2507BA13</b>	<b>L</b>	<b>T</b>	<b>P</b>	<b>C</b>
	<b>2</b>		<b>1</b>	<b>3</b>

### Course Outcomes:

**At the end of the Course, Student will be able to:**

- CO1:** Explain the Concepts of Marketing Analytics and their relevance in business.
- CO2:** Make use of MS Excel to deal with Marketing Data at basic level.
- CO3:** Appreciate Customer's journey through Product Selection Process and Customer Lifetime Value.
- CO4:** Conduct Analysis in Determining the Pricing Strategies
- CO5:** Analyze the Process of Optimizing Clusters and Measure the Effectiveness of Promotion

### Mapping of Course Outcomes with Program Outcomes:

CO / PO	PO1	PO2	PO3	PO4	PO5	PO6	PO7	PO8	PO9	PO10	PO11
<b>CO1</b>	3	2	2	2	2	2	2	1	2	2	2
<b>CO2</b>	3	3	2	2	2	2	3	1	3	2	2
<b>CO3</b>	2	3	2	3	2	2	3	2	2	3	2
<b>CO4</b>	3	3	2	3	2	2	3	2	3	3	2
<b>CO5</b>	2	3	2	3	2	2	3	2	3	3	3

### Mapping of Course Outcomes with Program Specific Outcomes:

CO / PSO	PSO1	PSO2	PSO3
<b>CO1</b>	3	2	2
<b>CO2</b>	2	3	2
<b>CO3</b>	2	3	3
<b>CO4</b>	3	3	2
<b>CO5</b>	2	3	3

### UNIT – I

**Introduction to Marketing Analytics:** Definition, Need and Scope, Comparison with Marketing Research, Analytics Levels (Descriptive, Diagnostic, Predictive, Prescriptive), Applications in Marketing, Role in Business Intelligence.

**Excel in Marketing Analytics:** Using Excel as an Analytics Tool, Data Organization, Data Summarization, Pivot Table Creation.

### UNIT – II

**Summarizing Marketing Data:** Revenue Summary, Data Slicing (Pareto, Filters, Slicers), Demographic Analysis, Crosstabs, GETPIVOTDATA, Data Labels, Data Tables.

### UNIT – III

**Customer Analytics:** Journey Mapping, Experience Metrics, Customer Persona, Conjoint Analysis, Customer Lifetime Value (CLV), CLV Calculation, Sensitivity Analysis, Retention Estimation.

### UNIT – IV

**Pricing Analytics:** Pricing Goals, Price Elasticity, Demand Curve Estimation, Price Optimization with Solver, Multi-product Pricing, Price Bundling, Mixed Bundling, Optimal Bundle Pricing, Price Skimming.

#### **UNIT – V**

**Segmentation & Promotion Analytics: Segmentation Analytics:** Cluster Analysis, Location Clustering, Solver for Optimal Clusters, Conjoint Analysis, Decision Trees for Segmentation. **Promotion Analytics:** Promotion Types, Discounting Types, Advertising Effectiveness (Adstock Model), Media Selection (Linear Model, Quantity Discounts, Monte Carlo Simulation), Pay per Click Advertising.

#### **Textbooks:**

1. Stephan Sorger, Marketing Analytics: Strategic Models and Metrics (2014), Create Space Independent, 1st Edition, ISBN: 9781481900300
2. Wayne L. Winston, Wiley, Marketing Analytics: Data-Driven Techniques with MS Excel, 1st Edition, ISBN: 978-1118417300

#### **Reference Books:**

1. Mike Grigsby, Marketing Analytics: A Practical Guide (2018), Kogan Page, 2nd Edition, ISBN: 9780749482169
2. Naresh K. Malhotra, Marketing Research (2020) Pearson, 7th Edition, ISBN: 978- 9353433291

#### **Web Links:**

1. [https://onlinecourses.nptel.ac.in/noc20\\_mg30/preview](https://onlinecourses.nptel.ac.in/noc20_mg30/preview)
2. <https://archive.nptel.ac.in/courses/110/105/110105142/>

**Relevant cases have to be discussed in each unit and in examination case study is compulsory from any unit.**

## FINANCIAL ANALYTICS

	<b>L</b>	<b>T</b>	<b>P</b>	<b>C</b>
<b>Course Code: 2507BA09</b>	<b>2</b>		<b>1</b>	<b>3</b>

### Course Outcomes:

**At the end of the Course, Student will be able to:**

- CO1:** Examine financial statements to interpret organizational financial health.
- CO2:** Apply time value of money and risk-return measures to make financial decisions.
- CO3:** Analyze investment opportunities using capital budgeting techniques
- CO4:** Assess equity valuations and perform industry, economic, and technical analysis.
- CO5:** Interpret bond valuation and immunization strategies to manage fixed-income portfolios effectively.

### Mapping of Course Outcomes with Program Outcomes:

CO / PO	PO1	PO2	PO3	PO4	PO5	PO6	PO7	PO8	PO9	PO10	PO11
<b>CO1</b>	3	3	2	2	2	2	2	2	2	2	2
<b>CO2</b>	3	3	3	2	2	2	2	2	3	2	2
<b>CO3</b>	3	3	3	2	2	2	2	2	3	3	2
<b>CO4</b>	3	3	3	2	2	2	2	2	3	3	2
<b>CO5</b>	3	3	3	2	2	2	2	2	3	3	2

### Mapping of Course Outcomes with Program Specific Outcomes:

CO / PSO	PSO1	PSO2	PSO3
<b>CO1</b>	3	2	2
<b>CO2</b>	3	2	2
<b>CO3</b>	3	3	3
<b>CO4</b>	3	3	3
<b>CO5</b>	3	3	3

### UNIT – I

**Techniques of Financial Statement:** Horizontal, Vertical Analysis, Trend Analysis, Ratio Analysis, Liquidity, Profitability, Solvency and Turnover Ratio, Valuation of Ratios, Statement of Cash Flow, Classification of Cash Flow, Computing Net Cash Flow: Operating, Investing and Financing Activities. Reporting and Interpretation using Spreadsheet.

### UNIT – II

**Time Value of Money:** Future Value: Simple, Compound Interest and Annuity, Present Value: Discounted, Annuity, Equated Loan Amortization, Perpetuity using Spreadsheets. **Risk and Return:** Holding Period Returns, Arithmetic Mean vs Geometric Mean, Risk: Standard Deviation, Coefficient of Variation, Beta, Covariance of Stock.

### UNIT – III

**Capital Budgeting Techniques:** Payback Period, Accounting Rate of Return, Net Present Value, Internal Rate of Return, Profitability Index, Decision Tree, Cash Flow in Capital Budgeting, Cost of Capital, Advance Capital Budgeting Techniques, Adjusted Present Value Approach, Competing Project Risk using Spreadsheets.

#### **UNIT – IV**

**Equity Valuation:** Calculation of Portfolio Mean and Variance, Capital Asset Pricing Model (CAPM), Variance: Covariance Matrix, Estimating Beta and Security Market Line. Industry Analysis, Economic Analysis and Technical Analysis in Stock, Real Option in Capital Budgeting.

#### **UNIT – V**

**Bond Valuation:** Duration, Duration of Bond with Uneven Payments, Immunization Strategies, Modelling the Term Structure, Calculating Expecting Bond Return in a Single and Multi-period Framework, Semi-annual Transition Matrix, Computation of Bond Beta.

#### **Textbooks:**

1. Mark J. Bennett & Dirk L. Hugen, Financial Analytics with R (2016), Cambridge University Press, 1st Edition, ISBN: 978-1107150751
2. Simon Benninga, Financial Modeling (2014) MIT Press, 4th Edition, ISBN: 9780262027281

#### **Reference Books:**

1. K.R. Subramanyam, Financial Statement Analysis (2014), McGraw Hill, 11th Edition ISBN: 9780078110962
2. Kenneth L. Grant, Quantitative Financial Analytics (2015), Wiley, 1st Edition, ISBN: 978-1-118-62988-8

#### **Web Links:**

1. <https://www.coursera.org/learn/applying-data-analytics-business-in-finance>
2. <https://www.udemy.com/course/financial-analytics-excel-tableau/>

**Relevant cases have to be discussed in each unit and in examination case study is compulsory from any unit.**

## HR ANALYTICS

	<b>L</b>	<b>T</b>	<b>P</b>	<b>C</b>
<b>Course Code: 2507BA10</b>	<b>2</b>		<b>1</b>	<b>3</b>

**Course Outcomes:**

**At the end of the Course, Student will be able to:**

- CO1:** Explain the evolution and scope of HR analytics and apply HR metrics for efficient HR operations and performance measurement.
- CO2:** Demonstrate the use of descriptive analytics and tools like dashboards and pivot tables for HR data visualization and analysis.
- CO3:** Apply statistical tools such as correlation, regression, t-tests, and ANOVA in HR analytics contexts for data interpretation.
- CO4:** Analyze HR problems using classification techniques like logistic regression and interpret analytical results for strategic decision-making.
- CO5:** Evaluate and apply advanced HR analytics techniques (decision trees, clustering) to address key HR areas such as attrition, absenteeism, and training effectiveness.

**Mapping of Course Outcomes with Program Outcomes:**

CO / PO	PO1	PO2	PO3	PO4	PO5	PO6	PO7	PO8	PO9	PO10	PO11
<b>CO1</b>	3	2	2	3	2	1	2	2	2	2	1
<b>CO2</b>	3	3	3	2	3	2	3	2	2	3	2
<b>CO3</b>	3	3	3	3	3	3	2	2	3	3	3
<b>CO4</b>	3	3	3	3	3	3	2	3	3	3	3
<b>CO5</b>	3	3	3	3	3	2	2	3	3	3	2

**Mapping of Course Outcomes with Program Specific Outcomes:**

CO / PSO	PSO1	PSO2	PSO3
<b>CO1</b>	3	2	2
<b>CO2</b>	3	3	3
<b>CO3</b>	2	3	3
<b>CO4</b>	2	3	3
<b>CO5</b>	2	3	3

**UNIT- I:**

**Introduction to HR Analytics and Metrics:** Evolution and importance of HR analytics, Role of HR analytics in strategic decision-making, HR metrics: HR operations, recruitment, training and development, Use of metrics for monitoring and correction.

**UNIT-II:**

**Descriptive Analytics and Dashboards:** Descriptive analytics in HR, Creation and usage of HR dashboards using software, Slicing and dicing HR data using pivot tables, Visual representation of HR data.

**UNIT- III:**

**Statistical Tools for HR Analytics:** Correlation and regression analysis, T-tests: ne-sample, independent, paired, One-way and two- way ANOVA, Interpretation of statistical outputs.

**UNIT-IV:**

**Predictive HR Analytics:** Application of logistic regression for classification, Predictive modeling for HR decisions, Evaluation of results, Implementation in workforce planning and employee retention.

**UNIT-V:**

**Advanced HR Analytics Applications:** Analytics applied to absenteeism, attrition, training and development, Job classification techniques, Clustering algorithms, Decision tree analysis in HR.

**Textbooks:**

1. Dipak Kumar Bhattacharyya, HR Analytics: Understanding Theories and Applications (2017), Sage Publications, 1st Edition, ISBN: 9789386062710
2. Jac Fitz-enz, The New HR Analytics (2010), AMACOM, 1st Edition ISBN: 9780814416433

**Reference Books:**

1. Ben Waber, People Analytics (2013), FT Press, 1st Edition ISBN: 978-0133158311
2. Predictive HR Analytics (2019), Martin Edwards & Kirsten Edwards, Kogan Page, 2nd Edition, ISBN: 978-0749484446

**Web Links:**

1. [HR Analytics - Course](#)
2. [Human Resources Analytics | Coursera](#)

**Relevant cases have to be discussed in each unit and in examination case study is compulsory from any unit**

## PREDICTIVE ANALYTICS

**Course Code: 2507BA14**

<b>L</b>	<b>T</b>	<b>P</b>	<b>C</b>
<b>2</b>		<b>1</b>	<b>3</b>

**Course Outcomes:**

**At the end of the Course, Student will be able to:**

**CO1:** Explain descriptive, predictive, and prescriptive analytics, and assess their applications

**CO2:** Examine qualitative forecasting methods to make informed predictions and distinguish them.

**CO3:** Implement linear regression techniques using Excel to analyze and predict relationships between variables.

**CO4:** Apply moving averages for forecasting and evaluate their effectiveness using Excel.

**CO5:** Simplify and structure various types of documents using various tools.

**Mapping of Course Outcomes with Program Outcomes:**

CO / PO	PO1	PO2	PO3	PO4	PO5	PO6	PO7	PO8	PO9	PO10	PO11
<b>CO1</b>	3	3	2	1	3	1	2	2	3	2	2
<b>CO2</b>	3	3	2	2	2	2	2	1	2	3	2
<b>CO3</b>	2	3	2	1	2	3	3	2	3	2	1
<b>CO4</b>	2	3	2	1	2	2	3	3	2	2	1
<b>CO5</b>	1	2	3	1	3	2	2	2	1	1	2

**Mapping of Course Outcomes with Program Specific Outcomes:**

CO / PSO	PSO1	PSO2	PSO3
<b>CO1</b>	3	2	2
<b>CO2</b>	3	3	2
<b>CO3</b>	3	2	3
<b>CO4</b>	3	3	3
<b>CO5</b>	2	2	3

**UNIT – I**

**Introduction to Predictive Analytics:** Definition of Analytics advantage and limitation of analytics  
 Definition of predictive analytics –Introduction to Descriptive analytics, Predictive analytics, Prescriptive analytics (theory only) - Applications and limitation of predictive analytics.

**UNIT – II**

**Forecasting with Qualitative Methods:** Meaning of Qualitative forecasting – Methods of Qualitative forecasting – Criteria to select method of forecasting - Application areas of Qualitative methods - Differentiation between Qualitative and Quantitative forecasting methods.

**UNIT – III**

**Linear Regression:** Correlation and Regression - Charting the Relationship -Calculating Pearson's Correlation Coefficient- Simple Regression – Array - Entering Formulas- Multiple Regression – LINEST function with Multiple Predictors - Using Excel.

#### **UNIT – IV**

**Forecasting with Moving Averages:** About Moving Averages – Types of moving averages Signal and Noise- Lost Periods -Smoothing Versus Tracking - Criteria for Judging Moving Averages - Mean Absolute Deviation - Least Squares – Using Excel.

#### **UNIT – V**

**Working with Documents:** Defining purpose and scope documents, Understanding structure of documents – case studies, articles, white papers, technical reports, minutes of meeting Documentation formats and Styles. Document preparation tools – PowerPoint, Word, Excel.

#### **Textbooks:**

1. Lie, or Die – Eric Siegel, Predictive Analytics: The Power to Predict Who Will Click, Buy (2020), Wiley, Revised Edition, ISBN: 978-1119153658
2. Dean Abbott, Applied Predictive Analytics (2014), Wiley, 1st Edition, ISBN: 978- 1118727966

#### **Reference Books:**

1. Valentine Fontama et al., Predictive Analytics with Microsoft Azure (2017) ML Apress, 2nd Edition, ISBN: 978-1484212011
2. Galit Shmueli et al., Machine Learning for Business Analytics (2020), Wiley, 3rd Edition, ISBN: 978-1119829867

#### **Web Links:**

1. [https://onlinecourses.nptel.ac.in/noc23\\_ma46/preview](https://onlinecourses.nptel.ac.in/noc23_ma46/preview)
2. <https://www.coursera.org/learn/predictive-analytics>

**Relevant cases have to be discussed in each unit and in examination case study is compulsory from any unit.**

## BIG DATA ANALYTICS

**Course Code: 2507BA01**

<b>L</b>	<b>T</b>	<b>P</b>	<b>C</b>
<b>2</b>		<b>1</b>	<b>3</b>

### Course Outcomes:

**At the end of the Course, Student will be able to:**

- CO1:** Explain big data futures and classification of analytics
- CO2:** Develop knowledge on analytics flow for big data and big data stack
- CO3:** Analyze big data tool using Hadoop
- CO4:** Identify the security related aspects in big data
- CO5:** Discover various application areas of big data

### Mapping of Course Outcomes with Program Outcomes:

CO / PO	PO1	PO2	PO3	PO4	PO5	PO6	PO7	PO8	PO9	PO10	PO11
<b>CO1</b>	3	3	3	3	3	3	3	3	2	2	2
<b>CO2</b>	3	3	3	3	3	3	3	3	2	2	2
<b>CO3</b>	3	3	3	3	3	3	3	3	2	2	2
<b>CO4</b>	3	3	3	3	3	3	3	3	2	2	3
<b>CO5</b>	3	3	3	3	3	3	3	3	3	2	2

### Mapping of Course Outcomes with Program Specific Outcomes:

CO / PSO	PSO1	PSO2	PSO3
<b>CO1</b>	3	3	3
<b>CO2</b>	3	3	3
<b>CO3</b>	3	3	3
<b>CO4</b>	3	3	3
<b>CO5</b>	3	3	3

### UNIT-I

**Introduction to Big Data:** Overview of analytics (Descriptive, Diagnostic, Predictive, and Prescriptive). Introduction to Big Data and its characteristics (Volume, Velocity, Variety, Veracity, and Value).

### UNIT-II

**Analytics Flow and Big Data Stack:** Data collection, preparation, analysis types and modes, visualizations, and Big Data stack components like data sources, access connectors, storage, batch and real-time analytics, querying, and web frameworks.

### UNIT-III

**Big Data - Hadoop:** Overview of NoSQL, comparison with SQL, Hadoop vs. RDBMS, distributed computing challenges, Hadoop Distributed File System (HDFS), processing with Hadoop, managing resources with YARN, and interacting with the Hadoop ecosystem.

**UNIT-IV**

**Security in Big Data:** Security, compliance, auditing, protection strategies for Big Data, classifying data, safeguarding analytics, and addressing intellectual property challenges.

**UNIT-V**

**Big Data Applications:** Business applications of Big Data in sectors like Finance, Web, Healthcare, IoT, Environment, Logistics, Industry, and Retail.

**Textbooks:**

1. Rajkumar Buyya & Rodrigo N. Calheiros, Big Data: Principles and Paradigms (2022), Morgan Kaufmann, 2nd Edition, ISBN: 9780128053942
2. Seema Acharya & Subhashini Chellappan, Big Data Analytics (2019) Wiley India, 2nd Edition ISBN: 978-8126579518

**Reference Books:**

1. Viktor Mayer-Schönberger & Kenneth Cukier, Big Data: A Revolution That Will Transform How We Live, Work, and Think (2013), Houghton Mifflin, 1st Edition ISBN: 9780544002692
2. Data Science and Big Data Analytics (2015), EMC Education Services, Wiley, 1st Edition, ISBN: 9781118876138

**Web Links:**

1. [https://onlinecourses.swayam2.ac.in/arp19\\_ap60/preview](https://onlinecourses.swayam2.ac.in/arp19_ap60/preview)
2. <https://www.coursera.org/specializations/big-data>

**Relevant cases have to be discussed in each unit and in examination case study is compulsory from any unit.**

## WEB ANALYTICS

	<b>L</b>	<b>T</b>	<b>P</b>	<b>C</b>
<b>Course Code: 2507BA18</b>	<b>2</b>		<b>1</b>	<b>3</b>

### Course Outcomes:

**At the end of the Course, Student will be able to:**

- CO1:** Explain the importance of analytics in the context of social media and websites, emphasizing the role of data - driven decision – making.
- CO2:** Familiarize participants with fundamental metrics used in web analytics and social media analytics.
- CO3:** Identify the key performance indicators (KPIs) for social media and web analytics.
- CO4:** Show how to set up and track conversions on websites and social media platforms and understand the customer journey and optimize for conversion goals.
- CO5:** Analyze the concepts of social listening and monitoring and use tools to monitor brand mentions, track sentiment, and stay informed about industry trends.

### Mapping of Course Outcomes with Program Outcomes:

CO / PO	PO1	PO2	PO3	PO4	PO5	PO6	PO7	PO8	PO9	PO10	PO11
<b>CO1</b>	3	3	3	3	3	3	3	3	2	2	2
<b>CO2</b>	3	3	3	3	3	3	3	3	2	2	2
<b>CO3</b>	3	3	3	3	3	3	3	3	2	2	2
<b>CO4</b>	3	3	3	3	3	3	3	3	2	2	3
<b>CO5</b>	3	3	3	3	3	3	3	3	3	2	2

### Mapping of Course Outcomes with Program Specific Outcomes:

CO / PSO	PSO1	PSO2	PSO3
<b>CO1</b>	3	3	3
<b>CO2</b>	3	3	3
<b>CO3</b>	3	3	3
<b>CO4</b>	3	3	3
<b>CO5</b>	3	3	3

### UNIT – I

**Introduction to the Web:** Limitations of the current web, development of the semantic web, emergence of the social web, statistical properties of social networks, network analysis, key concepts in social network analysis, discussion networks, blogs, and online communities.

### UNIT – II

**Modeling and Visualization:** Visualizing online social networks, centrality, clustering, node-edge diagrams, matrix-based representations, node-link diagrams, hybrid representations, modeling social network data, random walks, Hadoop, MapReduce, ontological representation of relationships.

### UNIT – III

**Mining Communities:** Aggregating social network data, community detection, evaluating communities, methods for community detection, applications of community mining algorithms, node classification.

#### **UNIT – IV**

**Text and Opinion Mining:** Text mining, opinion extraction, sentiment classification, temporal sentiment analysis, irony detection, product review mining, sentiment tracking over time.

#### **UNIT – V**

**Tools for Social Network Analysis:** UCINET, PAJEK, ETDRAW, Stoc NET, Splus, R, NodeXL, SIENA, RSIENA, real-world social networks (e.g., Facebook, Twitter).

#### **Textbooks:**

1. Kevin Hartman, Digital Marketing Analytics (2020), Amazon Independent, 1st Edition, ISBN: 979- 8638634780
2. Avinash Kaushik, Web Analytics 2.0 (2009), Sybex/Wiley, 1st Edition, ISBN: 9780470529393

#### **Reference Books:**

1. Chuck Hemann & Ken Burbary, Digital Marketing Analytics (2018), Pearson, 2nd Edition, ISBN: 9780789759603
2. Brian Clifton, Advanced Web Metrics with Google Analytics (2012), Wiley, 3rd Edition, ISBN: 9781118168448

#### **Web Links:**

1. [https://onlinecourses.nptel.ac.in/noc22\\_mg68/preview](https://onlinecourses.nptel.ac.in/noc22_mg68/preview)
2. <https://www.coursera.org/professional-certificates/google-data-analytics>

**Relevant cases have to be discussed in each unit and in examination case study is compulsory from any unit.**

## DATA MINING AND MACHINE LEARNING

	<b>L</b>	<b>T</b>	<b>P</b>	<b>C</b>
<b>Course Code: 2507BA06</b>	<b>2</b>		<b>1</b>	<b>3</b>

### Course Outcomes:

#### At the end of the Course, Student will be able to:

- CO1:** Explore the kinds of data that can be mined, major issues in data mining, and the societal impact of data mining.
- CO2:** Determine reasons for data preprocessing, major tasks involved, and techniques for data cleaning, reduction, transformation, and discretization.
- CO3:** Analyze the machine learning concepts, types of algorithms, and specific supervised learning algorithms.
- CO4:** Illustrate the user-based and item-based similarity in recommender systems, calculate cosine similarity, and address challenges with similarity measures.
- CO5:** Summarize the decision trees, building classifiers using gini criteria and entropy criteria. Measure test accuracy, display decision trees, find optimal criteria,

### Mapping of Course Outcomes with Program Outcomes:

CO / PO	PO1	PO2	PO3	PO4	PO5	PO6	PO7	PO8	PO9	PO10	PO11
<b>CO1</b>	3	3	2	1	2	2	3	2	2	3	2
<b>CO2</b>	3	3	3	2	2	2	3	2	2	3	3
<b>CO3</b>	3	3	3	2	3	2	3	3	2	3	3
<b>CO4</b>	2	3	2	1	3	2	3	3	3	3	2
<b>CO5</b>	3	3	3	2	3	3	3	2	3	3	3

### Mapping of Course Outcomes with Program Specific Outcomes:

CO / PSO	PSO1	PSO2	PSO3
<b>CO1</b>	3	2	2
<b>CO2</b>	3	3	3
<b>CO3</b>	3	3	2
<b>CO4</b>	3	3	2
<b>CO5</b>	3	3	3

### UNIT – I

**Introduction to Data Mining:** Data Mining; Kinds of data that can be mined-Database Data, Data Warehouses, Transactional Data, Other Kinds of Data; Major Issues in Data Mining- Mining Methodology, User Interaction, Efficiency and Scalability, Diversity of Database Types, Data Mining and Society.

### UNIT – II

**Data Preprocessing:** An Overview-Reasons to process the data, Major Tasks in Data Preprocessing; Data Cleaning-Missing Values, Noisy Data, Data Cleaning as a Process; Data Reduction-Principal Component Analysis, Histograms, Clustering, Sampling, Data Cube Aggregation; Data Transformation and Data Discretization-Data Transformation by Normalization, Discretization by Binning, Discretization by Histogram Analysis.

### UNIT – III

**Machine Learning:** What is Machine Learning; Types of Machine Learning Algorithms- Supervised, Unsupervised and Reinforcement Learning. Supervised Learning-K Nearest Neighbors, Random Forest and Boosting.

#### **UNIT – IV**

**Recommender Systems Using Machine Learning:** User Based Similarity-Calculating Cosine Similarity Between Users, Filtering Similar Users, Challenges with User Based Similarity. Item Based Similarity-Calculating Cosine Similarity between Movies, Finding Most Similar Movies. Matrix Factorization.

#### **UNIT – V**

**Decision Tree Classification:** Introduction to Decision Tree; Building Decision Tree Classifier using Gini Criteria; Measuring Test Accuracy; Displaying the Tree; Building Decision Tree Classifier using Entropy Criteria. Finding Optimal Criteria; Maximum Depth of the Tree and Benefits and Disadvantages of Decision Tree Case Study: Applying Decision Tree Classification on German Credit Data.

#### **Textbooks:**

1. Jiawei Han, Micheline Kamber & Jian Pei, , Data Mining: Concepts and Techniques (2022), Morgan Kaufmann, 4th Edition, ISBN: 978-0128117606
2. Pang-Ning Tan, Michael Steinbach & Vipin Kumar, Introduction to Data Mining (2021), Pearson, 2nd Edition, 2021, ISBN: 9789354491047

#### **Reference Books:**

1. Tom M. Mitchell, Machine Learning (2017), McGraw Hill, 1st Edition, ISBN: 978- 1259096952
2. Galit Shmueli et al., Data Mining for Business Analytics (2019) Wiley, 4th Edition, ISBN: 978-1119549840

#### **Web Links:**

- 1 [https://onlinecourses.nptel.ac.in/noc21\\_cs06/preview](https://onlinecourses.nptel.ac.in/noc21_cs06/preview)
- 2 <https://www.coursera.org/specializations/machine-learning-introduction>

**Relevant cases have to be discussed in each unit and in examination case study is compulsory from any unit**

## DATA VISUALIZATION

**Course Code: 2507BA07**

<b>L</b>	<b>T</b>	<b>P</b>	<b>C</b>
<b>2</b>		<b>1</b>	<b>3</b>

### Course Outcomes:

**At the end of the Course, Student will be able to:**

- CO1:** Understand and apply the principles of effective data visualization in various business contexts.
- CO2:** Preprocess, clean, and prepare data for effective visualization.
- CO3:** Utilize basic visualization techniques to represent different data types and patterns.
- CO4:** Design interactive dashboards and construct compelling data-driven stories.
- CO5:** Apply advanced visualization tools and techniques for complex data analysis and real-time applications.

### Mapping of Course Outcomes with Program Outcomes:

CO / PO	PO1	PO2	PO3	PO4	PO5	PO6	PO7	PO8	PO9	PO10	PO11
<b>CO1</b>	3	2	2	2	1	2	2	1	2	2	3
<b>CO2</b>	2	3	2	2	1	2	3	1	2	2	3
<b>CO3</b>	2	3	2	2	1	3	3	2	2	2	3
<b>CO4</b>	3	3	3	2	2	3	3	2	3	3	3
<b>CO5</b>	2	3	2	3	1	2	2	3	2	2	3

### Mapping of Course Outcomes with Program Specific Outcomes:

COs	PSO1	PSO2	PSO3
<b>CO1</b>	3	2	2
<b>CO2</b>	3	3	2
<b>CO3</b>	3	3	2
<b>CO4</b>	3	3	3
<b>CO5</b>	2	2	3

### UNIT-I

**Introduction to Data Visualization:** Importance in business, Evolution of techniques, Gestalt principles, Cognitive aspects, Visual representations for categorical, numerical, and temporal data, Data type-based visualization, Use of color, layout, and typography.

### UNIT-II

**Data Preparation:** Data cleaning and preprocessing, Data conversion, handling missing data and outliers, merging datasets, Basic data reduction, Sampling, Data quality assessment, addressing biases and ethical concerns, Ensuring transparency and accuracy.

### UNIT- III

**Basic Visualization Techniques:** Bar and column charts, Line and area charts for trends, Pie and donut charts for composition, Scatter plots for relationships, Bubble charts, Histograms, Box plots for outliers, Heatmaps, Tree maps, Network graphs, Flow diagrams, Geographical maps, Waterfall, radar, and spider charts.

## UNIT- IV

**Data Dashboards and Storytelling:** Static vs Interactive Visualizations, Dashboard design, Filters and actions in dashboards, Visual storytelling techniques, structuring narratives, using visuals for storytelling, Animation for data understanding, Engaging stakeholders with data stories.

## UNIT- V

**Advanced Visualization Techniques and Applications:** Advanced tools and software, Visualization of complex datasets, Real-time data visualization, Interactive visualizations, Case studies and practical business applications.

### Textbooks:

1. Cole Nussbaumer Knaflig, Storytelling with Data (2015), Wiley, 1st Edition, ISBN: 978- 1119002253
2. Kieran Healy, Data Visualization: A Practical Introduction (2018), Princeton University Press, 1st Edition, ISBN: 9780691181622

### Reference Books:

1. Steve Wexler, Jeffrey Shaffer, Andy Cotgreave, The Big Book of Dashboards (2017) Wiley, 1st Edition, ISBN: 9781119282716
2. Nathan Yau, Visualize This (2011), Wiley, 1st Edition, ISBN:978-0470944882

### Web Links:

1. [Biological data analysis and visualization with R - Course](#)
2. [Data Analytics with Python - Course](#)

**Relevant cases have to be discussed in each unit and in examination case study is compulsory from any unit**

**ABILITY ENHANCEMENT COURSES  
 FUNDAMENTAL COGNITIVE SKILLS FOR MANAGERS**

**L    T    P    C**  
**1    1**

**Course Code: 2507BA25**

**Course Outcomes:**

**At the end of the course, students will be able to:**

- CO1:** Recognize the different aspects of the English language proficiency with emphasis on LSRW skills.
- CO2:** Apply communication skills through various language learning activities
- CO3:** Analyze the English speech sounds, stress, rhythm, intonation and syllable division for better listening and speaking comprehension.
- CO4:** Enable them to learn and apply fundamentals of English grammar concepts for improved language
- CO5:** Make use of various types of vocabulary in different academic and professional Careers

**Mapping of Course Outcomes with Program Outcomes:**

COs / POs	PO1	PO2	PO3	PO4	PO5	PO6	PO7	PO8	PO9	PO10	PO11
<b>CO1</b>	2	2	1	-	2	-	-	1	3	3	1
<b>CO2</b>	2	2	1	-	2	-	-	1	3	3	1
<b>CO3</b>	1	1	2	-	2	-	-	1	3	2	2
<b>CO4</b>	2	1	2	-	2	-	-	1	2	2	1
<b>CO5</b>	2	1	2	-	2	-	-	1	3	2	1

**Mapping of Course Outcomes with Program Specific Outcomes:**

CO / PSO	PSO1	PSO2	PSO3
<b>CO1</b>	1	1	1
<b>CO2</b>	1	1	1
<b>CO3</b>	1	1	1
<b>CO4</b>	1	1	1
<b>CO5</b>	1	1	1

**UNIT – I**

**Outstanding people A/B/C/D**

- Listening**                      Conversation about Jocelyn Bell- Burnell, Podcast: The 30-day challenge, Starting a new job, Conversation about technology
- Speaking**                      Discussing inspiring people, Asking and answering questions about challenges, explaining a process; Checking understanding, Discussing technology.
- Reading**                        Articles: Protector of the sea and the woman who reinvented children’s TV, Interviews: 30-day challenge, Article: Tech free!

**UNIT – II**
**Survival A/B/C/D**

<b>Listening</b>	Conversation about a survival situation, Interview: The Tiger, Cooking for a friend, Talking about getting lost
<b>Speaking</b>	Telling a survival story, Giving advice; Asking questions, Giving compliments and responding, Discussing the natural environment
<b>Reading</b>	Article: Lost at sea, Leaflet: How to survive...an animal attack, Leaflet: Be wise and survive
<b>Writing</b>	Guidelines, organizing guidelines in a leaflet
<b>Grammar</b>	Narrative tense, Future time clauses and conditionals
<b>Vocabulary</b>	Expressions with get, Animals and the environment
<b>Pronunciation</b>	Sound and Spelling: g, Intonation in question tags

**UNIT – III**
**Talent A/B/C/D**

<b>Listening</b>	Conversation: learning experiences, Radio Programme: The sports gene, Making wedding plans, Interviews about sport
<b>Speaking</b>	Talking about something you have put a lot of effort into, Discussing sport and ways to improve performance, planning a party, Talking about popular sports
<b>Reading</b>	Text about learning; Learning to learn, Article: Born to be the best; Three articles about athletes, Article: Fitness: Seattle snapshot
<b>Writing</b>	Article describing data
<b>Grammar</b>	Multi-word verbs, Present perfect and present perfect continuous
<b>Vocabulary</b>	Ability and achievement, word connected with sport
<b>Pronunciation</b>	Word stress, sound and spelling consonant sounds

**UNIT – IV**
**Life Lessons A/B/C/D**

<b>Listening</b>	Interview: Psychology of money; Two monologues: Life-changing events, Two monologues; training for a job, Presenting photos, Three monologues; living in different places
<b>Speaking</b>	Talking about how your life has changes, Discuss experiences of training and rules, Describing photos: Expressing careful disagreement, Discussing living in a different country
<b>Reading</b>	Two texts about life-changing events that helped people become rich, Article: Training for the emergency frontline, Advert for being an international student ‘buddy’
<b>Writing</b>	Job application, Giving a positive impression
<b>Grammar</b>	Used to and would
<b>Vocabulary</b>	Cause and result, Talking about difficulty
<b>Pronunciation</b>	Sound and spelling: u

**UNIT – V**
**Chance A/B/C/D**

<b>Listening</b>	Monologue: What are your chances?, Conversation: Talking about work, Money problems, News reports: environmental problems
<b>Speaking</b>	Discussing possible future events, Role Play: job interview,
<b>Reading</b>	Explaining and responding to an idea for a café, Giving opinions on environmental problems Quiz: Are you an optimist or a pessimist?; Article: Why we think we're going to have a long and happy life, Quiz: The unknown continent; Article: Cooking in Antarctica, Essay about protecting the environment
<b>Writing</b>	For and against essay, Arguing for and against an idea
<b>Grammar</b>	Future probability, Future perfect and future continuous
<b>Vocabulary</b>	Adjectives describing attitude, The natural world
<b>Pronunciation</b>	Sound and spelling : th, Intonation groups

**Textbook:**

1. K. Alex, A Course in Communication and Soft Skills (2021), S. Chand Publishing, 3rd Edition, ISBN: 9789358700749
2. Nitin Bhatnagar, Soft Skills and Personality Development (2011), Pearson, 1st Edition, ISBN: 978-8131760345

**Suggested Software:**

1. Cambridge Empower
2. SoftX(K-Van Solutions)

**Reference Books:**

1. Krishna Mohan & Meera Banerji, Developing Soft Skills (2009), Pearson, 2nd Edition, ISBN: 978-0230638433
2. Barun Mitra, Personality Development and Soft Skills (2016), Oxford, 2nd Edition, ISBN:978-0199459742

**Web Links:**

1. <https://www.cambridgeone.org/login>
2. <https://www.britishcouncil.in/english/online>
3. [www.englishmedialab.com](http://www.englishmedialab.com)



**Pronunciation** Consonant clusters, Consonant sounds

**UNIT –II**  
**City living A/B/C/D**

**Listening** Interview: ‘Smart’ cities: Two monologues talking about ‘smart’ cities, Two monologues: house renovations, Flat hunting, Interviews about a new shopping centre  
**Speaking** Discussing good and bad points about a city  
**Reading** Article: Quick-slow down!, Article: Who puts the ‘real’ in reality TV? Email: Complaining about an important issue.  
**Writing** Email of complaint, Using formal language  
**Grammar** Too/enough; so/such, Causative have/get  
**Vocabulary** Describing life in cities, Film and TV; Houses  
**Pronunciation** Sound and spelling: o, Stress in compound nouns

**UNIT – III**  
**Dilemmas A/B/C/D**

**Listening** Radio programme: person finance, Three monologues about honesty, Going to the bank, Conversation about a TV programme  
**Speaking** Giving opinions on financial matters, Discussing moral dilemmas, Talking about hopes and worries Discussing programmes about crime  
**Reading** Article: Is it time to give up on cash?, Newspaper article: The honesty experiment, Review: Crime with a smile  
**Writing** Review, Organising a review  
**Grammar** First and second conditionals, Third conditional; should have+past participle  
**Vocabulary** Money and finance, Crime  
**Pronunciation** Stressed and unstressed words; Sound and spelling: l, Word groups

**UNIT –IV**  
**Discoveries A/B/C/D**

**Listening** Conversation about inventions, Conversation about an email hoax, Finding the perfect flat, Four monologues about alternative medicine  
**Speaking** Talking about inventions, describing a hoax or a scam or a case of fraud, Giving and receiving surprises  
**Reading** Article: Too good to be true?, Article: The rise and fall of Barry Minkow, Essay: The Value of alternative medicine  
**Writing** Opinion essay, Presenting a series of arguments  
**Grammar** Relative clauses, Reported speech; Reporting verbs  
**Vocabulary** Health, Verbs describing thought and knowledge  
**Pronunciation** Sound and spelling : ui, Linking and intrusion

**UNIT – V**  
**Possibilities A/B/C/D**

**Listening** Interview about Dan Cooper, Two monologues: pursuing a dream, Celebrating good news, conversation about goals

<b>Speaking</b>	Telling stories about coincidences, Describing and comparing brave or amazing people, Telling an important piece of news, Talking about performing
<b>Reading</b>	Story: The man who disappeared; Blog: The Wreck of the Titan, Article: Dream to help, Story: Rosa's diary: The ultimate goal
<b>Writing</b>	Story, Making a story interesting
<b>Grammar</b>	Past modals of deduction, Wishes and regrets
<b>Vocabulary</b>	Adjectives with prefixes, Verbs of effort
<b>Pronunciation</b>	Word stress, Linking, Consonant clusters

**Textbook:**

1. Suzanne C. de Janasz, Karen O. Dowd, Beth Z. Schneider, Interpersonal Skills in Organizations (2018), McGraw Hill, 5th Edition, ISBN: 9781259870435
2. M.S. Rao, Enhancing Soft Skills for Managers (2013), I.K. International Publishing, 1st Edition., ISBN: 978-9380578385.

**Suggested Software:**

1. Cambridge Empower
2. SoftX(K-Van Solutions)

**Reference Books:**

1. Sabina Pillai & Agna Fernandez, Soft Skills and Employability Skills(2017) Cambridge University Press, 1st Edition, ISBN: 978-1316981320
2. Daniel Goleman, Emotional Intelligence: Why It Can Matter More Than IQ (2006), Bantam Books, 10th Anniversary Edition, ISBN: 9780553383713

**Web Links:**

1. <https://www.cambridgeone.org/login>
2. <https://www.coursera.org/>
3. <https://www.skillshare.com/>
4. <https://www.mindtools.com/cawh8bu/communication-tools>

## EMPLOYABILITY SKILLS- V

L T P C  
1

Course Code: 2507BA08

### Course Outcomes:

**At the end of the Course, Student will be able to:**

- CO1:** Apply principles of permutations, combinations, probability, and logarithms to solve quantitative aptitude problems.
- CO2:** Interpret and analyze data from charts, graphs, and statistical tables for decision-making and accuracy.
- CO3:** Evaluate logical reasoning statements involving arguments, assumptions, conclusions, and data sufficiency.
- CO4:** Solve puzzle and eligibility test problems using analytical and critical thinking skills.
- CO5:** Demonstrate effective interpersonal, communication, and time management skills for successful personal and professional interactions.

### Mapping of Course Outcomes with Program Outcomes:

COs / POs	PO1	PO2	PO3	PO4	PO5	PO6	PO7	PO8	PO9	PO10	PO11
CO1	3	2	–	–	–	–	–	–	–	–	2
CO2	2	3	2	–	–	–	–	–	2	–	2
CO3	–	3	3	–	2	–	–	–	–	–	2
CO4	–	2	3	–	–	–	–	–	–	–	2
CO5	–	–	–	3	2	3	2	3	2	3	3

### Mapping of Course Outcomes with Program Specific Outcomes:

CO \ PSO	PSO1	PSO2	PSO3
CO1	2	2	–
CO2	2	3	–
CO3	–	2	3
CO4	–	2	2
CO5	–	–	3

### Aptitude:

Permutations and Combinations, Probability, Data Interpretation, Logarithms, Statistics

### Reasoning:

Puzzle Tests, Eligibility Test, Data Sufficiency, Statements – Arguments, Statements – Assumptions, Statements - Course of Action, Statements - Conclusions

### Verbal:

Interview skills, Grammar in use, Interpersonal Skills, Negotiation Skills, Social Skills, Problem-Solving Skills, Time Management Skills

### Text Books:

- Nitin Bhatnagar, Soft Skills and Personality Development(2020), Pearson, 1st Edition, ISBN: 9788131760345,
- Krishna Mohan & Meera Banerji, Developing Soft Skills (2009), Pearson, 2nd Edition, ISBN: 978-

0230638433

**Reference Books:**

1. Barun Mitra, Personality Development and Soft Skills (2016), Oxford University Press, 2nd Edition, ISBN: 9780199459742.
2. K. Alex, Soft Skills (2009), S. Chand Publishing, 3rd Edition, ISBN:9788121931922

**Web Links:**

1. [www.indiabix.com](http://www.indiabix.com)
2. [www.bankersadda.com](http://www.bankersadda.com)

**MULTI-DISCIPLINARY COURSES  
IT & AI SKILLS**

<b>Course Code: 2507BA28</b>	<b>L</b>	<b>T</b>	<b>P</b>	<b>C</b>
	<b>1</b>		<b>2</b>	<b>3</b>

**Course Outcomes:**

**At the end of the Course, Student will be able to:**

- CO1:** Explain the fundamentals of computers and their applications in business.
- CO2:** Build and format professional documents using MS Word.
- CO3:** Design and present impactful business presentations in MS PowerPoint.
- CO4:** Integrate and apply AI tools across MS Excel applications
- CO5:** Analyze and visualize business data using MS Excel's functions.

**Mapping of Course Outcomes with Program Outcomes:**

CO / PO	PO1	PO2	PO3	PO4	PO5	PO6	PO7	PO8	PO9	PO10	PO11
<b>CO1</b>	3	1	1	–	1	–	–	1	3	–	2
<b>CO2</b>	2	1	1	2	1	–	–	–	3	–	2
<b>CO3</b>	2	1	1	3	1	1	–	–	3	2	2
<b>CO4</b>	2	2	2	1	1	–	1	–	3	1	3
<b>CO5</b>	2	3	3	1	1	–	1	–	3	1	3

**Mapping of Course Outcomes with Program Specific Outcomes:**

CO / PSO	PSO1	PSO2	PSO3
<b>CO1</b>	1	1	2
<b>CO2</b>	1	1	2
<b>CO3</b>	1	1	2
<b>CO4</b>	2	2	3
<b>CO5</b>	2	3	3

**UNIT – I**

**Introduction to Computers:** Definition, Components, Types; generations of computer; Computer Memory, Software and Hardware, Operating Systems. Window features. Introduction to Internet-benefit and limitation, IP address, Browser, E-mail.

**UNIT – II**

**MS Word:** Interface and Navigation; Document Formatting, Text Formatting, Paragraph Formatting, Advanced Features, Tables, Charts, and SmartArt, Mail Merge; AI Tools for MS Word.

**UNIT – III**

**MS PowerPoint:** Interface and Navigation; Slide Design and Layout, Adding and Formatting Text, Using Themes and Templates, Multimedia in Presentations, Presentation Tools, Slide Master and Custom Layouts, Slide Show Setup and Presentation Delivery; AI Tools for MS PowerPoint.

#### **UNIT – IV**

**MS Excel:** Interface and Navigation, Creating, Saving, and, Opening Workbooks, Basic Spread sheet Operations, Entering and Formatting Data, Basic Formulas and Functions, Sorting and Filtering Data, Data Visualization, Creating and Customizing Charts Conditional Formatting; AI Tools for MS Excel.

#### **UNIT – V**

**Advanced Excel:** Lookup Functions: VLOOKUP, HLOOKUP, and XLOOKUP; Logical Functions: IF, AND, OR; Text Functions: CONCATENATE, LEFT, RIGHT; Date and Time Functions: DATE, TODAY, NETWORKDAYS.

**Data Analysis and Visualization:** PivotTables-Creating and analyzing data with PivotTables; Charts and Graphs: Designing and customizing basic charts; Conditional Formatting: Applying rules to highlight key data points.

**Data Cleaning Techniques:** Using Text to Columns and Remove Duplicates; Data Validation: Setting up rules to ensure data accuracy; Importing Data: Importing data from external sources like CSV and databases.

#### **Text Books:**

1. George Reynolds and Judith S. Reynolds, Information Technology for Managers (2022). Pearson Education. ISBN-10:1305482492, ISBN-13:9781305482494.
2. Alexis Khosla, Computer Fundamentals and Information Technology (2022). BPB Publications. ISBN-13. 9781305389830

#### **Reference Books:**

1. C.S.V. Murthy, Information Technology for Management (2022). Himalaya Publishing House. ISBN 81-7866-201-9.
2. K.C. Laudon and Jane P. Laudon, India Information Technology: An Introduction (2021). Pearson Education. ISBN-10:9789352865475, ISBN-13:978- 9352865475.

#### **Web Links:**

1. [https://onlinecourses.swayam2.ac.in/cec20\\_cs05/preview](https://onlinecourses.swayam2.ac.in/cec20_cs05/preview)
2. [https://onlinecourses.nptel.ac.in/noc22\\_mg35/preview](https://onlinecourses.nptel.ac.in/noc22_mg35/preview)

**Relevant cases have to be discussed in each unit and in examination case study is compulsory from any unit.**

## MEDIA LITERACY AND CRITICAL THINKING

<b>Course Code: 2507BA31</b>	<b>L</b>	<b>T</b>	<b>P</b>	<b>C</b>
	<b>2</b>			<b>2</b>

### Course Outcomes:

**At the end of the Course, Student will be able to:**

- CO1:** Explain the notions of media, media literacy, main media types and formats
- CO2:** Identify the benefits and drawbacks of traditional and new media
- CO3:** Estimate the role and strategies of the media market players
- CO4:** Analyze the impact of different types of media content and narratives
- CO5:** Evaluate multimedia messages based on journalistic standards.

### Mapping of Course Outcomes with Program Outcomes:

CO / PO	PO1	PO2	PO3	PO4	PO5	PO6	PO7	PO8	PO9	PO10	PO11
<b>CO1</b>	2	2	2	1	2	1	1	2	2	2	2
<b>CO2</b>	2	2	2	1	2	1	2	2	2	2	2
<b>CO3</b>	2	2	3	2	3	1	2	2	2	2	2
<b>CO4</b>	2	3	3	2	3	1	2	3	2	3	2
<b>CO5</b>	2	3	3	2	3	1	2	2	2	3	3

### Mapping of Course Outcomes with Program Specific Outcomes:

CO / PSO	PSO1	PSO2	PSO3
<b>CO1</b>	2	1	2
<b>CO2</b>	2	1	2
<b>CO3</b>	2	1	2
<b>CO4</b>	2	2	3
<b>CO5</b>	2	2	3

### UNIT – I

**Introduction to Media.:** The notions of media and media literacy, History of media evolution, Forms and formats of media

### UNIT – II

**Traditional vs New media:** Role and functions of Traditional and New Media, Social Media Platforms, Access to information

### UNIT – III

**Media Market Game:** Rules and players- Media market players, Ownership and control of mass media market, Journalistic standards

### UNIT – IV

**Media content:** Types and Narratives: The notion and types of media content, The notion and modes of narrative, Media narrative power

### UNIT – V

**Multimedia content:** Types and Technologies: Multimedia terms and features, Multimedia formats and

components, Multimedia messages

**Textbooks:**

1. Chris Sperry & Cyndy Scheibe, Teaching Students to Decode the World: Media Literacy and Critical Thinking Across the Curriculum (February 2022), ASCDBN-13: 978-1416630937.
2. McQuail D. McQuail's Mass Communication Theory. Sage Publications. 6th Edition. ISBN-10:1849202923, ISBN-13: 978-1849202923

**Reference Books:**

1. Potter, W.J., Media Literacy (2021), SAGE Publishing, 10th edition, 504 p. ISBN-10:1071814451, ISBN-13:978-1071814451
2. Nick Pernisco, Media Literacy: An Essential Guide to Critical Thinking Skills for Our Complex Digital World (July 29, 2020), Independently published ISBN-13: 978- 1087896304.

**Web Links:**

1. <https://mediasmarts.ca/digital-media-literacy/general-information/digital-media-literacyfundamentals/media-literacy-fundamentals>
2. <http://www.hks.harvard.edu/fs/pnorris/Conference/Conference%20papers/Coronel%20Watchdog.pdf>

**Relevant cases have to be discussed in each unit and in examination case study is compulsory from any unit.**

**VALUE ADDED COURSES**  
**ENVIRONMENTAL SCIENCE AND SUSTAINABILITY**

<b>Course Code: 2507BA23</b>	<b>L</b>	<b>T</b>	<b>P</b>	<b>C</b>
	<b>2</b>			<b>2</b>

**Course Outcomes:**

**At the end of the Course, Student will be able to:**

- CO1:** Explain the functions of environment, ecosystems and biodiversity and their conservation.
- CO2:** Identify the causes, effects of environmental pollution and natural disasters and contribute to the preventive measures in the society.
- CO3:** Apply the understanding of renewable and non-renewable resources and contribute to the sustainable measures to preserve them for future generations.
- CO4:** Describe various environmental acts
- CO5:** Recognize the different goals of sustainable development and apply them for suitable technological advancement and societal development.

**Mapping of Course Outcomes with Program Outcomes:**

CO / PO	PO1	PO2	PO3	PO4	PO5	PO6	PO7	PO8	PO9	PO10	PO11
<b>CO1</b>	1	1	1	–	2	–	–	3	–	–	1
<b>CO2</b>	1	2	2	–	3	1	1	3	–	–	1
<b>CO3</b>	1	2	2	–	2	1	3	3	2	–	1
<b>CO4</b>	–	1	1	–	3	1	–	2	–	–	–
<b>CO5</b>	1	2	2	1	3	2	2	3	2	1	2

**Mapping of Course Outcomes with Program Specific Outcomes:**

CO / PSO	PSO1	PSO2	PSO3
<b>CO1</b>	1	–	2
<b>CO2</b>	1	2	2
<b>CO3</b>	2	2	3
<b>CO4</b>	1	1	2
<b>CO5</b>	2	2	3

**UNIT – I**

**Environment and Biodiversity:** Definition, scope and importance of environment – need for public awareness. Eco-system and Energy flow– ecological succession. Types of biodiversity.

**UNIT – II**

**Environmental Pollution:** Causes, Effects and Preventive measures of Water, Soil, Air and Noise Pollutions. Solid, Hazardous and E-Waste management, Environmental protection acts.

**UNIT – III**

**Renewable Sources of Energy:** Energy management and conservation, New Energy Sources: Need of new sources. Different types new energy sources.

**UNIT – IV**

**Environmental Acts:** The Water (Prevention and Control of Pollution) Act, 1974-The Air (Prevention

and Control of Pollution) Act, 1981-The Environment (Protection) Act, 1986 Objectives.

#### **UNIT – V**

**Sustainability Practices:** Zero waste and R concept, Circular economy, ISO 14000 Series, Material Life cycle assessment, Environmental Impact Assessment.

#### **Textbooks:**

1. Benny Joseph, *Environmental Science and Engineering* , Tata McGraw-Hill, New Delhi.ISBN-10:9387432351, ISBN-13: 978-9387432352.
2. Anubha Kaushik and C. P. Kaushik's —*Perspectives in Environmental Studies*l, 6th Edition, New Age International Publishers.ISBN-10:9789386418630, ISBN-13:978- 9386418630.

#### **Reference Books:**

1. R.K. Trivedi, *Handbook of Environmental Laws, Rules, Guidelines, Compliances and Standards*, Vol. I and II, Enviro Media. ISBN-10: 8178002213, ISBN-13:978- 8178002217.
2. Cunningham, W.P. Cooper, T.H. Gorhani, *Environmental Encyclopedia*, Jaico Publ., House, Mumbai. ISBN-10:8172247869, ISBN-13: 978-8172247867.

#### **Web Links:**

1. [https://onlinecourses.nptel.ac.in/noc23\\_hs155/preview](https://onlinecourses.nptel.ac.in/noc23_hs155/preview)
2. [https://onlinecourses.swayam2.ac.in/nou20\\_ag12/preview](https://onlinecourses.swayam2.ac.in/nou20_ag12/preview)

## INDIAN CONSTITUTION

**Course Code: 2507BA26**

<b>L</b>	<b>T</b>	<b>P</b>	<b>C</b>
<b>2</b>			<b>2</b>

**Course Outcomes:**

**At the end of the Course, Student will be able to:**

- CO1:** Identify and explore the basic features and modalities about Indian constitution
- CO2:** Explain the fundamental and administrative structure of various branches of Government
- CO3:** Differentiate and relate the functioning of Indian parliamentary system at the centre and state level.
- CO4:** Examine different aspects of Indian Legal System and its related bodies.
- CO5:** Understand and abide the federal distribution and powers of the Indian constitution

**Mapping of Course Outcomes with Program Outcomes:**

<b>CO / PO</b>	<b>PO1</b>	<b>PO2</b>	<b>PO3</b>	<b>PO4</b>	<b>PO5</b>	<b>PO6</b>	<b>PO7</b>	<b>PO8</b>	<b>PO9</b>	<b>PO10</b>	<b>PO11</b>
<b>CO1</b>	2	2	1	2	1	2	2	3	1	2	2
<b>CO2</b>	2	2	2	2	1	1	2	2	2	2	2
<b>CO3</b>	2	2	2	2	1	1	2	2	2	2	2
<b>CO4</b>	2	2	3	2	2	2	2	3	2	2	2
<b>CO5</b>	2	2	3	2	2	2	2	3	2	2	2

**Mapping of Course Outcomes with Program Specific Outcomes:**

<b>CO / PSO</b>	<b>PSO1</b>	<b>PSO2</b>	<b>PSO3</b>
<b>CO1</b>	2	2	2
<b>CO2</b>	2	2	2
<b>CO3</b>	2	2	2
<b>CO4</b>	2	2	2
<b>CO5</b>	2	2	2

**UNIT – I**

**Constitution:** Meaning & Constitutionalism, Historical perspective -: 1909 Act, 1919 Act & 1935 Act, Salient features & nature of the Constitution,

**UNIT – II**

**Fundamental Rights:** Introduction & its scheme, Right to Equality (Art.14), Right to Fundamental Freedoms (Art. 19), Right to Life (Art. 21), Directive Principles of State Policy: importance and implementation, Fundamental Duties and its legal status.

**UNIT – III**

**Union Government** – Structures of the Union Government and Functions – President – Vice President – Prime Minister – Cabinet – Parliament – Supreme Court of India – Judicial Review.

**UNIT – IV**

**State Government** – Structure and Functions – Governor – Chief Minister – Cabinet – State Legislature – Judicial System in States – High Courts and other Subordinate Courts.

## UNIT – V

**Federal structure:** Federal structure & distribution of legislative and financial powers between the Union and the States.

### Text Books:

1. D.D. Basu, Introduction to the Constitution of India, Lexis Nexis, New Delhi, ISBN 10-9388548868.
2. Subhash C. Kashyap, Indian Constitution, National Book Trust, New Delhi. ISBN- 10: 9352704428, ISBN-13:978-8123707341.

### Reference Books:

1. Dr. G. B. Reddy & Mohd. Suhaib, Constitution of India and Professional Ethics, Dream tech Press, ISBN-10:818986601X, ISBN-13:978-8189866013.
2. B.Z. Fadia & Kuldeep Fadia, Indian Government & Politics, Lexis Nexis, New Delhi, ISBN-10: 9384885622, ISBN-13: 978-9384885625.

### Web Links:

1. <https://archive.nptel.ac.in/courses/129/106/129106003/>
2. [https://onlinecourses.nptel.ac.in/noc24\\_lw05/preview](https://onlinecourses.nptel.ac.in/noc24_lw05/preview)

## INTERNATIONAL BUSIENSS

<b>Course Code: 2507BA41</b>	<b>L</b>	<b>T</b>	<b>P</b>	<b>C</b>
	<b>2</b>		<b>1</b>	<b>3</b>

### Course Outcomes:

**At the end of the Course, Student will be able to:**

- CO1:** Understand the fundamental concepts of international business, stages of internationalization, and global business environments.
- CO2:** Analyze classical and modern international trade theories and evaluate the impact of tariff and non-tariff barriers on global trade.
- CO3:** Interpret the role of Foreign Direct Investment (FDI), international institutions, and investment models in shaping global economic flows.
- CO4:** Evaluate regional economic integrations, trade blocs, and multilateral trade agreements, and their implications for business decisions.
- CO5:** Assess emerging trends in international business, including digital trade, CSR, ESG practices, and the impact of geopolitical and environmental shifts

### Mapping of Course Outcomes with Program Outcomes:

CO / PO	PO1	PO2	PO3	PO4	PO5	PO6	PO7	PO8	PO9	PO10	PO11
<b>CO1</b>	3	2	2	3	3	2	2	2	2	2	3
<b>CO2</b>	3	3	3	2	2	2	2	2	2	2	3
<b>CO3</b>	3	3	3	2	3	2	2	2	2	2	3
<b>CO4</b>	3	3	3	3	3	3	2	2	2	3	3
<b>CO5</b>	3	3	3	3	3	3	3	3	3	3	3

### Mapping of Course Outcomes with Program Specific Outcomes:

CO / PSO	PSO1	PSO2	PSO3
<b>CO1</b>	3	2	2
<b>CO2</b>	3	3	2
<b>CO3</b>	3	3	3
<b>CO4</b>	3	3	3
<b>CO5</b>	3	3	3

### UNIT 1:

**Fundamentals of International Business:** Introduction to international business, Nature and scope, Stages of internationalization, EPRG framework (Ethnocentric, Polycentric, Regiocentric, Geocentric), Globalization and its impact, International business environment – economic, political, cultural, legal.

### UNIT 2:

**International Trade Theories and Barriers:** Mercantilist theory, Absolute advantage, Comparative advantage, Factor proportions theory, Neo-factor proportions theory, Country similarity theory, Intra-industry trade, Tariff barriers, Non-tariff barriers, Role of WTO in trade liberalization.

**UNIT 3:**

**Foreign Direct Investment and Global Institutions:** Definition of FDI, Greenfield and Brownfield FDI, Theories of FDI, Benefits and costs of FDI, Trends in global FDI, CAGE model (Cultural, Administrative, Geographic, Economic distance), Role of international institutions – IMF, World Bank, UNCTAD.

**UNIT 4:**

**Economic Integration and Trade Agreements:** Economic indicators and business decisions, Regional economic integration – Free trade area, Customs union, Common market, Economic union, Regional trade blocs – EU, NAFTA, ASEAN, SAARC, Multilateral trade negotiations, Instruments of trade regulation, Emerging markets and developing economies.

**UNIT 5:**

**Contemporary Trends and Challenges in International Business:** International entrepreneurship, Born global firms, Corporate social responsibility (CSR), ESG investing and reporting, Corporate responses to climate change and social justice, Brexit and international business laws, Rise of digital platforms, E-commerce trends, Re-shoring and near-shoring, Impact of COVID-19 on international business.

**Text Books:**

1. S. Tamer Cavusgil, Gary Knight, John R. Riesenberger, International Business: The New Realities (Date: July 2, 2024), Pearson Publication, 6th Edition, ISBN-13: 978- 0138183769
2. Charles W.L. Hill, International Business: Competing in the Global Marketplace (2025, McGraw Hill, 14th Edition, and ISBN-13: 978-1260387544.

**Reference Books:**

1. John J. Wild and Kenneth L. Wild, International Business: The Challenges of Globalization (2022), Pearson Education, 9th Edition,
2. Jeffrey F. Beatty, Susan S. Samuelson, Patricia Sanchez Abril, International Business Law and Its Environment (2025), Publisher: Cengage, 11th Edition, ISBN-13: 978-0357717868.

**Web Links:**

1. [https://books.google.com/books/about/International\\_Business\\_2e.html?id=c3GGYIMWWMQ\\_C](https://books.google.com/books/about/International_Business_2e.html?id=c3GGYIMWWMQ_C)
2. <https://www.amazon.in/International-Business-2e-K-Aswathappa/dp/007059953X>

**Relevant cases have to be discussed in each unit and in examination case study is compulsory from any unit.**

## PUBLIC HEALTHER AND MANAGEMENT

**Course Code: 2507BA44**

<b>L</b>	<b>T</b>	<b>P</b>	<b>C</b>
2			2

### Course Outcomes:

**At the end of the Course, Student will be able to:**

- CO1:** Explain the key concepts, evolution, and global frameworks of public health.
- CO2:** Identify the role of social determinants and health equity in public health outcomes.
- CO3:** Describe the structure, issues, and major programmes of the Indian health system.
- CO4:** Apply basic planning and management tools in public health settings.
- CO5:** Analyze public health programmes using monitoring, evaluation, and health system frameworks.

### Mapping of Course Outcomes with Program Outcomes:

CO / PO	PO1	PO2	PO3	PO4	PO5	PO6	PO7	PO8	PO9	PO10	PO11
<b>CO1</b>	3	2	2	1	3	1	2	1	1	1	2
<b>CO2</b>	2	2	1	3	3	2	3	1	1	2	1
<b>CO3</b>	3	3	2	1	2	3	2	1	1	2	2
<b>CO4</b>	3	3	3	2	2	3	1	2	2	1	2
<b>CO5</b>	3	3	3	2	2	3	1	2	2	1	3

### Mapping of Course Outcomes with Program Specific Outcomes:

CO / PSO	PSO1	PSO2	PSO3
<b>CO1</b>	2	2	1
<b>CO2</b>	2	2	2
<b>CO3</b>	3	2	2
<b>CO4</b>	3	3	3
<b>CO5</b>	3	3	3

### UNIT I:

**Foundations of Public Health:** Concept of public health and its role in society, evolution of public health, understanding health and disease, and global health frameworks.

### UNIT II:

**Health Determinants and Equity:** Health equity, social determinants of health, access to healthcare and social justice, and the role of public health in reducing disparities.

### UNIT III:

**Health Systems in India:** History of public health in India, organization of health systems in India, key issues in India's health system, and major health schemes and programmes including the National Health Mission, Integrated Child Development Services (ICDS), Janani Suraksha Yojana, Ayushman Bharat Scheme, and POSHAN Abhiyan.

**UNIT IV:**

**Health Planning and Management:** Concepts of planning from macro to micro level, tools for health planning, district-level health management, and strategies for effective implementation.

**UNIT V:**

**Monitoring, Evaluation, and Frameworks:** Introduction to monitoring and evaluation (M&E), purpose and process of M&E in public health, health system frameworks, and application of frameworks in programme assessment.

**Text Books:**

1. Goldstein RL, Goldstein K, Dwelle TL Introduction to Public Health: Promises and Practices, Springer Publishing Company.
2. Sen A, Health in Development, Bulletin of the World Health Organization, Vol. 77(8).

**Reference Books:**

1. R N Batta, Public health management in India: Concerns and options, Journal of Public Administration and Policy Research, Vol. 7(3).
2. National Health Policy 2017, Ministry of Health and Family Welfare, Govt. of India.

**Web Links:**

1. <https://nptel.ac.in/courses/121106007>
2. <https://nptel.ac.in/courses/127106227>

**Relevant cases have to be discussed in each unit, and in examination, case study is compulsory from any unit.**

**SKILL ENHANCEMENT COURSES  
EMERGING TECHNOLOGIES AND APPLICATION**

<b>Course Code: 2507BA22</b>	<b>L</b>	<b>T</b>	<b>P</b>	<b>C</b>
	<b>2</b>			<b>3</b>

**Course Outcomes:**

**At the end of the Course, Student will be able to:**

- CO1:** Identify different emerging technologies
- CO2:** Explain the Basics of data science.
- CO3:** Identify fundamentals of Artificial Intelligence
- CO4:** Assess the latest developments in the area of technology to support business
- CO5:** Analyze the basic concepts of AR & VR

**Mapping of Course Outcomes with Program Outcomes:**

CO / PO	PO1	PO2	PO3	PO4	PO5	PO6	PO7	PO8	PO9	PO10	PO11
<b>CO1</b>	2	2	1	2	2	2	3	2	1	3	3
<b>CO2</b>	2	3	2	2	1	2	3	1	2	3	3
<b>CO3</b>	2	3	2	2	1	2	3	1	2	3	3
<b>CO4</b>	3	3	3	3	2	3	3	2	2	3	3
<b>CO5</b>	2	2	2	2	2	2	3	1	2	3	3

**Mapping of Course Outcomes with Program Specific Outcomes:**

CO / PSO	PSO1	PSO2	PSO3
<b>CO1</b>	2	2	3
<b>CO2</b>	2	2	3
<b>CO3</b>	2	2	3
<b>CO4</b>	3	2	3
<b>CO5</b>	2	2	3

**UNIT – I**

**Cloud Computing:** Cloud models (IaaS, PaaS, SaaS), Deployment models (public, private, hybrid), Cloud-based solutions, Cost-benefit analysis, Security, Data compliance, Governance frameworks.

**UNIT – II**

**Internet of Things (IoT):** Sensor technologies, IoT applications (smart cities, infrastructure, industrial), Data processing, Real-time analytics, Impact on business models, Production and supply chain transformation.

**UNIT – III**

**Industry 4.0:** Concept of Industry 4.0, Smart manufacturing, Cyber-physical systems, Robotics, Business process optimization, Impact on production and supply chains.

**UNIT – IV**

**Blockchain Technology:** Blockchain fundamentals, Decentralized ledger, Cryptography, Smart contracts, Financial services, Security, Privacy, Regulatory challenges.

**UNIT – V**

**AR/VR:** AR/VR concepts, Applications in marketing and training, Immersive technologies, Challenges and opportunities, Technological advancements, Integration in business processes.

**Text Books:**

1. Mohamed Anis Bach Tobji, Rim Jallouli, Yamen Koubaa, Anton Nijholt, Digital Economy. Emerging Technologies and Business Innovation, ISBN-10:9783319977485, ISBN-13:978-3319977485.
2. Timothy Jung, M. Claudia tom Dieck , Augmented Reality and Virtual Reality: Empowering Human, Place and Business, (2019). ISBN-10: 3319877038, ISBN-13: 978-3319877037

**Reference Books:**

1. Paul Mealy , Virtual & Augmented Reality for Dummies. ISBN-13:9978-1119481348.
2. Dr. Sanjay Sharma , Emerging Technology (2022), ISBN: 9789392549151.

**Web Links:**

1. <https://nptel.ac.in/courses/106105166>
2. [https://onlinecourses.nptel.ac.in/noc22\\_cs53/preview](https://onlinecourses.nptel.ac.in/noc22_cs53/preview)

**Relevant cases have to be discussed in each unit and in examination case study is compulsory from any unit.**

## MANAGEMENT INFORMATION SYSTEMS

	<b>L</b>	<b>T</b>	<b>P</b>	<b>C</b>
<b>Course Code: 2507BA43</b>	<b>2</b>		<b>1</b>	<b>3</b>

**Course Outcomes:**

**At the end of the Course, Student will be able to:**

**CO1:** Explain the information needs of an organization and a business function

**CO2:** Identify the effectiveness of decision-making process and MIS design

**CO3:** Utilize DSS techniques for making effective decisions

**CO4:** Design parameters for information systems process and application

**CO5:** Apply DBMS to attain the goals of the organization

**Mapping of Course Outcomes with Program Outcomes:**

CO / PO	PO1	PO2	PO3	PO4	PO5	PO6	PO7	PO8	PO9	PO10	PO11
<b>CO1</b>	3	2	2	3	3	3	3	2	3	3	3
<b>CO2</b>	3	2	3	3	3	2	3	3	2	3	3
<b>CO3</b>	3	3	3	3	3	3	3	2	3	3	3
<b>CO4</b>	3	3	2	3	2	3	3	3	3	3	2
<b>CO5</b>	3	3	3	3	3	3	2	3	3	3	3

**Mapping of Course Outcomes with Program Specific Outcomes:**

CO / PSO	PSO1	PSO2	PSO3
<b>CO1</b>	3	2	2
<b>CO2</b>	3	3	2
<b>CO3</b>	3	3	3
<b>CO4</b>	3	3	3
<b>CO5</b>	3	3	3

**UNIT I:**

**Introduction to Management Information Systems (MIS):** Overview of MIS, types of MIS, dimensions and components of information systems (IS), benefits of MIS, IT infrastructure, evolution of IT infrastructure, and new approaches for system building in the digital era.

**UNIT II:**

**Database Management Systems (DBMS):** Objectives of database approach, characteristics of DBMS, data processing systems, components of DBMS packages, database administration, and the Entity-Relationship (ER) model.

**UNIT III:**

**Information System Applications:** MIS applications, Decision Support Systems (DSS), Group Decision Support Systems (GDSS), DSS applications in e-enterprise, Knowledge Management

Systems (KMS), Expert Systems (KBES), Enterprise Model Systems, E-business, E-commerce, E-communication, and Business Process Reengineering.

#### **UNIT IV:**

**Project Management Basics:** Objectives of project management, fundamentals of project management information systems (PMIS) with agile methodologies, introduction to SCRUM, roles and meetings, user stories, project risk management, and controlling risk factors.

#### **UNIT V:**

**Ethical, Social, and Political Issues in Information Systems:** Ethical, social, and political considerations in managing information systems, with a focus on the implications of these issues in the information era.

#### **Text Books:**

1. Bernd Schenk , Advanced Management Information Systems: Models, Concepts and Cases (2025) Springer Cham Publication, ISBN-13: 978-3031879036
2. Kenneth C. Laudon & Jane P. Laudon , Management Information Systems: Managing the Digital Firm(2021), Pearson, 17th Edition, ISBN-13: 978-0136971542

#### **Reference Books:**

1. Prasad L.M., Prasad Usha, Management Information Systems(2023), Sultan Chand & Sons, ISBN- 81-8054-814-7
2. Goyal, D.P., Management Information System, MACMILLAN India Limited, New Delhi. ISBN-10:403930996, ISBN-13: 978-1403930996

#### **Web Links:**

1. [https://onlinecourses.nptel.ac.in/noc20\\_mg60/preview](https://onlinecourses.nptel.ac.in/noc20_mg60/preview)
2. <https://archive.nptel.ac.in/courses/122/105/122105022/>

**Relevant cases have to be discussed in each unit and in examination case study is compulsory from any unit.**

## ENTERPRISE SYSTEM AND PLATFORMS

**Course Code: 2507BA39**

**L**  
**2**

**T**

**P**

**C**  
**2**

### Course Outcomes:

**At the end of the Course, Student will be able to:**

- CO1:** Understand enterprise systems, platforms, and business process integration.
- CO2:** Analyze ERP, SCM, CRM, and EAM functions in business operations.
- CO3:** Evaluate enterprise platforms like SAP, Oracle, and Microsoft Dynamics.
- CO4:** Explore business intelligence, big data analytics, and security in enterprise systems.
- CO5:** Examine emerging trends like AI, blockchain, and IoT in enterprise systems.

### Mapping of Course Outcomes with Program Outcomes:

CO / PO	PO1	PO2	PO3	PO4	PO5	PO6	PO7	PO8	PO9	PO10	PO11
<b>CO1</b>	3	2	1	2	1	2	3	1	2	2	1
<b>CO2</b>	3	3	2	2	1	3	3	2	3	2	1
<b>CO3</b>	3	3	2	2	2	3	3	1	2	2	1
<b>CO4</b>	2	3	1	2	2	3	3	2	2	3	2
<b>CO5</b>	2	2	2	2	2	3	3	2	2	3	2

### Mapping of Course Outcomes with Program Specific Outcomes:

CO / PSO	PSO1	PSO2	PSO3
<b>CO1</b>	2	2	3
<b>CO2</b>	2	2	3
<b>CO3</b>	2	2	3
<b>CO4</b>	1	2	3
<b>CO5</b>	2	2	3

#### UNIT I:

**Introduction to ERP:** Definition, evolution, and significance of ERP; Key drivers, components, and core modules (Finance, HR, Supply Chain); Benefits, challenges, and solutions in ERP implementation.

#### UNIT II:

**ERP System Design and Architecture:** ERP system design, SDLC for ERPs, Customization vs. Standardization; ERP architecture including Three-Tier Architecture; System integration and compatibility.

#### UNIT III:

**ERP Vendors and Solutions:** Overview of major ERP vendors (SAP, Oracle, Microsoft, etc.); Comparative study of ERP solutions; Selection criteria based on business needs and scale.

#### UNIT IV:

**ERP Implementation and Management:** Implementation strategies, project planning, data migration, integration; Risk management, training, post-implementation support, and continuous improvement.

**UNIT V:**

**Advanced ERP and Future Trends:** Advanced ERP features, BI & analytics, cloud-based ERP; Emerging technologies like IoT, AI & ML in ERP; ERP's role in business strategy and digital transformation.

**Text Books:**

1. Paige Baltzan & Amy Phillips , Business Driven Information Systems (2025) McGraw Hill Publication , 9th Edition, ISBN-13: 978-1264638727
2. Johan Magnusson , Enterprise System Platforms (2025) Student litteratur AB Publication ISBN-13: 978-9144096704

**Reference Books:**

1. Veena Bansal , Enterprise Resource Planning: A Managerial Perspective(May 2024) , Pearson India ISBN-13: 9781306254311
2. Luvai F. Motiwalla & Jeffrey Thompson , Enterprise Systems for Management, Pearson Publication, 2nd Edition, ISBN-13: 9780132145763

**Web Links:**

1. NPTEL Course on Enterprise Systems
2. [SAP Official Learning Hub](#)

**Relevant cases have to be discussed in each unit and in examination case study is compulsory from any unit.**

## DESIGN THINKING AND INNOVATION

**Course Code: 2507BA38**

<b>L</b>	<b>T</b>	<b>P</b>	<b>C</b>
<b>2</b>			<b>2</b>

**Course Outcomes:**

**At the end of the Course, Student will be able to:**

- CO1:** Explain the core concepts and historical evolution of Design Thinking.
- CO2:** Apply empathy research methods to gather user insights and create problem statements and journey maps.
- CO3:** Analyze ideation techniques and develop prototypes using various tools.
- CO4:** Evaluate user feedback and implement iterative design improvements.
- CO5:** Examine the principles and processes of innovation and differentiate between types of innovation.

**Mapping of Course Outcomes with Program Outcomes:**

<b>CO / PO</b>	<b>PO1</b>	<b>PO2</b>	<b>PO3</b>	<b>PO4</b>	<b>PO5</b>	<b>PO6</b>	<b>PO7</b>	<b>PO8</b>	<b>PO9</b>	<b>PO10</b>	<b>PO11</b>
<b>CO1</b>	3	2	2	2	2	2	2	1	1	2	1
<b>CO2</b>	2	3	2	2	2	2	3	2	3	2	1
<b>CO3</b>	2	3	2	3	2	3	3	2	3	2	1
<b>CO4</b>	2	2	2	2	2	3	2	1	2	2	1
<b>CO5</b>	3	2	3	2	2	2	3	2	2	2	1

**Mapping of Course Outcomes with Program Specific Outcomes:**

<b>CO / PSO</b>	<b>PSO1</b>	<b>PSO2</b>	<b>PSO3</b>
<b>CO1</b>	2	2	2
<b>CO2</b>	2	2	3
<b>CO3</b>	2	2	3
<b>CO4</b>	2	2	2
<b>CO5</b>	2	2	3

**UNIT I:**

**Introduction to Design Thinking:** Covers innovation, creative thinking, problem-solving approaches, and the Design Thinking process—Empathize, Define, Ideate, Prototype, and Implement— using examples like Apple, Netflix, and Airbnb.

**UNIT II:**

**Empathy and Problem Understanding:** Focuses on developing empathy using design tools, observing users, understanding uniqueness, and identifying complex "wicked problems" around us.

**UNIT III:**

**Ideation and Defining Solutions:** Introduces brainstorming, systems thinking, and mapping customer experiences to generate creative solutions to defined problems.

**UNIT IV:**

**Prototyping and Implementation:** Covers rapid prototyping, testing ideas, and planning implementation, with emphasis on converting ideas into practical solutions.

**UNIT V:**

**Feedback and Redesign:** Focuses on gathering user feedback, improving design based on experience, and presenting final innovative solutions.

**Text Books**

1. Gavin Ambrose, Paul Harris, BasicsDesign-8: DesignThinking,illustrated, reprint, AVA Publishing, ISBN-10:2940411174, ISBN-13: 978-2940411177.
2. Christian Müller-Roterberg, Handbook of Design Thinking, Kindle Direct Publishing, ISBN: 978-1790435371.

**Reference Books:**

1. CSG Krishnamacharyulu & Lalitha R, Innovation Management, Himalaya Publishing House.ISBN-10:9350979209, ISBN-13: 978-9350979204.
2. Vinnie Jauhari, Sudanshu Bhushan, Innovation Management, Oxford Higher Education.ISBN-10: 0198080980, ISBN-13: 978-0198080985.

**Web Links:**

1. [https://onlinecourses.nptel.ac.in/noc22\\_mg32/preview](https://onlinecourses.nptel.ac.in/noc22_mg32/preview)
2. [https://onlinecourses.swayam2.ac.in/imb23\\_mg65/preview](https://onlinecourses.swayam2.ac.in/imb23_mg65/preview)

**Relevant cases have to be discussed in each unit and in examination case study is compulsory from any unit.**

## CORPORATE GOVERNANCE

<b>Course Code: 2507BA04</b>	<b>L</b>	<b>T</b>	<b>P</b>	<b>C</b>
	<b>2</b>			<b>2</b>

### Course Outcomes:

**At the end of the Course, Student will be able to:**

- CO1:** Explain the concept, importance, and principles of corporate governance.
- CO2:** Analyze the role of board structures and committees in corporate governance.
- CO3:** Evaluate corporate governance practices in India and globally.
- CO4:** Understand the role of ethics, CSR, and sustainability in corporate governance.
- CO5:** Examine corporate frauds and governance failures with case studies.

### Mapping of Course Outcomes with Program Outcomes:

CO / PO	PO1	PO2	PO3	PO4	PO5	PO6	PO7	PO8	PO9	PO10	PO11
<b>CO1</b>	3	2	2	1	2	3	2	1	2	1	2
<b>CO2</b>	3	3	2	1	2	3	2	2	1	1	2
<b>CO3</b>	3	3	2	2	3	3	2	2	1	1	2
<b>CO4</b>	2	2	2	1	3	3	2	3	1	2	2
<b>CO5</b>	2	3	2	2	3	3	2	2	2	1	2

### Mapping of Course Outcomes with Program Specific Outcomes:

CO / PSO	PSO1	PSO2	PSO3
<b>CO1</b>	2	1	2
<b>CO2</b>	3	2	2
<b>CO3</b>	3	3	2
<b>CO4</b>	2	2	2
<b>CO5</b>	3	2	3

### UNIT I:

**Introduction to Corporate Governance:** Meaning, significance, and principles of Corporate Governance, relationship between management and corporate governance, theories of Corporate Governance: Agency Theory, Stewardship Theory, Stakeholder Theory, one-tier and two-tier board structures.

### UNIT II:

**Role of Stakeholders in Corporate Governance:** Board composition: Executive, Non-Executive, and Independent Directors, role and responsibilities of the Board and its committees, insider trading and shareholder activism, class action suits, whistleblowing mechanism, and CSR's role in governance.

### UNIT III:

**Global Corporate Failures and International Codes:** Case studies: Maxwell (UK), Enron (USA), Sir Adrian Cadbury Committee Report (1992), Sarbanes-Oxley (SOX) Act 2002, OECD Principles of Corporate Governance.

### UNIT IV:

**Corporate Governance in India:** Kumar Mangalam Birla Committee (1999), NR Narayana Murthy Committee (2005), and Uday Kotak Committee (2017), regulatory framework: Companies Act, 2013, and

SEBI's LODR (2015), governance failures in India: Satyam Computer Services, Kingfisher Airlines, PNB Heist, ICICI Bank.

#### **UNIT V:**

**Analysis of Corporate Failures and Governance Problems:** Common governance issues in corporate failures in India and abroad, lessons from corporate governance failures, analysis of preventive measures and solutions.

#### **Text Books:**

1. Bob Tricker, Corporate Governance: Principles, Policies, and Practices (2025), Oxford University Press, 5th Edition, ISBN-13: 978-0192885456
2. Jason Harris, Principles of Contemporary Corporate Governance, (2024), Cambridge University Press, ISBN-13: 978-1009287388

#### **Reference Books:**

1. Salvatore Esposito De Falco, Corporate Governance: Theories, Actors, and Control Systems in the Age of New Capitalism, (2024), Palgrave Macmillan Publication ISBN-13: 978-3-031-74091-6
2. Shital Jhunjhunwala, Corporate Governance: Creating Value for Stakeholder (2024), Palgrave Macmillan Singapore, ISBN-13: 978-981-99-2771-5

#### **Web Links:**

1. <https://nptel.ac.in/courses/110/106/110106145/>
2. [https://www.youtube.com/watch?v=7TjdC\\_zUG8k](https://www.youtube.com/watch?v=7TjdC_zUG8k)

**Relevant cases have to be discussed in each unit, and in examination, case study is compulsory from any unit.**

**MANDATORY COURSES  
EMPLOYABILITY SKILLS-1**

**Course Code: 2507AC01**

**L T P C**  
**2**

**Course Outcomes:**

**At the end of the Course, Student will be able to:**

- CO1:** Apply fundamental arithmetic concepts such as number systems, LCM & HCF, ratio & proportion, and averages to solve quantitative problems efficiently.
- CO2:** Analyze number and letter series to identify logical patterns and predict subsequent elements.
- CO3:** Select the option by evaluating relationships in analogy-based problems and detecting inconsistencies in logical sequences
- CO4:** Demonstrate effective verbal communication skills by using appropriate parts of speech and tone in various interpersonal and professional contexts.

**Mapping of Course Outcomes with Program Outcomes:**

CO / PO	PO1	PO2	PO3	PO4	PO5	PO6	PO7	PO8	PO9	PO10	PO11
<b>CO1</b>	3	2	–	–	–	–	–	–	–	–	2
<b>CO2</b>	–	3	2	–	–	–	–	–	–	–	2
<b>CO3</b>	–	3	3	–	1	–	–	–	–	–	2
<b>CO4</b>	–	–	–	3	–	2	–	2	–	3	2

**Mapping of Course Outcomes with Program Specific Outcomes:**

CO \ PSO	PSO1	PSO2	PSO3
<b>CO1</b>	2	2	–
<b>CO2</b>	2	3	–
<b>CO3</b>	–	2	3
<b>CO4</b>	–	–	3

**Aptitude:**

Number System, LCM & HCF, Ratio and Proportion, Averages

**Reasoning:**

Number Series, Letter Series, Number Analogy, Letter Analogy, Odd Man Out, Logical Sequence of Words.

**Verbal:**

Introduction to soft skills, how to improve communication? Parts of Speech, Mind your language towards better English, Vocabulary Expansion

**Text Books:**

1. Dr. R. S. Aggarwal, Quantitative Aptitude for Competitive Examinations , S. Chand Publishing, ISBN: 978-9352534029
2. Dr. R. S. Aggarwal, A Modern Approach to Verbal and Non-Verbal Reasoning, S. Chand

Publishing, ISBN: 978-9352832163

**Reference Books:**

1. Dr. R. S. Aggarwal, Vikas Aggarwal, Quick Learning Objective General English, S. Chand Publishing, ISBN: 978-9352837564
2. Abhijit Guha, Quantitative Aptitude for Competitive Examinations, McGraw-Hill Education, ISBN: 978-9353160180
3. M. K. Pandey, Analytical Reasoning, Arihant Publications, ISBN: 978- 9350947982

**Web Links:**

1. [www.indiabix.com](http://www.indiabix.com)
2. [www.bankersadda.com](http://www.bankersadda.com)

## EMPLOYABILITY SKILLS- II

**L T P C**

**Course Code: 2507AC02**

**2**

### Course Outcomes:

**At the end of the Course, Student will be able to:**

- CO1:** Apply percentage, profit & loss, and partnership concepts to solve real-world quantitative problems.
- CO2:** Analyze age-related problems to develop logical problem-solving strategies.
- CO3:** Evaluate logical reasoning questions including ranking, directions, and alphabet tests for accurate decision-making.
- CO4:** Solve pattern-based problems in coding and decoding to enhance analytical skills.
- CO5** Demonstrate effective written communication using correct grammar and structured presentation techniques

### Mapping of Course Outcomes with Program Outcomes:

CO / PO	PO1	PO2	PO3	PO4	PO5	PO6	PO7	PO8	PO9	PO10	PO11
<b>CO1</b>	3	2	–	–	–	–	–	–	–	–	2
<b>CO2</b>	–	3	2	–	–	–	–	–	–	–	2
<b>CO3</b>	–	3	3	–	1	–	–	–	–	–	2
<b>CO4</b>	–	2	3	–	–	–	–	–	–	–	2
<b>CO5</b>	–	–	–	3	–	2	–	2	–	3	2

### Mapping of Course Outcomes with Program Specific Outcomes:

CO \ PSO	PSO1	PSO2	PSO3
<b>CO1</b>	2	2	–
<b>CO2</b>	2	3	–
<b>CO3</b>	–	2	3
<b>CO4</b>	–	2	2
<b>CO5</b>	–	–	3

#### Aptitude:

Problems on Ages, Partnership, Percentages, Profit and Loss

#### Reasoning:

Coding and Decoding, Ranking Test, Alphabet Test, Direction Test

#### Verbal:

Written communication skill practice, Grammatical use, Concept of 4 step method for presentation, Present Tense

#### Text Books:

1. Dr. R. S. Aggarwal, Quantitative Aptitude for Competitive Examinations, S. Chand Publishing, ISBN: 978-9352534029
2. Dr. R. S. Aggarwal, A Modern Approach to Verbal and Non-Verbal Reasoning, Publication: S. Chand Publishing, ISBN: 978-9352832163

#### Reference Books:

1. Dr. R. S. Aggarwal, Vikas Aggarwal, Quick Learning Objective General English , S.Chand Publishing, ISBN: 978-9352837564
2. Abhijit Guha, Quantitative Aptitude for Competitive Examinations, McGraw Hill Education, ISBN: 978-9353160180
3. M. K. Pandey, Analytical Reasoning , Arihant Publications, ISBN: 978-9350947982

**Web Links:**

1. [www.indiabix.com](http://www.indiabix.com)
2. [www.bankersadda.com](http://www.bankersadda.com)

### EMPLOYABILITY SKILLS-III

Course Code: 2507AC03

L T P C  
2

#### Course Outcomes:

At the end of the Course, Student will be able to:

- CO1:** Solve financial and quantitative aptitude problems using concepts of simple and compound interest.
- CO2:** Apply logical time-work frameworks to solve real-time problems related to work efficiency and pipe systems.
- CO3:** Analyze and interpret problems related to blood relations, clocks, calendars, and coded inequalities.
- CO4:** Evaluate spatial and logical reasoning through cubes, dice, and symbolic interpretation problems.
- CO5** Demonstrate effective communication using correct grammar, and participate actively in discussions and comprehension activities.

#### Mapping of Course Outcomes with Program Outcomes:

CO / PO	PO1	PO2	PO3	PO4	PO5	PO6	PO7	PO8	PO9	PO10	PO11
CO1	3	2	–	–	–	–	–	–	–	–	2
CO2	2	3	2	–	–	–	–	–	–	–	2
CO3	–	3	3	–	1	–	–	–	–	–	2
CO4	–	2	3	–	–	–	–	–	–	–	2
CO5	–	–	–	3	–	2	–	2	–	3	2

#### Mapping of Course Outcomes with Program Specific Outcomes:

CO \ PSO	PSO1	PSO2	PSO3
CO1	2	2	–
CO2	2	3	–
CO3	–	2	3
CO4	–	2	2
CO5	–	–	3

#### Aptitude:

Simple Interest, Compound Interest, Time and Work, Pipes and Cisterns

#### Reasoning:

Blood Relations, Calendar, Clocks, Cubes and Dice, Coded Inequalities

#### Verbal:

Grammar in use, Group discussion, Reading Comprehension, Past Tense, Future Tense

#### Text Books:

1. Dr. R. S. Aggarwal, Quantitative Aptitude for Competitive Examinations, S. Chand Publishing, ISBN: 978-9352534029
2. Dr.R.S.Aggarwal, A Modern Approach to Verbal and Non-Verbal Reasoning, S. Chand Publishing, ISBN: 978-9352832163

#### Reference Books:

1. Dr. R. S. Aggarwal, Vikas Aggarwal, Quick Learning Objective General English ,S. Chand

- Publishing, ISBN: 978-9352837564
2. AbhijitGuha, Quantitative Aptitude for Competitive Examinations, McGrawHill Education, ISBN: 978-9353160180
  3. M.K.Pandey, Analytical Reasoning Arihant Publications, ISBN: 978-9350947982

**Web Links:**

1. [www.indiabix.com](http://www.indiabix.com)
2. [www.bankersadda.com](http://www.bankersadda.com)

## EMPLOYABILITY SKILLS-IV

**Course Code: 2507AC04**

**L T P C**  
**2**

### Course Outcomes:

**At the end of the Course, Student will be able to:**

- CO1:** Apply concepts of time, speed, distance, trains, boats and streams to solve motion-related aptitude problems.
- CO2:** Solve mensuration problems involving surface area and volume in real-world contexts.
- CO3:** Analyze logical reasoning questions involving Venn diagrams and syllogisms to make valid conclusions.
- CO4:** Interpret seating arrangements and solve non-verbal reasoning questions involving patterns and spatial reasoning.

### Mapping of Course Outcomes with Program Outcomes:

CO / PO	PO1	PO2	PO3	PO4	PO5	PO6	PO7	PO8	PO9	PO10	PO11
<b>CO1</b>	3	2	–	–	–	–	–	–	–	–	2
<b>CO2</b>	3	2	–	–	–	–	–	–	–	–	2
<b>CO3</b>	–	3	3	–	1	–	–	–	–	–	2
<b>CO4</b>	–	2	3	–	–	–	–	–	–	–	2

### Mapping of Course Outcomes with Program Specific Outcomes:

CO \ PSO	PSO1	PSO2	PSO3
<b>CO1</b>	2	2	–
<b>CO2</b>	2	2	–
<b>CO3</b>	–	2	3
<b>CO4</b>	–	2	2

### Aptitude:

Time, Speed and Distance, Problems on Trains, Boats and Streams, Mensuration-I, Mensuration - II

### Reasoning:

Venn Diagrams, Syllogisms, Non - Verbal Reasoning, Seating Arrangement

### Verbal

Grammatical use, Self-introduction, Letters, E-Mail & Report writing, Error correction, Effective Communication

### Text Books:

1. Dr.R.S.Aggarwal, Quantitative Aptitude, SChand
2. Dr.R.S.Aggarwal, A Modern Approach to Verbal and Non-Verbal Reasoning, Quick Learning
3. Dr.R.S.Aggarwal, , Objective General English, SChand

### Reference Books:

1. AbhijitGuha, Quantitative Aptitude, McGraw-Hill Publications.
2. Jaikishanand Premkishan, Analytical Reasoning, Arihant Publications.

3. R.S.Dhillon, A New Approach to Objective English, DGPPublications.

**Web Links:**

1. [www.indiabix.com](http://www.indiabix.com)
2. [www.bankersadda.com](http://www.bankersadda.com)