

PROGRAM CURRICULUM

(Applicable for the batches admitted from A.Y 2025-26)

THREE YEAR U.G PROGRAM

BACHELOR OF BUSINESS ADMINISTRATION

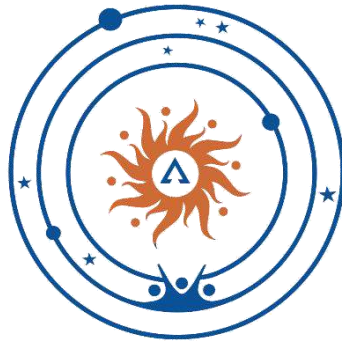

A D I T Y A
U N I V E R S I T Y

Aditya Nagar, ADB Road, Surampalem, Andhra Pradesh

VISION & MISSION OF THE UNIVERSITY

VISION

To be a globally recognized University through excellence in Education, Innovation, and Sustainable Growth

MISSION

Deliver collaborative education to prepare students for global challenges through

1. Transformative learning.
2. Vibrant research ecosystem.
3. Sustainable and inclusive community

VISION & MISSION OF THE SCHOOL OF BUSINESS

VISION

To be a world-class business school advancing academic excellence, innovation, and global talent to develop responsible leaders shaping an inclusive and sustainable future

MISSION

M1: Deliver transformative business education that blends academic rigor with real-world relevance and ethical grounding.

M2: Nurture globally competent, entrepreneurial leaders through innovation, research, and interdisciplinary learning.

M3: Champion sustainability, social impact, and inclusive growth through collaborative industry and community Engagement

PROGRAM OUTCOMES (POs)

After successful completion of the program,

- PO1: Proficiency in Business Fundamentals:** Graduates will showcase a thorough grasp of essential business concepts, models, and practices spanning multiple functional areas of management.
- PO2: Competence in Solving Business Challenges:** Graduates will effectively diagnose and resolve complex business issues by applying research tools, data interpretation, and strategic decision-making approaches.
- PO3: Logical and Analytical Reasoning:** Graduates will demonstrate the capacity to critically assess business scenarios, apply structured thinking, and arrive at reasoned, evidence-based conclusions.
- PO4: Strong Communication Skills:** Graduates will be able to articulate ideas clearly and confidently through both written and spoken communication, suitable for diverse professional contexts including presentations, reports, and negotiations.
- PO5: Legal Awareness and Ethical Integrity:** Graduates will understand and apply business laws, uphold ethical standards in decision-making, and recognize the importance of corporate governance and compliance.
- PO6: Leadership and Team Engagement:** Graduates will develop key leadership attributes, including the ability to guide, influence, and collaborate with teams while embracing adaptability and shared problem-solving.
- PO7: Entrepreneurial Orientation:** Graduates will embody entrepreneurial thinking, demonstrating originality, proactive innovation, and the ability to pursue and develop new business ventures or opportunities.
- PO8: Commitment to Human Values:** Graduates will integrate core human values such as honesty, empathy, harmony, and scientific curiosity into their personal and professional conduct, promoting ethical and socially conscious leadership.
- PO9: Digital and Technological Literacy:** Graduates will possess the ability to leverage digital tools, business technologies, and analytics platforms to enhance decision-making and organizational efficiency.
- PO10: Teamwork and Global Business Dynamics:** Graduates will work productively within diverse and cross-cultural teams, contributing effectively to collective goals through cooperation, shared responsibility, and mutual respect, while demonstrating awareness of international business trends, cultural nuances, and the economic impact of globalization on business practices.
- PO11: Lifelong Learning Orientation:** Graduates will exhibit a proactive attitude toward continuous learning, professional growth, and staying aligned with evolving industry practices and innovations.

PROGRAM SPECIFIC OUTCOMES (PSOs)

After successful completion of the program,

- PSO1: Foundational Business Acumen:** Graduates will demonstrate conceptual clarity and foundational knowledge in key business areas such as marketing, finance, HR, and operations, preparing them for entry-level corporate roles or higher studies.
- PSO2: Industry Readiness and Employability Skills:** Graduates will exhibit practical business competencies including problem-solving, team collaboration, communication, and adaptability—ensuring their readiness for corporate internships, placements, or entrepreneurial pursuits.
- PSO3: Ethical and Digital Citizenship:** Graduates will uphold ethical business practices and leverage digital tools responsibly, contributing meaningfully to organizations and society in a globally interconnected world.

PROGRAM EDUCATIONAL OBJECTIVES (PEOs)

After successful completion, this program will support

- PEO 1: Strong Foundation in Business Disciplines:** To equip students with comprehensive knowledge across essential business domains such as accounting, finance, marketing, operations, and management, fostering a robust understanding of core principles that drive business success.
- PEO 2: Development of Analytical and Problem-Solving Skills:** To build students' capacity for critical thinking and logical analysis, enabling them to address complex business challenges through informed decision-making and data-driven solutions.
- PEO 3: Mastery in Communication:** To strengthen students' written, verbal, and interpersonal communication skills, preparing them to articulate ideas clearly, craft professional business documents, and deliver impactful presentations.
- PEO 4: Fostering Collaboration and Leadership:** To instill a strong appreciation for teamwork and cooperative problem-solving, while also nurturing leadership abilities that empower students to effectively manage group dynamics and drive collective success.
- PEO 5: Encouraging Innovation and Entrepreneurial Thinking:** To inspire a spirit of innovation and cultivate an entrepreneurial outlook, encouraging students to think creatively, embrace risk, and recognize emerging opportunities in the business landscape.
- PEO 6: Commitment to Lifelong Learning and Growth:** To promote an enduring commitment to personal and professional development by encouraging students to remain agile, pursue advanced learning, and adapt continuously in a fast-changing business environment.

Bachelor of Business Administration
Program Curriculum-2025

Credit Division:

S. No	Category of Courses	Credits
1	Program Core Courses (PCC)	60
2	Program Elective Courses (PEC)	12
3	Ability Enhancement Courses (AEC)	11
4	Multi-Disciplinary Course (MDC)	05
5	Value Added Courses (VAC)	12
6	Skill Enhancement Courses (SEC)	12
7	Summer Internship (SI)	04
8	Capstone Project (CPROJ)	04
10	Mandatory courses (MC)	0
Total Credits		120

FC- Fundamental Courses

IC- Intermediate Level Courses

AC- Advanced Courses

Program Core Courses (PCC)											
Course Code	Course Title	Level	L	T	P	C	CIE	SEE	Total	Pre-requisite	
2505BB59	Principles and Practices of Management	FC	2		1	3	50	50	100	-	
2505BB49	Financial Accounting	FC	2	1		3	50	50	100	-	
2505BB44	Business Statistics and Logic	FC	2	1		3	50	50	100	-	
2505BB57	Micro economics	FC	2		1	3	50	50	100	-	
2505BB08	Human Behavior and Organization	IC	2		1	3	50	50	100	PPM	
2505BB55	Marketing Management	FC	2		1	3	50	50	100	-	
2505BB12	Macro Economics	IC	2		1	3	50	50	100	MiE	
2505BB04	Cost and Management Accounting	IC	2	1		3	50	50	100	FA	
2505BB54	Legal and Ethical Issues in Business	FC	2		1	3	50	50	100	-	
2505BB09	Human Resource Management	IC	2		1	3	50	50	100	HBO	
2505BB43	Business Environment and Public Policy	FC	2		1	3	50	50	100	-	
2505BB47	Entrepreneurship and Start up Eco system	FC	2	1		3	50	50	100	-	
2505BB58	Operations Management	FC	2		1	3	50	50	100	-	
2505BB07	Financial Management	IC	2	1		3	50	50	100	FA	
2505BB44	Business Research Methodology	FC	2	1		3	50	50	100	-	
2505BB60	Strategic Management	FC	2		1	3	50	50	100	-	
2505BB11	Logistics and Supply chain Management	IC	2		1	3	50	50	100	MM	
2505BB52	Intellectual Property Rights	FC	2		1	3	50	50	100	-	
2505BB32	Project Management	AC	2		1	3	50	50	100	OM	
2505BB18	Business Taxation	AC	2	1		3	50	50	100	FA	
	Total					60					

Program Elective Courses (PEC)

Program Elective Courses	Finance	Marketing	HR	Logistics and Supply Chain	Digital Transformation and Innovation
PEC-I	Financial Markets Products and Services	Sales Management	Employee Life Cycle Management	Reverse Logistics	Data Mining for Business Decisions
PEC-II	Business Analysis and Valuation	Retail Marketing	Cross Culture HRM	International Logistics Management	Managing Software Projects
PEC-III	Financial Planning	International Marketing	Talent Acquisition and Management	Quality Management and Business Process Improvement	Web Designing
PEC-IV	Sustainable Finance	Rural Marketing	HR Analytics	Management Decision Models	Business Analytics

Finance (FIN)											
Course Code	Course Title	Level	L	T	P	C	CIE	SEE	Total	Pre-requisite	
2505BB25	Financial Markets Products and Services	AC	2		1	3	50	50	100	FM	
2505BB16	Business Analysis and Valuation	AC	2		1	3	50	50	100		
2505BB26	Financial Planning	AC	2		1	3	50	50	100		
2505BB39	Sustainable Finance	AC	2		1	3	50	50	100		

Marketing (MKTG)											
Course Code	Course Title	Level	L	T	P	C	CIE	SEE	Total	Pre-requisite	
2505BB37	Sales Management	AC	2		1	3	50	50	100	MM	
2505BB34	Retail Marketing	AC	2		1	3	50	50	100		
2505BB29	International Marketing	AC	2		1	3	50	50	100		
2505BB36	Rural Marketing	AC	2		1	3	50	50	100		

Human Resource (HR)											
Course Code	Course Title	Level	L	T	P	C	CIE	SEE	Total	Pre-requisite	
2505BB24	Employee Life Cycle Management	AC	2		1	3	50	50	100	HRM	
2505BB21	Cross Culture HRM	AC	2		1	3	50	50	100		
2505BB40	Talent Acquisition and Management	AC	2		1	3	50	50	100		
2505BB27	HR Analytics	AC	2		1	3	50	50	100		

Logistics and Supply Chain (LSC)											
Course Code	Course Title	Level	L	T	P	C	CIE	SEE	Total	Pre-requisite	
2505BB35	Reverse Logistics	AC	2		1	3	50	50	100	MM	
2505BB28	International Logistics Management	AC	2		1	3	50	50	100		
2505BB33	Quality Management and Business Process Improvement	AC	2		1	3	50	50	100		
2505BB30	Management Decision Models	AC	2		1	3	50	50	100		

Digital Transformation and Innovation (DTI)											
Course Code	Course Title	Level	L	T	P	C	CIE	SEE	Total	Pre-requisite	
2505BB22	Data Mining for Business Decisions	AC	2		1	3	50	50	100	ITS	
2505BB31	Managing Software Projects	AC	2		1	3	50	50	100		
2505BB41	Web Designing	AC	2		1	3	50	50	100		
2505BB17	Business Analytics	AC	2		1	3	50	50	100		

Ability Enhancement Courses (AEC)										
Course Code	Course Title	Level	L	T	P	C	CIE	SEE	Total	Pre-requisite
2505BB42	Business Communication-1	FC	2	1		3	50	50	100	-
2505BB02	Business Communication-II	IC	2	1		3	50	50	100	BC-I
2505BB50	Fundamental Cognitive Skills for Managers	FC			1	1	100	-	-	-
2505BB01	Advanced Cognitive skills for Managers	IC			1	1	100	-	-	FCSM
2505BB23	Employability Skills V	AC				1	100	-	-	ES-IV
2505BB38	Student Activity Based Learning	AC				2	-	-	-	-

Multi-Disciplinary Course (MDC)										
Course Code	Course Title	Level	L	T	P	C	CIE	SEE	Total	Pre-requisite
2505BB53	IT & AI Skills	FC	1		2	3	100	-	100	-
2505BB56	Media Literacy and Critical Thinking	FC	2			2	50	50	100	-

Value Added Courses (VAC)										
Course Code	Course Title	Level	L	T	P	C	CIE	SEE	Total	Pre-requisite
2505BB48	Environmental Science and Sustainability	FC	2			2	50	50	100	-
2505BB51	Indian constitution	FC	2			2	50	50	100	-
2505BB14	Public Health and Management	FC	2			2	50	50	100	-
2505BB03	Community service Project	FC			3	3	100	-	100	-
2505BB10	International Business	IC	2		1	3	50	50	100	BEPP

Skill Enhancement Courses (SEC)										
Course Code	Course Title	Level	L	T	P	C	CIE	SEE	Total	Pre-requisite
2505BB05	Emerging Technologies and Applications	IC	2			2	50	50	100	IT&AIS
2505BB13	Management Information System	AC	2		1	3	50	50	100	ETA
2505BB06	Enterprise System and Platforms	IC	2		1	3	50	50	100	IT&AI
2505BB46	Design Thinking and Innovation	FC	2			2	50	50	100	-
2505BB20	Corporate Governance	AC	2			2	50	50	100	BEPP

Summer Internship (SI)										
Course Code	Course Title	Level	L	T	P	C	CIE	SEE	Total	Pre-requisite
2505BB15	Summer Internship	IC			4	4	100	-	100	-

Capstone Project (CPROJ)										
Course Code	Course Title	Level	L	T	P	C	CIE	SEE	Total	Pre-requisite
2505BB19	Capstone Project	AC			4	4	50	50	100	-

Mandatory Courses (MC)										
Course Code	Course Title	Level	L	T	P	C	CIE	SEE	Total	Pre-requisite
2505AC01	Employability Skills-I	FC	2				100	-	100	-
2505AC02	Employability Skills-II	FC	2				100	-	100	-
2505AC03	Employability Skills-III	IC	2				100	-	100	ES-II
2505AC04	Employability Skills-IV	IC	2				100	-	100	ES-III

2025 BBA CURRICULUM
Pre - Requisite Flow Chart

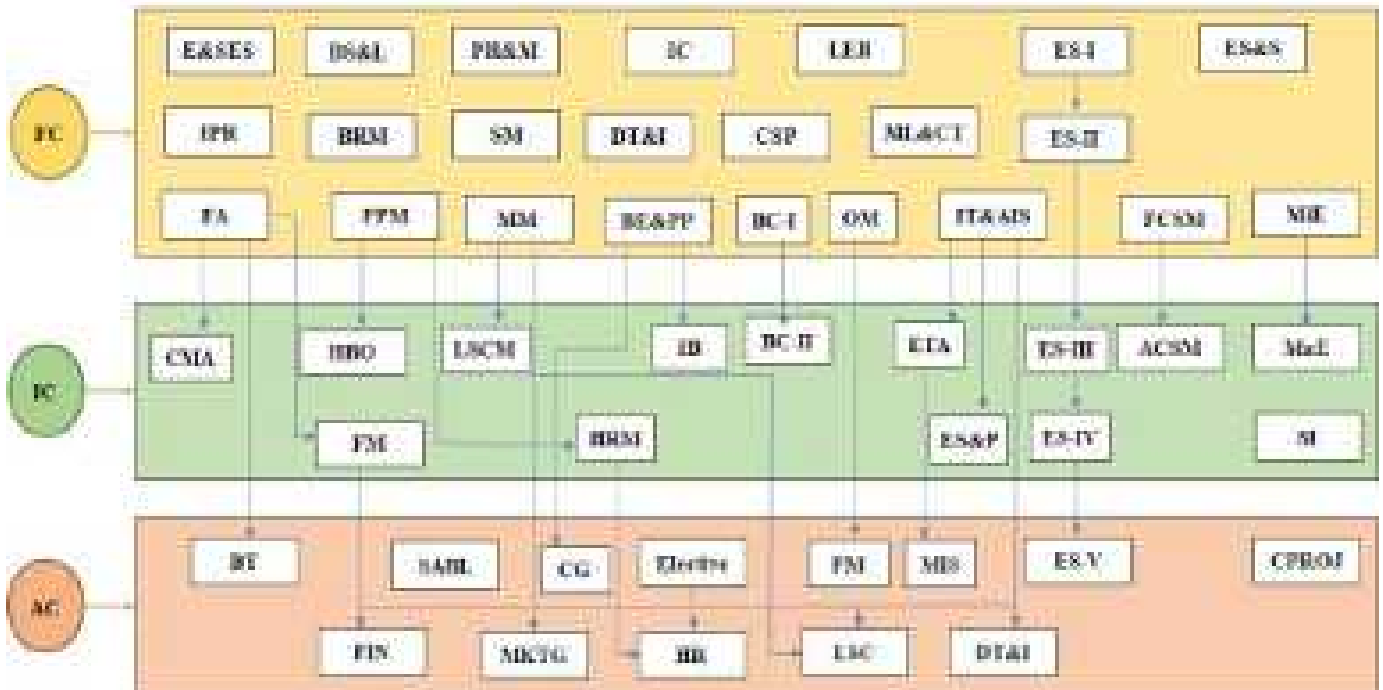

Fundamental Courses	
PPM	Principles and Practices of Management
FA	Financial Accounting
BS&L	Business Statistics and Logic
MiE	Micro economics
MM	Marketing Management
L&EIB	Legal and Ethical Issues in Business
BEPP	Business Environment and Public Policy
ES&ES	Entrepreneurship and Start up Eco system
OM	Operations Management
BRM	Business Research Methodology
SM	Strategic Management
IPR	Intellectual Property Rights
BC-1	Business Communication-1
FCSM	Fundamental Cognitive Skills for Managers
IT&AI	IT & AI Skills
ML&CT	Media Literacy and Critical Thinking
ES&S	Environmental Science and Sustainability
IC	Indian constitution
PH&M	Public Health and Management
CSP	Community service Project
DT&I	Design Thinking and Innovation
ES-1	Employability Skills-I
ES-II	Employability Skills-II

Intermediate Level Courses	
HBO	Human Behavior and Organization
MaE	Macro Economics
CMA	Cost and Management Accounting
HRM	Human Resource Management
FM	Financial Management
L&SCM	Logistics and Supply Chain Management
BC-II	Business Communication-II
ACSM	Advanced Cognitive skills for Managers
IB	International Business
ET&A	Emerging Technologies and Applications
ER&P	Enterprise System and Platforms
SI	Summer Internship
ES-III	Employability Skills-III
ES-IV	Employability Skills-IV

Advanced Courses	
PM	Project Management
BT	Business Taxation
ES-V	Employability Skills V
SCBL	Student Activity Based Learning
MIS	Management Information System
CG	Corporate Governance
CPROJ	Capstone Project
Program Elective Courses	
FIN	Finance
MKTG	Marketing
HR	Human Resource
LSC	Logistics and Supply Chain
DTI	Digital Transformation and Innovation

Suggestive Semester-wise Curriculum

SEMESTER-I									
Course Code	Course Title	Level	Course Category	Credits				Total Hours	Pre requisite
				L	T	P	Total		
2505BB59	Principles and Practices of Management	FC	PCC	2		1	3	4	-
2505BB49	Financial Accounting	FC	PCC	2	1		3	3	-
2505BB44	Business Statistics and Logic	FC	PCC	2	1		3	3	-
2505BB57	Micro economics	FC	PCC	2		1	3	4	-
2505BB42	Business Communication-1	FC	AEC	2	1		3	3	-
2505BB50	Fundamental Cognitive Skills for Managers	FC	AEC			1	1	2	-
2505BB53	IT & AI Skills	FC	MDC	1		2	3	5	-
2505BB48	Environmental Science and Sustainability	FC	VAC	2			2	2	-
2505AC01	Employability Skills I	FC	MC	2				3	-
Total							21	29	

SEMESTER-II									
Course Code	Course Title	Level	Course Category	Credits				Total Hours	Pre requisite
				L	T	P	Total		
2505BB08	Human Behavior and Organization	IC	PCC	2		1	3	4	PPM
2505BB55	Marketing Management	FC	PCC	2		1	3	4	-
2505BB12	Macro Economics	IC	PCC	2		1	3	4	MiE
2505BB02	Business Communication II	IC	AEC	2	1		3	3	BC-I
2505BB01	Advanced Cognitive Skills for Managers	IC	AEC			1	1	2	FCSM
2505BB51	Indian constitution	FC	VAC	2			2	2	-
2505BB05	Emerging Technologies and Applications	IC	SEC	2			2	2	IT&AI
2505BB56	Media Literacy and Critical Thinking	FC	MDC	2			2	2	-
2505AC02	Employability Skills II	FC	MC	2				3	-
Total							19	26	

SEMESTER-III									
Course Code	Course Title	Level	Course Category	Credits				Total Hours	Pre requisite
				L	T	P	Total		
2505BB04	Cost and Management Accounting	IC	PCC	2	1		3	3	FA
2505BB54	Legal and Ethical Issues in Business	IC	PCC	2		1	3	4	-
2505BB09	Human Resource Management	IC	PCC	2		1	3	4	HBO
2505BB43	Business Environment and Public Policy	FC	PCC	2		1	3	4	-
2505BB13	Management Information System	AC	SEC	2		1	3	4	ETA
2505BB14	Public Health and Management	FC	VAC	2			2	2	-
2505BB03	Community service Project	FC	VAC			3	3	-	-
2505AC03	Employability Skills III	IC	MC	2				3	ES-II
Total							20	24	

SEMESTER-IV									
Course Code	Course Title	Level	Course Category	Credits				Total Hours	Pre requisite
				L	T	P	Total		
2505BB47	Entrepreneurship and Start up Eco system	FC	PCC	2	1		3	3	-
2505BB58	Operations Management	FC	PCC	2		1	3	4	-
2505BB07	Financial Management	IC	PCC	2	1		3	3	FA
2505BB44	Business Research Methodology	FC	PCC	2	1		3	3	-
2505BB10	International Business	IC	VAC	2		1	3	4	BEPP
2505BB06	Enterprise System and Platforms	IC	SEC	2		1	3	4	IT&AI
2505BB46	Design Thinking and Innovation	FC	SEC	2			2	3	-
2505AC03	Employability Skills IV	IC	MC	2				3	ES-III
Total							20	27	

SEMESTER-V									
Course Code	Course Title	Level	Course Category	Credits				Total Hours	Pre requisite
				L	T	P	Total		
2505BB60	Strategic Management	FC	PCC	2		1	3	4	-
2505BB11	Logistics and Supply chain Management	IC	PCC	2		1	3	4	MM
2505BB52	Intellectual Property Rights	FC	PCC	2		1	3	4	-
----	Program Elective Course-1	AC	PEC	2		1	3	4	-
----	Program Elective Course –II	AC	PEC	2		1	3	4	-
2505BB15	Summer Internship	IC	SI			4	4	-	-
	Employability Skills V	AC	AEC				1	3	ES-IV
Total							20	23	

SEMESTER-VI									
Course Code	Course Title	Level	Course Category	Credits				Total Hours	Pre requisite
				L	T	P	Total		
2505BB32	Project Management	AC	PCC	2		1	3	4	OM
2505BB18	Business Taxation	AC	PCC	2	1		3	3	FA
----	Program Elective Course –III	AC	PEC	2		1	3	4	-
----	Program Elective Course –IV	AC	PEC	2		1	3	4	-
2505BB20	Corporate Governance	AC	SEC	2			2	2	BEPP
2505BB19	Capstone Project	AC	CPROJ			4	4	-	-
2505BB38	Student Activity Based Learning	AC	AEC				2	-	-
Total							20	17	

PROGRAM CORE COURSES
PRINCIPLES AND PRACTICES OF MANAGEMENT

Course Code: 2505BB59 **L T P C**
2 1 3

Course Outcomes:

At the end of the Course, Student will be able to:

- CO1:** Explain theoretical aspects, processes and principles, the scope of Management and its application to modern management practice
- CO2:** Identify the Decision-making process in Business organizations
- CO3:** Differentiate the functions of Line and Staff management
- CO4:** Understand and apply different leadership styles
- CO5:** Apply different controlling techniques in different situations

Mapping of Course Outcomes with Program Outcomes:

CO / PO	PO1	PO2	PO3	PO4	PO5	PO6	PO7	PO8	PO9	PO10	PO11
CO1	3	2	2	1	1	1	-	2	1	1	1
CO2	2	3	3	1	1	2	1	1	2	1	1
CO3	2	2	2	1	1	3	-	1	1	2	1
CO4	1	2	2	2	1	3	1	2	1	2	2
CO5	2	3	3	1	1	2	-	1	2	1	2

Mapping of Course Outcomes with Program Specific Outcomes:

CO / PSO	PSO1	PSO2	PSO3
CO1	2	1	1
CO2	2	2	2
CO3	2	2	1
CO4	1	2	1
CO5	2	2	2

UNIT – I

Management: Definition, nature, significance and principles of management, Evolution of management thought, management and administration, levels of management, Functions of Management.

UNIT – II

Planning: Concept, Objectives, Types, Steps and Techniques, Decision Making: Steps in Decision Making and Types; Management by Objectives (MBO).

UNIT – III

Organizing & Staffing: Structures, Nature, Types and Principles of Organizing; Centralization and

Decentralization, Staffing: Nature, Significance and Process.

UNIT – IV

Leading and Directing: Introduction, Characteristics and Functions of a Leader; Leadership and Management, Styles of Leaders. **Directing:** Meaning and nature and importance of Directing.

UNIT-V

Controlling: Introduction, Concept of Controlling, Purpose of Controlling; Types of Control; Steps in Controlling; Techniques in Controlling.

Text Books:

1. P.C. Tripathi & P.N. Reddy, Principles of Management (2023), McGraw Hill, 6th Edition, ISBN: 9789352605354
2. Harold Koontz & Heinz Weihrich, Essentials of Management (2015), McGraw Hill, 10th Edition, ISBN: 9789339222864

Reference Books:

1. Gerald Cole, Management: Theory and Practice (2020), Cengage, ISBN: 9781473769724
2. OpenStax, Principles of Management (2019) XanEdu Publishing Inc, Ed., ISBN: 9781593998769

Web Links:

1. https://onlinecourses.nptel.ac.in/noc23_mg33/preview
2. <https://archive.nptel.ac.in/courses/110/107/110107150/>

Relevant cases have to be discussed in each unit and in examination case study is compulsory from any unit.

FINANCIAL ACCOUNTING

Course Code: 2505BB49 L T P C
2 1 3

Course Outcomes:

At the end of the Course, Student will be able to:

- CO1:** Identify and explain key concepts and principles of financial accounting.
- CO2:** Assess accounting concepts, principles, standards, and policies.
- CO3:** Apply the accounting process to record transactions and compute depreciation.
- CO4:** Simplify Trading, Profit & Loss Accounts, and Balance Sheets for sole proprietary businesses.
- CO5:** Analyze final accounts of companies in line with the Companies Act, 2013

Mapping of Course Outcomes with Program Outcomes:

CO / PO	PO1	PO2	PO3	PO4	PO5	PO6	PO7	PO8	PO9	PO10	PO11
CO1	3	2	2	1	2	-	-	1	1	-	1
CO2	3	3	2	1	3	-	-	1	2	-	1
CO3	3	3	2	1	2	-	-	1	2	-	1
CO4	3	2	2	1	2	-	-	1	1	1	1
CO5	3	3	2	1	3	-	-	2	2	1	2

Mapping of Course Outcomes with Program Specific Outcomes:

CO / PSO	PSO1	PSO2	PSO3
CO1	3	2	2
CO2	3	3	2
CO3	3	3	2
CO4	3	2	2
CO5	3	3	3

UNIT – I

Introduction to Financial Accounting: Definition, Scope, objectives of Financial Accounting, Accounting v/s Book Keeping, Double entry system of accounting and its advantages; types of accounts, rules of accounting.

UNIT – II

Conceptual Frame work: Accounting Concepts, Principles and Conventions, Brief review of Accounting Standards in India, GAAP (Generally Accepted Accounting Principles) and IFRS (International Financial Reporting Standards)

UNIT – III

Recording of Transactions: Voucher system; Accounting Process, Journal, Subsidiary Books, Ledger, Cash Book, Bank Reconciliation Statement, Trial Balance. Rectification of Errors; Depreciation: Need

& importance and methods of charging depreciation,

UNIT – IV

Preparation of Final Accounts: Preparation of Trading and Profit & Loss Account and Balance Sheet of sole proprietary business (with adjustments).

UNIT – V

Company Final Accounts: Understanding of final accounts of a Company. Joint Stock Company- Definition, Characteristics, types of companies, Shares, Share Capital, rights shares, bonus shares.

Text Books:

1. T.S. Grewal, Double Entry Book Keeping: Financial Accounting (2023), Sultan Chand & Sons, ISBN: 9788196162658
2. Amrish Gupta, Financial Accounting for Management (2021), Pearson, 5th Edition, ISBN: 9788131797556

Reference Books:

1. Rajesh Agarwal & R. Srinivasan, Accounting Made Easy (2020) McGraw Hill, 2nd Edition, ISBN: 9780070700987
2. R. Narayanaswamy, Financial Accounting: A Managerial Perspective (2017) PHI, 6th Edition, ISBN: 9788120353435

Web Links:

1. https://onlinecourses.nptel.ac.in/noc23_mg65/preview
2. <https://archive.nptel.ac.in/courses/110/101/110101131/>

Relevant cases have to be discussed in each unit and in examination case study is compulsory from any unit.

BUSINESS STATISTICS AND LOGIC

	L	T	P	C
Course Code: 2505BB44	2	1		3

Course Outcomes:

At the end of the Course, Student will be able to:

- CO1:** Explain the types of data and types of variables
- CO2:** Interpret various concepts of descriptive statistics
- CO3:** Analyze the theories of probability
- CO4:** Solve the problems related to Linear programming.
- CO5:** Develop various transportation models and game theory.

Mapping of Course Outcomes with Program Outcomes:

CO / PO	PO1	PO2	PO3	PO4	PO5	PO6	PO7	PO8	PO9	PO10	PO11
CO1	2	2	2	1	-	-	-	-	2	-	1
CO2	2	3	3	1	-	-	-	-	3	-	1
CO3	2	3	3	1	-	-	-	-	3	-	1
CO4	2	3	3	1	-	1	1	-	3	1	1
CO5	2	3	3	1	-	1	1	-	3	1	1

Mapping of Course Outcomes with Program Specific Outcomes:

CO / PSO	PSO1	PSO2	PSO3
CO1	2	2	1
CO2	3	3	2
CO3	3	3	2
CO4	3	3	3
CO5	3	3	3

UNIT – I

Introduction to Business Statistics: Statistics in Business, Types of data – Nominal, Ordinal, Interval, Ratio. Types of variables.

UNIT – II

Descriptive Statistics: Measure of central tendency, Measure of variability – Range, interquartile range, standard deviation, variance, coefficient of variation.

UNIT – III

Introduction to Probability: Theories of probability, Laws of probability, Inverse Probability. Revision of probability: BAYES' RULE, Discrete distribution – Binomial, Poisson, Continuous distribution – Uniform, normal.

UNIT – IV

Introduction to Linear Programming Problems (LP): LP Formulations – Graphical Solution – Simplex Method

UNIT – V

An Introduction to Logic: Number series, coding decoding and odd man out series, direction sense test, seating arrangements – linear and circular, blood relations, arithmetic and geometric progressions, Inductive and deductive reasoning.

Textbooks:

1. Richard I. Levin & David S. Rubin, Statistics for Management (2012) Pearson Education, 7th Edition, ISBN: 9780134762920
2. S.P. Gupta, Business Statistics (2021), Sultan Chand & Sons, Revised Edition, ISBN: 97893516111066

Reference Books:

1. Paul Newbold, William Carlson, Betty Thorne, Statistics for Business and Economics (2020) Pearson, 9th Edition, ISBN: 9781292315034
2. Robert stine and Dean foster, Statistics for business: Decision making and Analysis (2017) Pearson, 3rd Edition ISBN: 9780134497167

Web Links:

1. <https://archive.nptel.ac.in/courses/110/107/110107114/>
2. <https://archive.nptel.ac.in/noc/courses/noc21/SEM1/noc21-mg07/>

Relevant cases have to be discussed in each unit and in examination case study is compulsory from any unit.

MICRO ECONOMICS

Course Code: 2505BB57

L	T	P	C
2		1	3

Course Outcomes:

At the end of the Course, Student will be able to:

- CO1:** Understand the fundamentals of Micro Economics
- CO2:** Apply the knowledge of the mechanics of supply and demand to explain working of markets.
- CO3:** Explain relationships between production and costs.
- CO4:** Analyze the key characteristics and consequences of different forms of markets.
- CO5:** Examine the choices made by a rational consumer

Mapping of Course Outcomes with Program Outcomes:

CO / PO	PO1	PO2	PO3	PO4	PO5	PO6	PO7	PO8	PO9	PO10	PO11
CO1	3	2	1	2	-	-	-	-	2	-	1
CO2	3	3	2	2	-	-	1	-	3	-	1
CO3	3	3	2	2	-	-	1	-	3	-	1
CO4	3	3	2	2	1	1	1	-	3	1	1
CO5	3	3	2	2	1	-	1	-	3	1	1

Mapping of Course Outcomes with Program Specific Outcomes:

CO / PSO	PSO1	PSO2	PSO3
CO1	2	2	1
CO2	3	2	2
CO3	3	2	2
CO4	3	3	2
CO5	3	3	2

UNIT – I

Introduction to Economics: Definition, Nature and Scope of Economics. Micro and Macro Economics, Role of Economics in Decision Making.

UNIT – II

Demand Analysis: Meaning of Demand, Types of Demand, Law of demand, Determinants of Demand, Demand Function, Elasticity of demand- price elasticity of demand. Income elasticity of demand, Cross Elasticity of demand,

UNIT – III

Production and Cost Analysis: Production function, Factors of Production, Types of Production Function, Law of Returns, Law of variable proportions, Isoquants and Iso cost Curves, Cost Concepts, Cost Output Relation (Short Run & Long Run Costs).

UNIT - IV

Market Structures: Perfect competition, monopoly, monopolistic competition, oligopoly basic features, equilibrium price, short run equilibrium of firm/industry, long run equilibrium of firm/industry.

UNIT – V

Consumer's Behaviour: Law of diminishing Marginal Utility Analysis, Indifference Curve Analysis and its Properties; Marginal rate of Substitution, Consumer Equilibrium.

Textbooks:

1. Dr. D.M. Mithani, Microeconomics Himalaya Publishing House, ISBN: 978-93-6557-962- 8
2. Pankaj Tandon, Microeconomic Theory Routledge India, ISBN: 978-1032789668

Reference Books:

1. Sreejata Banerjee & Robert S. Pindyck, Microeconomics Pearson India,9th Edition, ISBN: 978-9356060128.
2. David Besanko, Ronald Braeutigam, Tamali Chakraborty, Microeconomics: Indian Adaptation, Wiley India, 6th Edition, ISBN: 978-9354249136

Web Links:

1. <https://archive.nptel.ac.in/courses/110/104/110104093/>
2. <https://archive.nptel.ac.in/courses/109/104/109104125/>

Relevant cases have to be discussed in each unit and in examination case study is compulsory from any unit.

HUMAN BEHAVIOR AND ORGANIZATION

Course Code: 2505BB08

L	T	P	C
2		1	3

Course Outcomes:

At the end of the Course, Student will be able to:

- CO1:** Outline the overall perspective on human behavior in the work place.
- CO2:** Demonstrate the importance of motivation in at work place.
- CO3:** Examine the nature of group conflict and its resolution
- CO4:** Identify the impact of culture on individual performance
- CO5:** Analyze the impact of change, assess and manage work stress.

Mapping of Course Outcomes with Program Outcomes:

COs / POs	PO1	PO2	PO3	PO4	PO5	PO6	PO7	PO8	PO9	PO10	PO11
CO1	3	2	2	2	2	3	1	3	1	3	2
CO2	3	2	2	2	2	3	1	2	1	3	2
CO3	3	3	3	2	2	3	2	3	1	3	2
CO4	2	2	3	3	3	2	1	3	1	3	2
CO5	2	3	3	3	2	3	1	3	2	3	3

Mapping of Course Outcomes with Program Specific Outcomes:

CO / PSO	PSO1	PSO2	PSO3
CO1	1	1	2
CO2	2	1	2
CO3	2	1	2
CO4	2	1	2
CO5	2	1	2

UNIT – I

Introduction to Human Behavior and Organization: Meaning and importance of Organizational Behavior (OB); Evolution and factors influencing OB; OB models and their relevance in modern organizations.

UNIT – II

Individual Behavior: Personality –Determinants, Type A & B, Big Five traits; Attitude – Components and job-related attitudes; Learning theories and reinforcement; Perception – Process and influencing factors; Values – Terminal and instrumental; Motivation – Early (Maslow, McGregor, Herzberg) and contemporary theories (Self-Determination, Goal-Setting, Reinforcement, Self-Efficacy).

UNIT – III

Group and Team Behavior: Concepts and differences between groups and teams; Five-stage model of group development; Groupthink, group shift, and Indian perspective on group norms; Types of teams and development; Conflict management in groups and virtual/e-teams.

UNIT – IV

Leadership and Power: Leadership – Concepts, trait and behavioral theories, contingency theories; Contemporary leadership styles (transformational, charismatic, authentic); Mentoring and self- leadership; Cross-cultural leadership comparisons; Bases and types of power.

UNIT – V

Organizational Culture and Stress Management: Organizational culture – Meaning, functions, and creating ethical cultures; Role of employees in shaping culture; Cross-cultural management in globalized workplaces; Stress – Causes, types, and stress management strategies.

Text Books:

1. L.M. Prasad, Organizational Behaviour, Sultan Chand & Sons, ISBN: 9789351611462.
2. Dr.Kavita Singh, Organizational Behaviour: Text and Cases, Pearson India, ISBN: 9781282652729

Reference Books:

1. Nahar Amandeep, Rao PCK, Nigah Rajesh Kumar, Organisational Behaviour(2021), Sultan Chand & Sons ISBN: 93-5161-199-82.
2. Jerald Greenberg, Behavior in Organizations, Pearson Education India, 10 Edition, ISBN- 10: 9332556997, ISBN-13: 978-9332556997

Web Links:

1. <https://archive.nptel.ac.in/courses/110/106/110106145/>
2. https://onlinecourses.nptel.ac.in/noc20_mg51/preview

Relevant cases have to be discussed in each unit and in examination case study is compulsory from any unit

MARKETING MANAGEMENT

Course Code: 2505BB55

L	T	P	C
2		1	3

Course Outcomes:

At the end of the Course, Student will be able to:

- CO1:** Explain marketing and analyze the core marketing concepts
- CO2:** Assess and select market segments based on effective segmentation criteria
- CO3:** Classify products, analyze the product life cycle, and propose strategies for new product development
- CO4:** Develop pricing strategies, explain the relevance of the value chain to marketing, and assess customer lifetime value
- CO5:** Design integrated marketing channels, manage retailing and logistics, and evaluate the effectiveness of various promotional strategies

Mapping of Course Outcomes with Program Outcomes:

COs / POs	PO1	PO2	PO3	PO4	PO5	PO6	PO7	PO8	PO9	PO10	PO11
CO1	3	2	1	2	2	1	1	2	2	1	1
CO2	3	3	2	2	2	1	1	2	2	2	1
CO3	3	2	2	2	2	1	2	2	2	2	2
CO4	3	3	2	2	2	1	2	2	2	2	1
CO5	3	2	2	2	2	2	2	3	3	2	2

Mapping of Course Outcomes with Program Specific Outcomes:

CO / PSO	PSO1	PSO2	PSO3
CO1	3	1	1
CO2	3	1	1
CO3	3	1	1
CO4	3	1	1
CO5	3	1	1

UNIT – I

Introduction to Marketing and Environment: Nature, scope, and importance of marketing; Evolution of marketing concepts (Production, Product, Selling, Marketing, Holistic); Types of marketing (B2C, B2G, B2B, C2C); Marketing environment (Demographic, Economic, Political, Legal, Socio-cultural, Technological); Market and competition analysis; Creating customer value.

UNIT – II

Consumer Behavior and Market Segmentation: Segmentation, Targeting, and Positioning; Bases for segmenting consumer markets; Consumer behavior (Stimulus Response Model, Cultural, Social, Personal, Psychological factors); Consumer buying decision process; Business buyer behavior; Traditional vs. Experiential marketing.

UNIT – III

Product and Pricing Decisions: Product Life Cycle (PLC) and marketing strategies; Product classification, line, and mix decisions; Branding, packaging, labeling; BCG Matrix; Brand management; Innovation and new product development; Pricing determinants and methods.

UNIT – IV

Promotion and Distribution Decisions: Promotion mix and factors; Promotional tools (Advertising, Sales Promotion, PR, Publicity, Personal Selling); Marketing channels and intermediaries (Wholesalers, Retailers); Introduction to retail management.

UNIT – V

Services and Contemporary Marketing: Services marketing (7Ps); Contemporary marketing issues (E-commerce, Digital Marketing, Online payments); Ethical and social responsibility; Rural marketing, social marketing, green marketing.

Text Books:

1. Kotler, P., Keller, K. L., Chernev. A., Sheth. J.N., Shainesh G., Marketing Management (2022), Pearson Education, 16th Edition, ISBN-10. 9356062668; ISBN-13. 978-9356062665
2. Dr. K. Karunakaran, Marketing Management, Himalaya Publishing House, ISBN: 978-93-5693-548-8

Reference Books:

1. Hartley, S. W., Kerin, R. A., Marketing (2021), United States: McGraw-Hill Education, 15th Edition, and ISBN-10. 1260260364; ISBN-13. 978-1260260366
2. Prof. Sunil Tiwari and Dr. Richa Tiwari, Strategic International Marketing, Society Publishing, ISBN: 9781779563798

Web Links:

1. https://onlinecourses.nptel.ac.in/noc22_mg57/preview
2. <https://archive.nptel.ac.in/courses/110/104/110104068/>

Relevant cases have to be discussed in each unit and in examination case is compulsory from any unit.

MACRO ECONOMICS

Course Code: 2505BB12

L	T	P	C
2		1	3

Course Outcomes:

At the end of the Course, Student will be able to:

- CO1:** Explain the concepts of National Income
- CO2:** Identify the Basics of Fiscal policy and its importance
- CO3:** Compare the relationships between monetary policy and flow of cash in economy.
- CO4:** Analyze the key characteristics and consequences of Business cycles and Balance of Payments.
- CO5:** Examine the concepts of inflation and unemployment

Mapping of Course Outcomes with Program Outcomes:

COs / POs	PO1	PO2	PO3	PO4	PO5	PO6	PO7	PO8	PO9	PO10	PO11
CO1	3	2	1	2	2	1	1	2	1	1	1
CO2	3	3	2	2	2	2	1	2	1	1	1
CO3	3	3	2	2	2	2	2	2	1	1	1
CO4	3	3	2	2	2	2	2	2	1	1	1
CO5	3	3	2	2	2	2	1	2	1	1	1

Mapping of Course Outcomes with Program Specific Outcomes:

CO / PSO	PSO1	PSO2	PSO3
CO1	2	2	2
CO2	2	3	2
CO3	2	3	2
CO4	2	3	2
CO5	2	3	2

UNIT – I

Introduction to Macro Economics and National Income: Introduction Meaning and Scope of Macro Economics, introduction to Classical and Keynesian theory, Definition, Concepts of National income, Measurement of National Income.

UNIT – II

Monetary Policy: meaning, objectives and components; credit creation; money multiplier; tools of monetary policy- open market operation.

UNIT – III

Fiscal Policy: meaning, objectives and components; revenue receipts, capital receipts, revenue expenditure, capital expenditure, government deficit, revenue deficit, fiscal deficit, primary deficit.

UNIT – IV

Business Cycles and Balance of Payments: Business cycle; phases of business cycle, measures to control Business cycles. Balance of trade, Trade Deficit, Balance of Payments.

UNIT – V

Inflation and Unemployment: Concept of inflation; determinants of inflation; types of inflation; relationship between inflation and unemployment.

Text Books:

1. Dr. Amritkant Mishra, Modern Macroeconomics, Bridging Concepts to Realities Sultan Chand & Sons, ISBN-13: 978-81-8054-890-1
2. C B Sachdeva, Introductory Macroeconomics, Geeta Publishing House, ISBN-13: 978-9395904049

Reference Books:

1. Jones, CW. W. Norton, Macroeconomics. 4th edition. ISBN-10, 0393603768. ISBN-13, 978-0393603767
2. S.N.V. Siva Kumar, Asha Prasuna, Macroeconomics and Policy for Managers: An Indian Perspective, Cengage India, 2nd Edition, ISBN-13: 978-9355739469

Web Links:

1. https://onlinecourses.swayam2.ac.in/cec22_hs08/preview
2. <https://archive.nptel.ac.in/courses/130/104/130104114/>

Relevant cases have to be discussed in each unit and in examination case study is compulsory from any unit.

COST AND MANAGEMENT ACCOUNTING

Course Code: 2505BB04

L	T	P	C
2	1		3

Course Outcomes:

At the end of the Course, Student will be able to:

- CO1:** Explain the Concept of Cost and Management Accounting
- CO2:** Select the Elements of Material, Labour and Overhead Cost
- CO3:** Preparation of Cost sheet
- CO4:** Analyze the Concept Marginal Costing and CVP analysis
- CO5:** Evaluation techniques of Budgeting

Mapping of Course Outcomes with Program Outcomes:

CO / PO	PO1	PO2	PO3	PO4	PO5	PO6	PO7	PO8	PO9	PO10	PO11
CO1	3	2	3	2	3	3	2	2	3	3	3
CO2	3	3	3	3	2	2	3	3	3	3	2
CO3	3	3	3	2	3	3	3	3	3	3	3
CO4	3	3	3	3	3	2	2	3	3	3	3
CO5	3	2	3	3	3	3	3	2	3	3	3

Mapping of Course Outcomes with Program Specific Outcomes:

CO / PSO	PSO1	PSO2	PSO3
CO1	3	2	3
CO2	3	3	2
CO3	3	3	3
CO4	3	3	3
CO5	3	2	3

UNIT – I

Introduction to Cost and Management Accounting: Definition, Nature, Objectives, Scope, Advantages and Limitations of Cost Accounting: Definition, Nature, Objectives, Scope, Advantages and Limitations of Management Accounting: Cost Accounting Vs. Management Accounting Vs. Financial Accounting.

UNIT – II

Marginal Costing and Budgetary Control: Meaning and importance of Marginal Costing. Marginal Cost Equation, Break-even Analysis, P/V ratio, Margin of Safety. Types of budgets, flexible budget, and cash budget. Budgetary control and practical problems.

UNIT – III

Financial Statement Analysis: Comparative Income Statements, Balance Sheets, Common Size analysis, and Trend Analysis. Ratio Analysis: liquidity, solvency, profitability, leverage, and turnover ratios, and their interpretation.

UNIT – IV

Cash Flow Statement: Concept of cash flow, sources of cash flow (operating, financing, investing), inflows, and outflows of cash. Preparation of cash flow statements with adjustments.

UNIT – V

Management Reporting: Meaning, purpose, and objectives of management reports. Reports for top and lower-level management. Sample reports.

Text Books:

1. M.P. Gupta & Dr. Ajay Gupta, Cost and Management Accounting, Sultan Chand & Sons, ISBN: 978-93-91820-47-3
2. Ravi M. Kishore, Cost & Management Accounting, Foundational to Advanced Concepts (Reprint 2025), Taxmann Publications, 6th Edition, ISBN: 978-93-92211-13-3

Reference Books:

1. S.N.Maheswari, Cost and Management Accounting, Sultan Chand Publications, ISBN- 10. 8180549755; ISBN-13. 978-8180549755
2. CA Sunil Keswani, Cost & Management Accounting, Bharat Law House, ISBN: 978-93- 90854-07-3

Web Links:

1. <https://archive.nptel.ac.in/courses/110/101/110101132/>
2. https://onlinecourses.nptel.ac.in/noc20_mg53/preview

Relevant cases have to be discussed in each unit and in examination case study is compulsory from any unit.

LEGAL AND ETHICAL ISSUES IN BUSINESS

Course Code: 2505BB54

L	T	P	C
2		1	3

Course Outcomes:

At the end of the Course, Student will be able to:

- CO1:** Identify fundamental legal principal behind contractual Agreements
- CO2:** Explain the salient features of Sale of Goods Act and Negotiable Instruments Act
- CO3:** Assume the consequences of applicability of Companies Act and Partnership Act in business situations.
- CO4:** Build critical thinking through the use of Consumer Rights.
- CO5:** Develop awareness in respect of rules and regulations for Environment Protection.

Mapping of Course Outcomes with Program Outcomes:

COs / POs	PO1	PO2	PO3	PO4	PO5	PO6	PO7	PO8	PO9	PO10	PO11
CO1	3	2	3	2	3	2	2	2	2	2	2
CO2	3	3	2	2	3	2	2	2	2	2	2
CO3	3	3	3	2	3	2	2	2	2	2	2
CO4	3	3	2	2	3	2	2	2	2	2	2
CO5	3	2	2	2	3	2	2	2	2	2	2

Mapping of Course Outcomes with Program Specific Outcomes:

CO / PSO	PSO1	PSO2	PSO3
CO1	3	2	3
CO2	3	3	2
CO3	3	3	3
CO4	3	3	3
CO5	3	2	3

UNIT – I

The Indian Contract Act 1872: Essentials, types, offer & acceptance, consideration, competency, free consent, void agreements, performance, discharge, breach, quasi contract.

Special Contracts: Indemnity, guarantee, bailment, pledge, agency.

UNIT – II

The Sale of Goods Act 1930: Sale vs. agreement to sell, conditions & warranties, transfer of property, unpaid seller's rights.

The Negotiable Instruments Act 1881: Types, parties, dishonor, discharge, promissory note, bill of exchange, cheque.

UNIT – III

The Companies Act 2013: Types, incorporation, MOA & AOA, prospectus, shares, role of directors, company meetings.

The Limited Liability Partnership Act 2008: Nature, formation, partners' relations, liability limitations.

UNIT – IV

The Consumer Protection Act 1986: Consumer rights, disputes, redressal mechanisms.

Right to Information Act 2005: Features, definitions, obligations of authorities, request process, PIO functions.

UNIT – V

The Information Technology Act 2000: Digital Signatures, e-governance, cyber laws.

The Environment Protection Act 1986: Water & air pollution, Green Tribunal, sustainability reporting.

Text Books:

1. Kenneth W. Clarkson et al., Business Law: Text and Cases (2017), Cengage Learning, 14th Edition, ISBN: 9781305967250
2. P.C. Tulsian, Business Law (2021), McGraw Hill, 3rd Edition, ISBN: 9789354600318

Reference Books:

1. Ravinder Kumar, Legal Aspects of Business (2021) Cengage India, 4th Edition, ISBN: 9789387511767
2. N.D. Kapoor, Elements of Mercantile Law (2022), Sultan Chand & Sons, 38th Edition, ISBN: 9789351618323

Web Links:

1. https://onlinecourses.swayam2.ac.in/cec21_mg02/preview
2. <https://www.classcentral.com/course/swayam-fundamentals-of-legal-aspects-of-business-22987>

Relevant cases have to be discussed in each unit and in examination case study is compulsory from any unit.

HUMAN RESOURCE MANAGEMENT

Course Code: 2505BB09

L	T	P	C
2		1	3

Course Outcomes:

At the end of the Course, Student will be able to:

- CO1:** Explain HRM evolution, functions, and trends
- CO2:** Analyze HR planning, job analysis, recruitment, and selection.
- CO3:** Assess training needs, design training programs, and evaluate executive development
- CO4:** Appraise employee performance and evaluate wage administration.
- CO5:** Understand industrial relations, dispute causes, and trade union effectiveness.

Mapping of Course Outcomes with Program Outcomes:

CO / PO	PO1	PO2	PO3	PO4	PO5	PO6	PO7	PO8	PO9	PO10	PO11
CO1	3	2	3	3	2	3	3	3	3	2	3
CO2	3	3	3	2	3	3	3	3	2	3	3
CO3	3	3	3	3	3	2	3	3	2	3	3
CO4	3	3	3	3	3	3	2	3	3	3	3
CO5	3	2	3	3	3	3	3	3	3	3	3

Mapping of Course Outcomes with Program Specific Outcomes:

CO / PSO	PSO1	PSO2	PSO3
CO1	3	2	3
CO2	3	3	3
CO3	3	3	3
CO4	3	3	3
CO5	3	2	3

UNIT - I

Introduction to Human Resource Management (HRM): Overview of HRM, HRM as a business partner, policies, and HRM in a competitive global environment. Introduction to functional and strategic HRM.

UNIT - II

HR Planning and Talent Management: Employee life cycle, HR planning, recruitment, selection, training and development, competency management, career management, and managing gig/virtual employees.

UNIT - III

Employee Engagement, Performance, and Compensation: Employee engagement, performance management, compensation strategies, benefits, compensation for special groups, industrial relations, workplace laws, and employment relations.

UNIT - IV

HR Technology and Analytics: Human Resource Information Systems (HRIS), HR analytics, innovations in HRM, HRM in SMEs and the service sector, HR leadership, and organizational transformation.

UNIT - V

Diversity, Inclusion, and HR Challenges: Diversity, equity, and inclusion, workplace wellness, sustainability goals, green HRM, and the challenges faced in modern HRM.

Text Books:

1. Gary Dessler, Biju Varkkey, Human Resource Management (2020), Pearson Education, 9789352862658; ISBN-13. 978-9352862658
2. R.C. Sharma & Nipun Sharma, Human Resource Management: Concepts, Theories and Contemporary Practices, Routledge India, ISBN: 978-1032623160

Reference Books:

1. Amitabha Sengupta, Human Resource Management: Concepts, Practices, and Paradigms, Cengage India, 2nd Edition, ISBN: 978-9355739438
2. Aswathappa K, Human Resource Management: Text and Cases (2021), Tata McGraw-Hill, ISBN- 10. 9354600212; ISBN-13. 978-9354600210

Web Links:

1. <https://archive.nptel.ac.in/courses/110/105/110105069/>
2. https://onlinecourses.nptel.ac.in/noc21_mg21/preview

Relevant cases have to be discussed in each unit and in examination case is compulsory from any unit.

BUSINESS ENVIRONMENT AND PUBLIC POLICY

Course Code: 2505BB43

L	T	P	C
2		1	3

Course Outcomes:

At the end of the Course, Student will be able to:

- CO1:** Explain the nature, dimensions, and challenges of the business environment at both micro and macro levels.
- CO2:** Explain the global business frameworks and their impact on the Indian economy and national development.
- CO3:** Demonstrate an understanding of key public policies and analyze their impact on the Indian economy and reforms.
- CO4:** Analyze the major economic challenges in India and evaluate remedies and opportunities within the business environment.
- CO5:** Analyze emerging business trends and assess their impact on the digital economy, outsourcing, and technological growth.

Mapping of Course Outcomes with Program Outcomes:

COs / POs	PO1	PO2	PO3	PO4	PO5	PO6	PO7	PO8	PO9	PO10	PO11
CO1	3	2	2	2	2	2	2	2	2	2	2
CO2	3	2	2	2	2	2	2	2	2	2	2
CO3	3	3	2	2	3	2	2	2	2	2	2
CO4	3	3	2	2	2	2	2	2	2	2	2
CO5	3	3	2	2	3	2	2	2	2	2	2

Mapping of Course Outcomes with Program Specific Outcomes:

CO / PSO	PSO1	PSO2	PSO3
CO1	3	2	2
CO2	3	3	2
CO3	3	3	3
CO4	3	3	3
CO5	3	3	3

UNIT – I

Theoretical Framework of Business Environment: Concept, Significance and Nature of Business Environment. Micro and Macro Dimensions of Business Environment, Changing Dimensions of Business Environment. Problems and Challenges of Indian Business Environment.

UNIT – II

Global Framework: EPRG Framework, Liberalization, Privatization & Globalization concept & its impact on Indian Economy. Significance of FDI & FII, IMF & WTO, Regional Economic Integrations in the development of the Nations.

UNIT – III

Public Policies: Background, Meaning and Importance of Public Policy. Significance of Industrial Policy, Fiscal Policy, Monetary Policy, Foreign Trade Policy, FERA & FEMA. Structural Adjustment Programs and Banking Sector Reforms in India.

UNIT – IV

Problems and Challenges of Growth of Economy: Unemployment, Poverty, Regional Imbalance. Social Injustice, Inflation, Parallel economy, Lack of technical knowledge and information. Remedies to solve these problems, Challenges & Opportunities of Indian Business Environment.

UNIT – V

Emerging Trends in Business: Concepts, Advantages and Limitations-Franchising, Aggregators, Business Process Outsourcing (BPO) & Knowledge Process Outsourcing (KPO); E-Commerce, Digital Economy. Technological Growth and MNC's.

Text Books:

1. Dr. V. Basil Hans, Business Environment, IIP Publications, ISBN: 978-93-5747-517-4
2. Faisal Ahmed & M. Absar Alam, Business Environment: Indian and Global Perspective, PHI Learning, 3rd Edition, ISBN: 978-9354437731

Reference Books:

1. Risha Khandelwa, Business Environment (2024), Toronto Academic Press, ISBN: 978-1774697375
2. Vishwajeet Prasad, Business Environment, GenNext Publication, ISBN: 978-9356633667.

Web Links:

1. https://onlinecourses.swayam2.ac.in/imb22_mg02/preview
2. https://ugcmoocs.inflibnet.ac.in/index.php/courses/view_pg/389

Relevant cases have to be discussed in each unit and in examination case study is compulsory from any unit.

ENTREPRENEURSHIP AND STARTUP ECO-SYSTEM

	L	T	P	C
Course Code: 2505BB47	2	1		3

Course Outcomes:

At the end of the Course, Student will be able to:

- CO1:** Understand entrepreneurship and its role in economic development
- CO2:** Identify entrepreneurial strategies, business models, and competencies.
- CO3:** Analyze the startup environment and business plan components.
- CO4:** Compare funding sources and government support for startups
- CO5:** Explore institutions supporting business enterprises

Mapping of Course Outcomes with Program Outcomes:

CO / PO	PO1	PO2	PO3	PO4	PO5	PO6	PO7	PO8	PO9	PO10	PO11
CO1	3	2	2	3	2	1	1	1	2	1	2
CO2	3	3	2	2	2	2	2	2	3	2	2
CO3	2	3	3	3	2	2	2	1	3	2	3
CO4	2	2	2	2	3	3	2	1	2	2	2
CO5	2	2	2	1	2	2	3	2	2	1	2

Mapping of Course Outcomes with Program Specific Outcomes:

CO / PSO	PSO1	PSO2	PSO3
CO1	3	3	3
CO2	3	3	3
CO3	3	3	3
CO4	3	3	3
CO5	3	3	3

UNIT - I

Introduction to Entrepreneurship & Family Business: Definition and concept of entrepreneurship, characteristics of entrepreneurs, types of entrepreneurs, the role of entrepreneurship in economic development, and start-ups. Characteristics of family businesses, with examples from Indian family businesses like Murugappa, Dabur, Wadia, Godrej, and Kirloskar.

UNIT - II

Evaluating Business Opportunities: Sources of business ideas, recognizing opportunities, estimating market potential, feasibility analysis of business ideas, and analyzing industry, competition, and the business environment.

UNIT - III

Building Blocks of Starting Ventures: Low-cost marketing using digital technologies, team building from scratch, securing venture funding, establishing the value chain, managing operations, and understanding legal aspects like Intellectual Property Rights (IPR) and compliance.

UNIT - IV

Start-up Ecosystem: Understanding the start-up ecosystem components, including incubators, accelerators, venture capital funds, angel investors, and government schemes like Start-up India, Digital India, and MSME. Sources of venture funding and intellectual property management in India.

UNIT - V

Technology and Innovation in Start-ups: Sources of technology for start-ups, managing intellectual property, and leveraging innovation for growth in start-ups.

Text Books:

1. Robert Hisrich, Michael Peters, and Dean Shepherd, Entrepreneurship (2019), McGraw Hill Education, 11th Edition, ISBN-10. 939011330X · ISBN-13. 978- 9390113309
2. Fabio Greco, Startup Ecosystems (2023) Springer publications, ISBN-13-978- 3031344138

Reference Books:

1. Dr. N. M. Louly, Dr. Mohammed Quadir Mohiuddin, Dr. Aarti Deshpande, Dr. B. Kavitha, Entrepreneurship Basics, REST Publisher, ISBN: 978-81-967493-7-8
2. Dr. K. Suresh, Sheetal V. Hukkeri, Dr. S. Ragavan, Dr. V. Sasirekha, Fundamentals of Entrepreneurship (2024), REST Publisher, ISBN: 978-81-966857-3-7

Web Links:

1. https://onlinecourses.nptel.ac.in/noc20_mg35/preview
2. https://onlinecourses.swayam2.ac.in/imb23_mg27/preview?ref=schoolokay.in

Relevant cases have to be discussed in each unit and in examination case study is compulsory from any unit.

OPERATIONS MANAGEMENT

Course Code: 2505BB58

L	T	P	C
2		1	3

Course Outcomes:

At the end of the Course, Student will be able to:

- CO1:** Understand the Relationship of Operations management with other functional areas and different types of Production Systems.
- CO2:** Apply stages of the product design process, analyze value analysis techniques, and critique facility location and layout decisions
- CO3:** Evaluate methods of forecasting, design operation planning strategies, and assess capacity planning techniques including MRP and scheduling
- CO4:** Analyze factors affecting productivity, apply job design principles, and evaluate process flow charts and methods study
- CO5:** Examine the techniques of Statistical Quality Control and Total - Quality Management.

Mapping of Course Outcomes with Program Outcomes:

COs / POs	PO1	PO2	PO3	PO4	PO5	PO6	PO7	PO8	PO9	PO10	PO11
CO1	3	3	3	3	3	3	2	3	3	3	3
CO2	3	3	3	3	3	3	2	3	3	3	3
CO3	3	3	3	3	3	3	2	3	3	3	3
CO4	3	3	3	3	3	3	2	3	3	3	3
CO5	3	3	3	3	3	3	2	3	3	3	3

Mapping of Course Outcomes with Program Specific Outcomes:

CO / PSO	PSO1	PSO2	PSO3
CO1	3	3	3
CO2	3	3	3
CO3	3	3	3
CO4	3	3	3
CO5	3	3	3

UNIT – I

Introduction to Operation Management: Nature, Scope, Recent trends in Operation Management, Manufacturing & Theory of Constraint, Types of Production System, Just in Time (JIT) & lean system.

UNIT – II

Product Design & Process Selection: Stages in Product Design process, Value Analysis, Facility Location & Layout: Types, Characteristics, Advantages and Disadvantages.

UNIT – III

Forecasting & Capacity Planning: Methods of Forecasting, Production strategies, Capacity Requirement Planning, MRP, Scheduling, Supply Chain Management, Purchase Management, Inventory Management.

UNIT – IV

Productivity: Factors Affecting Productivity – Job Design – Process Flow Charts – Methods Study – Work Measurement – Engineering and Behavioral Approaches.

UNIT – V

Quality Management: Cost of Quality, Quality Circles, ISO (9000&14000 Series), Statistical Quality Control, Control Charts -Acceptance Sampling Operating Characteristic Curve (AQL, LTPD, Alpha & Beta risk), Total Quality Management (TQM).

Text Books:

1. Lee J. Krajewski, Manoj K. Malhotra, Operations Management: Processes and Supply (2021) Chains Pearson, 13th Edition, ISBN: 9780136860938
2. William J. Stevenson, Operations Management (2017) McGraw Hill, 13th Edition, ISBN: 9781259667473

Reference Books:

1. K. Aswathappa & K. Shridhara Bhat, Production and Operations Management (2020), Himalaya Publishing, 2nd Edition, ISBN: 9789352621247
2. S. Anil Kumar, N. Suresh, Operations Management (2018), New Age International, 3rd Edition, ISBN: 9788122437257

Web Links:

1. https://onlinecourses.nptel.ac.in/noc20_me30/preview
2. <https://archive.nptel.ac.in/courses/112/107/112107238/>

Relevant cases have to be discussed in each unit and in examination case study is compulsory from any unit.

FINANCIAL MANAGEMENT

	L	T	P	C
Course Code: 2505BB07	2	1		3

Course Outcomes:

At the end of the Course, Student will be able to:

- CO1:** Demonstrate the concept of time value of money.
- CO2:** Explain about the capital budgeting techniques and cost of capital.
- CO3:** Analyze the significance of Capital structure vs. financial structure.
- CO4:** Assess dividend policies of Indian companies, determinants of working capital, analysis of investment in inventory.
- CO5:** Examine the Concepts and Applications of Working Capital Management and Management of Current Assets.

Mapping of Course Outcomes with Program Outcomes:

CO / PO	PO1	PO2	PO3	PO4	PO5	PO6	PO7	PO8	PO9	PO10	PO11
CO1	3	3	3	2	3	2	2	2	3	2	3
CO2	3	3	3	2	3	2	2	2	3	2	3
CO3	3	3	3	2	3	3	2	2	3	2	3
CO4	3	3	3	2	3	3	2	3	3	2	3
CO5	3	3	3	3	3	3	2	3	3	2	3

Mapping of Course Outcomes with Program Specific Outcomes:

CO / PSO	PSO1	PSO2	PSO3
CO1	3	3	3
CO2	3	3	3
CO3	3	3	3
CO4	3	3	3
CO5	3	3	3

UNIT - I

Introduction to Financial Management: Overview of financial management, its objectives (profit and wealth maximization), scope, and financial decisions. Discussion on factors influencing financial decisions, sources of finance (equity, debt, internal financing), and startup finance.

UNIT - II

Capital Structure and Capitalization: Capitalization theories (cost and earnings), over and under capitalization, causes and effects, capital structure principles, determinants, and capital gearing. Practical issues related to EBIT-EPS analysis and the effect of capital structure on financial performance.

UNIT - III

Cost of Capital and Leverages: Understanding cost of capital, its significance, and components. Leverage types (operating, financial, and combined), risk and return analysis, and practical problems. Managing working capital, including cash, inventory, and debtor management.

UNIT - IV

Capital Budgeting: Introduction to capital budgeting, time value of money, and project appraisal methods (Payback Period, NPV, IRR, MIRR). Practical problems on capital budgeting techniques for decision making.

UNIT - V

Dividend Policy: Discussion on dividend policy, types, theories, and factors influencing dividend decisions. Legal and regulatory framework related to dividend distribution, including Companies Act 2013 and SEBI guidelines.

Text Books:

1. Prasanna Chandra, Financial Management: Theory & Practice (2022), McGraw- Hill, 11th Edition, ISBN-10: 9355322208, ISBN-13: 978-9355322203-978
2. Surender Singh, Financial Management (2024), Scholar Tech Press, NEP, Edition, ISBN: 978-9391720131;

Reference Books:

1. Financial Management -Global EduTech; 12th Edition, ASIN B096KXDN1L
2. Shaifali Mathur & Richa Thakur, Financial Management (2023) Neelkanth Publishers Pvt. Ltd., ISBN: 978-9389462104

Web Links:

1. https://onlinecourses.nptel.ac.in/noc20_mg31/preview
2. <https://archive.nptel.ac.in/courses/110/107/110107144/>

Relevant cases have to be discussed in each unit and in examination case study is compulsory from any unit.

BUSINESS RESEARCH METHODOLOGY

Course Code: 2505BB44	L	T	P	C
	2	1		3

Course Outcomes:

At the end of the Course, Student will be able to:

- CO1:** Explain the fundamentals of research, its types, ethical considerations, and the characteristics of good research.
- CO2:** Explain the process of identifying research problems, setting objectives, reviewing literature, and understanding research design types.
- CO3:** Apply appropriate measurement techniques and data collection methods for conducting effective research.
- CO4:** Analyze and evaluate sampling techniques and perform data preparation for effective research analysis.
- CO5:** Analyze and interpret research data using statistical tools and visualization techniques for effective decision-making.

Mapping of Course Outcomes with Program Outcomes:

CO / PO	PO1	PO2	PO3	PO4	PO5	PO6	PO7	PO8	PO9	PO10	PO11
CO1	3	3	3	3	2	2	3	3	2	3	3
CO2	3	3	3	3	2	2	3	3	2	3	3
CO3	3	3	2	3	2	3	3	2	2	3	3
CO4	3	3	2	3	2	3	3	2	2	3	3
CO5	3	3	2	3	2	3	3	2	2	3	3

Mapping of Course Outcomes with Program Specific Outcomes:

CO / PSO	PSO1	PSO2	PSO3
CO1	3	3	3
CO2	3	3	3
CO3	3	3	3
CO4	3	3	3
CO5	3	3	3

UNIT - I

Introduction to Research: Definition, history, evolution, and types of research. Scientific inquiry and research ethics. Characteristics of good research and the research process.

UNIT - II

Research Problem and Design: Identifying and formulating research problems, setting objectives, and conducting literature reviews. Basics of research design and types.

UNIT - III

Measurement and Data Collection: Concepts of measurement and scaling, types of data, measurement errors, and scale construction. Data collection methods: questionnaires, interviews, and observation.

UNIT - IV

Sampling and Data Preparation: Sampling techniques, sample size, and types of sampling. Data editing, coding, and preparation for analysis.

UNIT - V

Data Analysis and Interpretation: Hypothesis testing (parametric & non-parametric), tools for analysis, and data visualization techniques such as charts, graphs, and box plots.

Text Books:

1. Dr. C.R. Kothari, Research Methodology & Business Research (2024), Galgotia Publishing Company, ISBN: 978-93-90980-48-2.
2. Dr. Zillur Rahman, Business Research Methods, McGraw Hill Education, ISBN: 978-9390177530

Reference Books:

1. J.K. Sachdeva, Business Research Methodology (2024), Himalaya Publishing House, ISBN: 978-9352625925
2. H.K. Dangi & Shruti Dewen, Business Research Methods (2024), Vikas Publishing House (Imprint of S. Chand Publishing), 2nd Edition, ISBN: 978-9359307107.

Web Links:

1. https://onlinecourses.swayam2.ac.in/cec20_mg14/preview
2. <https://archive.nptel.ac.in/courses/110/107/110107080/>

Relevant cases have to be discussed in each unit and in examination case is compulsory from any unit.

STRATEGIC MANAGEMENT

Course Code: 2505BB60

L	T	P	C
2		1	3

Course Outcomes:

At the end of the Course, Student will be able to:

- CO1:** Elaborate the basic concepts and characteristics of Strategic management.
- CO2:** Build skills to develop strategic vision, mission objectives.
- CO3:** Develop knowledge on types of strategies to implement.
- CO4:** Build awareness on various strategy evaluation and controlling approaches
- CO5:** Visualize various strategies for managing global competition

Mapping of Course Outcomes with Program Outcomes:

CO / PO	PO1	PO2	PO3	PO4	PO5	PO6	PO7	PO8	PO9	PO10	PO11
CO1	3	2	2	2	2	1	2	2	2	2	1
CO2	3	2	3	2	2	2	2	2	2	2	1
CO3	3	2	3	2	2	2	3	1	2	2	1
CO4	3	2	3	2	2	3	2	1	2	2	1
CO5	2	2	3	2	2	2	3	2	2	2	1

Mapping of Course Outcomes with Program Specific Outcomes:

CO / PSO	PSO1	PSO2	PSO3
CO1	3	2	2
CO2	3	2	2
CO3	3	2	2
CO4	3	2	2
CO5	2	3	2

UNIT – I

Strategic Planning: Definition, importance, and characteristics of strategic decisions. Difference between policy, strategy, and tactics. Strategic planning vs. long-range planning. Overview of strategic management process.

UNIT – II

Strategy Formulation: Mission, vision, and goal setting. Business environment analysis: External and Internal, Strategic analysis tools: BCG Matrix, Ansoff’s Product-Market Matrix. Long-term strategy formulation: Market development, product development, diversification, integration, and liquidation.

UNIT – III

Strategy & Corporate Restructuring Implementation: Strategy and structure, managing strategic change, strategic control mechanisms. Management tools: Benchmarking, Reengineering, Balanced Scorecard. Corporate restructuring: Mergers, acquisitions, joint ventures, and strategic alliances.

UNIT – IV

Strategic Evaluation and Control: Strategic controls, performance benchmarking, strategic information systems. Strategy evaluation tools: Strategic audit, feedback mechanisms. Corporate governance and ethical considerations in strategy.

UNIT – V

Global Issues in Strategic Management: Challenges and opportunities in international business strategy. Advantages & disadvantages of global operations. International taxation and regulatory frameworks. Role of global institutions in strategic decision-making.

Text Books:

1. Fred R. David & Forest R. David, Strategic Management: A Competitive Advantage Approach Pearson (2023), 18th Edition, ISBN:9789361590955
2. Arthur A. Thompson et al., Crafting and Executing Strategy (2021), McGraw Hill, 22nd Edition, ISBN: 978-9354600043

Reference Books:

1. Azhar Kazmi, Strategic Management and Business Policy (2021) McGraw Hill, 4th Edition, ISBN: 978-9339221836
2. Lawrence R. Jauch & William F. Glueck, Business Policy and Strategic Management (2004) McGraw Hill, 5th Edition, ISBN: 978-0070323476

Web Links:

1. <http://tjsec.digimat.in/nptel/courses/video/110108047/L21.html>
2. <https://archive.nptel.ac.in/courses/110/108/110108047/>

Relevant cases have to be discussed in each unit and in examination case study is compulsory from any unit.

LOGISTICS AND SUPPLY CHAIN MANAGEMENT

Course Code: 2505BB11

L	T	P	C
2		1	3

Course Outcomes:

At the end of the Course, Student will be able to

- CO1:** Explain the concepts of logistics and supply chain management
- CO2:** Explore the characteristics of different modes of transportation and their roles in the supply chain.
- CO3:** Identify the benefits and constraints of containerization.
- CO4:** Familiarize with essentials and types of packing and packaging.
- CO5:** Summarize the concepts of import and export logistics

Mapping of Course Outcomes with Program Outcomes:

CO / PO	PO1	PO2	PO3	PO4	PO5	PO6	PO7	PO8	PO9	PO10	PO11
CO1	3	3	3	3	3	3	3	3	3	3	3
CO2	3	3	3	3	3	3	3	3	3	3	3
CO3	2	2	2	1	1	1	1	1	2	1	1
CO4	2	2	2	1	1	1	1	1	2	1	1
CO5	2	2	2	2	1	1	2	1	2	2	2

Mapping of Course Outcomes with Program Specific Outcomes:

CO / PSO	PSO1	PSO2	PSO3
CO1	3	2	2
CO2	3	2	2
-CO3	2	2	2
CO4	2	2	2
CO5	3	2	3

UNIT – I

Logistics Management and Supply Chain Management - Definition, evolution, and importance of logistics and supply chain management. Key drivers and logistics relationships in supply chain operations.

UNIT – II

Basics of Transportation- Transportation principles and functions. Multimodal transport: characteristics and comparisons of different modes (air, ocean, road, and rail). International shipping and types of ships.

UNIT – III

Containerization: Concept, classification, and advantages of containerization. Inland Container Depots (ICDs): roles, functions, and export clearance. Role of CONCOR and Container Freight Stations (CFS).

UNIT – IV

Packing and Packaging: Functions and essentials of packing and packaging for storage and transportation. Types of packaging (primary, secondary, tertiary). Modern packaging technologies: barcodes, electronic data interchange (EDI), and universal product codes.

UNIT – V

Special Aspects of Export Logistics: Export logistics: picking, packing, customs clearance, documentation, and shipment processes. Import logistics: bonded warehousing, valuation, and customs formalities.

Text Books:

1. Martin Christopher, Logistics and Supply Chain Management (2022) Pearson, 6th Edition, ISBN: 9781292416182
2. Sunil Chopra & Peter Meindl, Supply Chain Management: Strategy, Planning, and Operation (2022) Pearson, 7th Edition, ISBN: 978-9353065966

Reference Books:

1. S.K. Bhattacharyya, Logistics Management Pearson (2020), 1st Edition, ISBN: 9788121928854
2. Michael H. Hugos, Essentials of Supply Chain Management (2018) Wiley, 4th Edition, ISBN: 9781119461104

Web Links:

1. <https://archive.nptel.ac.in/courses/110/105/110105141/>
2. <https://www.youtube.com/watch?v=Nrl0CtS1mY>

Relevant cases have to be discussed in each unit and in examination case study is compulsory from any unit.

INTELLECTUAL PROPERTY RIGHTS

L	T	P	C
2		1	3

Course Code: 2505BB52

Course Outcomes:

At the end of the Course, Student will be able to:

- CO1:** Compare different IP laws and need for protecting
- CO2:** Explain different theories on the concept of property
- CO3:** Identify various functions of WIPO
- CO4:** Analyze the IP laws in India
- CO5:** Differentiate various forms of IPR

Mapping of Course Outcomes with Program Outcomes:

CO / PO	PO1	PO2	PO3	PO4	PO5	PO6	PO7	PO8	PO9	PO10	PO11
CO1	2	2	1	3	2	2	1	1	2	2	2
CO2	2	2	1	2	1	1	1	1	1	1	1
CO3	2	2	2	2	2	2	1	2	1	1	1
CO4	2	2	1	3	3	2	2	2	2	2	2
CO5	2	2	1	3	2	2	1	1	1	1	2

Mapping of Course Outcomes with Program Specific Outcomes:

CO / PSO	PSO1	PSO2	PSO3
CO1	2	3	2
CO2	2	2	1
CO3	2	2	1
CO4	3	2	2
CO5	3	3	2

UNIT – I

Introduction: Origin and Development of IPR – Historical and theoretical basis for protection of IPR – Analyzing and understanding the Interpretation of IP laws – Need for Protecting IP

UNIT – II

Theories on concept of property – Nature – Public vs. Private – Tangible vs. Intangible – Industrial vs. Intellectual

UNIT – III

International IP Regime: World Intellectual Property Organization (WIPO) – Functions of WIPO – Membership – GATT Agreement – Major Conventions on IP – Berne Convention – Paris Convention – TRIPS agreement.

UNIT – IV

Indian IP Regime: Overview of IP laws in India – Major IP Laws in India – International treaties signed by India. IPR and Constitution of India.

UNIT – V

Forms of IPR: Forms of IPR – Copyright – Trademark – Patents – Industrial Designs – Trade Secrets – Geographical Indications - Application of different forms of IPR.

Text Books:

1. N.K. Acharya, Text Book of Intellectual Property Rights (2025) Asia Law House, 9th Edition, ISBN: 978-93-90912-20-9
2. Mainak Ghosh and others, Textbook on Intellectual Property Rights (2025) Kalyani Publishers, New Delhi, India 1st Edition, ISBN: 978-93-6440-257-6

Reference Books:

1. Rajni Malhotra Dhingra and Nisha Dhanraj Dewani, Intellectual Property Rights and Competition Law in India (2025) Routledge, ISBN: 978-1032733258
2. Nard, CraigAllen, Law of Intellectual Property- Aspen Publishers, 2nd edition I SBN-10. 0735579156; ISBN-13. 978-0735579156

Web Links:

- 1 https://onlinecourses.nptel.ac.in/noc22_hs59/preview2
- 2 <https://archive.nptel.ac.in/courses/110/105/110105139/>

Relevant cases have to be discussed in each unit and in examination case study is compulsory from any unit.

PROJECT MANAGEMENT

Course Code: 2505BB32

L	T	P	C
2		1	3

Course Outcomes:

At the end of the Course, Student will be able to:

- CO1:** Explain the basic concepts of project Management
- CO2:** Estimate project planning and risk.
- CO3:** Interpret project financing through techniques
- CO4:** Analyze the concept of Project controlling
- CO5:** Summarize stress management, conflict management and team building

Mapping of Course Outcomes with Program Outcomes:

COs / POs	PO1	PO2	PO3	PO4	PO5	PO6	PO7	PO8	PO9	PO10	PO11
CO1	3	2	1	2	2	1	1	2	2	2	1
CO2	3	3	2	1	2	1	1	1	2	2	1
CO3	2	3	2	1	2	1	1	1	2	2	2
CO4	3	3	2	1	3	1	1	1	1	3	2
CO5	2	2	2	2	2	2	3	3	2	2	2

Mapping of Course Outcomes with Program Specific Outcomes:

CO / PSO	PSO1	PSO2	PSO3
CO1	3	2	1
CO2	3	3	2
CO3	3	3	2
CO4	3	2	2
CO5	2	2	2

UNIT – I

Introduction to Project Management: Project Characteristics – Project Life Cycle – Project Identification, Formulation and Implementation – Project Management in Different Sectors, Systems Approach to Project Management

UNIT – II

Project Appraisal: Project Planning – Steps in Project Planning – Scheduling – Project Appraisal – Feasibility Study – Technical, Commercial, Economic, Financial, Management, Social, Cost Benefit Analysis – Project Risk Analysis

UNIT – III

Project Finance: Project Cost Estimation, Project Financing – Investment Criteria, Project Evaluation Techniques –Cash Flows Estimation for New and Replacement Projects – Cost of Capital, Risk Analysis.

UNIT – IV

Project Control: Network Diagrams, Network Analysis, Critical Path, Quality Management, Project Execution, Monitoring and Control, Agile Project Management, Scrum, Lean Production.

UNIT – V

Organizational Behavior and Project Management: Structure & Integration, Project Manager & Team Role, Stakeholder Engagement, Leadership, Conflict & Stress Management in Projects.

Text Books:

1. Erik W. Larson & Clifford F. Gray, Project Management: The Managerial Process McGraw Hill (2022), 8th Edition, ISBN: 978-9354602078
2. A Guide to the Project Management Body of Knowledge (PMBOK Guide) (2021)– Project Management Institute, 7th Edition, ISBN: 978-1628256659

Reference Books:

1. K. Nagarajan, Project Management (2020) New Age International, 9th Edition ISBN: 9789360748531
2. Harold Kerzner, Project Management: A Systems Approach (2017) Wiley, 12th Edition 2017 ISBN: 9781119165354

Web Links:

1. https://onlinecourses.nptel.ac.in/noc23_mg124/preview
2. https://onlinecourses.nptel.ac.in/noc24_mg01/preview

Relevant cases have to be discussed in each unit and in examination case study is compulsory from any unit.

BUSINESS TAXATION

Course Code: 2505BB18

L	T	P	C
2	1		3

Course Outcomes:

At the end of the Course, Student will be able to:

- CO1:** Explain the concept, structure, and components of GST within the Indian tax framework including registration processes and related constitutional provisions.
- CO2:** Describe the scope of supply, levy, composition scheme, input tax credit, and tax payment processes under GST.
- CO3:** Apply the procedures for filing GST returns, conducting audits, and handling assessments using Tally ERP and the GST portal.
- CO4:** Apply practical skills to configure, record, and file GST transactions and returns using accounting software like Tally ERP.
- CO5:** Analyze the provisions of customs law, types of duties, and procedures related to import/export, valuation, and duty drawbacks under the 2017 customs rules.

Mapping of Course Outcomes with Program Outcomes:

COs / POs	PO1	PO2	PO3	PO4	PO5	PO6	PO7	PO8	PO9	PO10	PO11
CO1	3	2	1	2	2	3	2	1	2	2	2
CO2	2	3	2	1	2	2	2	2	1	2	1
CO3	2	3	2	1	2	3	1	1	2	2	2
CO4	3	3	3	1	2	2	2	2	2	1	2
CO5	3	2	2	2	2	2	2	1	2	2	2

Mapping of Course Outcomes with Program Specific Outcomes:

CO / PSO	PSO1	PSO2	PSO3
CO1	3	2	1
CO2	2	2	2
CO3	2	2	2
CO4	3	3	2
CO5	3	2	2

UNIT - I

Introduction to GST and Tax Framework: Overview of GST, need and objectives, Constitution (101st Amendment) Act 2016, structure of Indian taxation – direct vs. indirect taxes, GST Council, tax rates, dual model of GST, CGST, SGST, UTGST, IGST, GSTN. GSTIN, process of registration and types – compulsory, exemption, cancellation, revocation.

UNIT - II

Supply, Levy and Input Tax Credit: Meaning and scope of supply – composite and mixed supplies. Levy and collection of GST, composition scheme, time and value of supply. Input Tax Credit (ITC) – eligibility, distribution, documentation (invoices, credit/debit notes, vouchers). Payment of tax – ledgers, challans, timelines, interest, set-off and refund process.

UNIT - III

GST Returns and Audit: Types of GST returns – GSTR-1 to GSTR-11. Audit under Sections 65 & 66, departmental audits, audit procedure, findings, and response. Assessment, demand and recovery rules. Practical work on GST registration, return filing, and tax payment using Tally ERP and GST portal.

UNIT - IV

Practical Applications of GST: Hands-on training in GST setup using accounting software (Tally ERP). Defining GST rates at master and transaction levels, creating GST ledgers, accounting GST transactions, generating and exporting GSTRs, and filing them online.

UNIT - V

Basics of Customs Duty: Introduction to customs law, territorial waters, types of duties – basic, protective, countervailing, safeguard, anti-dumping. Concepts like baggage rules, warehousing, export procedure, deemed exports, duty drawback, and valuation of import/export goods under 2017 customs rules.

Text Books:

1. Akhileshwar Pathak & Savan Godiawala, Business Taxation McGraw-Hill Education India, and Print ISBN: 978-1259098024, eText ISBN: 978-1259098017.
2. CA Raj K. Agrawal, Handbook on Income Tax (A.Y. 2025–2026) Bharat Law House Pvt. Ltd. ISBN: 978-93-4808-017-2

Reference Books:

1. Dr. Girish Ahuja & Dr. Ravi Gupta, Systematic Approach to Income Tax (Golden Jubilee Edition 2025) Commercial Law Publishers, ISBN: 978-93-5603-720-5.
2. A.N. Aiyar's Indian Tax Law, 2025, Company Law Institute, ISBN: 978-93-5569-443- 0.

Web Links:

1. <https://www.youtube.com/watch?v=swrzarYcMvY>
2. https://www.youtube.com/watch?v=QUI_OevD3yw

Relevant cases have to be discussed in each unit and in examination case study is compulsory from any unit.

**PROGRAM ELECTIVE COURSES COURSE 1: FINANCE (FIN)
 FINANCIAL MARKETS, PRODUCTS AND SERVICES**

Course Code: 2505BB25

L	T	P	C
2		1	3

Course Outcomes:

At the end of the Course, Student will be able to:

- CO1:** Describe the structure and functions of the Indian financial system and its various components.
- CO2:** Explain the operations of capital and money markets, including instruments, trading mechanisms, and regulatory frameworks.
- CO3:** Analyze different financing options such as leasing, hire purchase, and installment systems.
- CO4:** Evaluate mutual fund schemes and credit rating processes to assess their suitability for investment decisions.
- CO5:** Compare and interpret factoring, forfaiting, and bill discounting mechanisms in the context of short-term finance.

Mapping of Course Outcomes with Program Outcomes:

CO / PO	PO1	PO2	PO3	PO4	PO5	PO6	PO7	PO8	PO9	PO10	PO11
CO1	3	2	2	2	2	1	1	1	1	1	2
CO2	3	3	3	3	3	2	1	1	1	1	2
CO3	3	3	3	2	2	3	2	1	1	2	2
CO4	3	3	3	2	2	3	2	2	1	1	2
CO5	3	3	2	2	2	3	1	2	1	2	1

Mapping of Course Outcomes with Program Specific Outcomes:

CO / PSO	PSO1	PSO2	PSO3
CO1	3	2	2
CO2	3	3	2
CO3	3	3	2
CO4	3	3	2
CO5	3	3	2

UNIT-I:

Financial System and Markets: Financial System – Need, Structure, Functions, Scope, Financial Intermediation, Fund-based and Fee-based Products, Money Market – Instruments (T-Bills, CPs, CDs, Call Money, Mutual Funds, Bills), Trading Mechanism, Capital Market – Functions, Primary and Secondary Markets, Methods of Floatation (IPO, Book Building, Rights, Bonus Issue), Investor Protection, Recent Trends, SEBI – Objectives, Role, Functions, Powers

UNIT-II:

Stock Exchanges and Trading Mechanisms: Major Stock Exchanges – NSE, BSE, Stock Market Indices – Purpose and Development Methods, Stock Trading – Brokers, Types of Orders, Trading Systems (BOLT, NEAT), Trading Cycle (T+2), Settlements (Demat, Physical), Circuit Breakers, Market Makers

UNIT-III:

Leasing, Hire Purchase and Installment Finance: Leasing – Definition, Types, Features, Advantages/Disadvantages, Lease Agreement Clauses, Buy or Lease Decision, Lease Evaluation (Lessee’s and Lessor’s Perspective), Hire Purchase – Concept, Features, Evaluation, Comparison with Leasing, Installment Purchase – Meaning and Differences

UNIT-IV:

Mutual Funds and Credit Rating: Mutual Funds – Definition, Types, Structure (Trustee, Sponsor, AMC, Custodian), Entry/Exit Loads, NAV, SIP, SWP, Regulations, Industry Overview, Credit Rating – Meaning, Process, Methodology, Major Agencies, Rating Symbols, Advantages/Disadvantages

UNIT-V:

Factoring, Forfaiting and Bill Discounting: Factoring – Types (Domestic, International, Export, Import, Recourse, Non-recourse), Fees, Advantages/Disadvantages, Bill Discounting – Definition, Types, Comparison with Factoring, Rediscounting, Forfaiting – Mechanism, Fees, Advantages, Differences with Factoring, Numerical Problems – Leasing and Hire Purchase

Text Books:

1. Dr. Sudha, Financial Markets and Services, Publisher: Sultan Chand & Sons, ISBN: 93- 91820-92-3
2. Dr. Purushottam Arvind Petare, Dr. N. Sujatha, Dr. Shyma K, Anshuman Vijay Magar, Dr. S. Saravanan, Financial Markets and Services, RED'SHINE Publication Pvt. Ltd. ISBN: 978-93-954569-9-9

Reference Books:

1. Clifford Gomez, Financial Markets, Institutions, and Financial Services (2025) PHI Learning, ISBN: 978-81-203-3537-0
2. Clifford Gomez – Financial Markets, Institutions and Financial Services (2024), PHI Learning, 1st Edition, ISBN-10: 8124333429, ISBN-13: 978-8178333427

Web Links:

1. NPTEL - Financial Markets
2. NPTEL - Financial Markets and Services

Relevant cases have to be discussed in each unit and in examination case study is compulsory from any unit.

BUSINESS ANALYSIS AND VALUATION

Course Code: 2505BB16

L	T	P	C
2		1	3

Course Outcomes:

At the end of the Course, Student will be able to:

- CO1:** Explain the concepts of market value, book value, and various valuation methods including equity, debt, and enterprise valuation.
- CO2:** Apply Discounted Cash Flow (DCF) methods to estimate firm value using appropriate discount rates and cash flow projections.
- CO3:** Analyze relative valuation approaches using financial ratios and assess comparable companies for benchmarking.
- CO4:** Evaluate the impact of corporate restructuring strategies on firm valuation, including the effect of synergies and control premiums.
- CO5:** Assess challenges and complexities involved in valuation during restructuring and practice valuation techniques in restructuring contexts.

Mapping of Course Outcomes with Program Outcomes:

CO / PO	PO1	PO2	PO3	PO4	PO5	PO6	PO7	PO8	PO9	PO10	PO11
CO1	3	2	2	1	1	2	1	1	1	1	1
CO2	3	3	3	2	2	2	1	1	1	1	2
CO3	3	3	3	2	2	3	1	1	1	2	1
CO4	3	3	3	3	2	3	1	2	1	2	2
CO5	3	3	3	3	2	3	1	2	1	2	2

Mapping of Course Outcomes with Program Specific Outcomes:

CO / PSO	PSO1	PSO2	PSO3
CO1	3	2	1
CO2	3	3	2
CO3	3	3	2
CO4	3	3	2
CO5	3	3	2

UNIT-I

Introduction to Valuation: Market Value vs Book Value, Valuation of Equity and Debt, Enterprise Valuation, Discounted Cash Flow Methods vs Relative Valuation, Challenges in Valuation Methods

UNIT-II

Discounted Cash Flow Valuation (DCF): FCFE vs FCFE Methods, Appropriate Discount Rates, Cost of Equity – Unlevered vs Levered Beta, Risk-Free Rate and Market Risk Premium, Cost of Debt – Risk-Free Rate and Credit Risk Premium, Tax Rate Assumptions for Growth, Estimating Cash Flows, Impact of Non-Cash Expenses: Depreciation, Taxes, Forecasting Cash Flows, Perpetual Growth Rate and Terminal Value, Role of Comparable Companies in Choosing Growth Rates and Discount Rates, Challenges in Using DCF Valuation Methods

UNIT-III

Relative Valuation: Relative Valuation Ratios: P/E Ratio, P/B Ratio, EV/EBITDA, Evaluating Comparable Companies, Challenges in Using Relative Valuation, Practice Exercises

UNIT-IV

Corporate Restructuring: Definition of Restructuring, Organic vs Inorganic Growth, Bankruptcy and its Impact on Cash Flows and Discount Rates, Premium for Control in Privately Held Firms, Accounting for Synergies – Revenue Growth or Expense Reduction

UNIT-V

Valuation in Corporate Restructuring: Impact of Corporate Restructuring on Valuation, Evaluating Synergies – Types of Synergies (Revenue vs Cost Synergies), Challenges in Assessing Synergies, Role of Premium for Control in Restructuring Deals, Practice Exercises on Restructuring and Valuation

Text Books:

1. Krishna G. Palepu & Paul M. Healy, Business Analysis and Valuation: Using Financial Statements Publisher: Cengage Learning India, 5th Edition, ISBN: 978-8131526644
2. Krishna G. Palepu & Paul M. Healy, Business Analysis and Valuation: Using Financial Statements (IFRS Edition), Cengage Learning India, ISBN: 978-1408017494

Reference Books:

1. Corporate Professionals, Business Valuation in India: Beyond the Numbers (2025) Commercial Law Publishers (India) Pvt. Ltd., 3rd Edition, ISBN: 978-9356036819
2. McKinsey & Company Inc. Publisher: Valuation: Measuring and Managing the Value of Companies (2025), Wiley, 8th Edition, ISBN: 978-1394279418

Web Links:

1. Investopedia - Discounted Cash Flow (DCF) Valuation
2. Aswath Damodaran's Online Valuation Resources

Relevant cases have to be discussed in each unit and in examination case study is compulsory from any unit.

FINANCIAL PLANNING

Course Code: 2505BB26

L	T	P	C
2		1	3

Course Outcomes:

At the end of the Course, Student will be able to:

- CO1:** Explain the fundamentals of financial planning, including goal setting, budgeting, cash flow, debt management, and time value of money.
- CO2:** Analyze various investment options and assess their risk-return characteristics in alignment with financial goals and personal risk profiles.
- CO3:** Evaluate different retirement planning schemes and their integration with tax-saving strategies to ensure financial security post-retirement.
- CO4:** Interpret the principles of insurance and estate planning to manage financial risks and plan for wealth transfer effectively.
- CO5:** Develop a comprehensive personal financial plan by integrating investment, risk, retirement, and tax considerations for various profiles.

Mapping of Course Outcomes with Program Outcomes:

CO / PO	PO1	PO2	PO3	PO4	PO5	PO6	PO7	PO8	PO9	PO10	PO11
CO1	3	3	2	2	2	3	2	1	1	1	1
CO2	3	3	2	2	2	3	2	1	1	1	1
CO3	3	2	3	2	2	3	3	1	1	1	1
CO4	3	3	2	2	2	3	3	2	1	1	1
CO5	3	3	2	2	2	3	3	2	1	1	1

Mapping of Course Outcomes with Program Specific Outcomes:

CO / PSO	PSO1	PSO2	PSO3
CO1	3	3	2
CO2	3	3	2
CO3	3	3	2
CO4	3	3	2
CO5	3	3	2

UNIT-I

Introduction to Financial Planning: Social, political, and economic environment analysis, psychological and financial needs assessment, identifying financial goals, types of goals, financial discipline, steps in financial planning, budgeting, cash flow, and debt management, risk-return analysis, time value of money, life cycle approach to financial planning, assessing individual risk-taking level.

UNIT-II

Investment Planning: Definition and need for investment, investment vs. speculation vs. gambling, principles of investing, risk and return measurement, popular investment avenues (stocks, bonds, mutual funds, gold, real estate, ULIPs), risk-return computation, diversification, mapping investment with goals, cultural perspectives on investment behavior, types of credit, cost of credit, CIBIL score, signs of over-indebtedness.

UNIT-III

Retirement Planning: Principles, stages and steps in retirement planning, various retirement schemes – Employee Provident Fund, Public Provident Fund, Superannuation Fund, Gratuity, National Pension Scheme, Old Pension Scheme, other pension plans, tax planning: importance, tax saving under section 80C and others, linkage of tax planning and retirement planning, effect of cultural perspectives on retirement planning.

UNIT-IV

Insurance and Estate Planning: Insurance Planning: meaning, risk management, risk exposures, role of insurance company in advisor selection, various strategic solutions for insurance planning, estate planning terminology, process of estate planning, wealth distribution goals, strategies for estate planning.

UNIT-V

Practical Orientation and Financial Plan Preparation: Prepare a financial plan for a person/manager/entrepreneur/director/CEO of a company/bank/insurance agent, considering his/her current expense level, future needs, investment, risk management, retirement, and tax planning goals.

Text Books:

1. Anandi Sahu, Financial Planning: Theory and Practice (August 7, 2024), Atlantic Publishers and Distributors, ISBN-13: 978-8126940356
2. Dr. Shalu Garg, Personal Financial Planning (2024), Sultan Chand & Sons, ISBN: 93-91820-90-9

Reference Books:

1. Practicing Financial Planning: For Professionals and CFP® Aspirants by Indian Institute of Banking & Finance, Publisher: Taxmann Publications, ISBN-13: 978-9386042859
2. All About FP&A by CA Asif Masani, Publisher: Not specified, Publication Date: January 10, 2025, ISBN-13: 978-9393635969

Web Links:

1. Coursera Wharton Business Financial Modeling
2. NPTEL Financial Planning Course

Relevant cases have to be discussed in each unit and in examination case study is compulsory from any unit.

SUSTAINABLE FINANCE

Course Code: 2505BB39

L	T	P	C
2		1	3

Course Outcomes:

At the end of the Course, Student will be able to:

- CO1:** Explain the impact of climate change on financial systems and analyze climate finance mechanisms including mitigation and adaptation strategies.
- CO2:** Evaluate ESG models and assess the viability of sustainable investment opportunities using ethical and financial criteria.
- CO3:** Interpret carbon credit mechanisms, global carbon markets, and emission trading frameworks in the context of financial management.
- CO4:** Examine sustainable reporting standards and disclosure frameworks, including GRI, ESG, and integrated reporting practices.
- CO5:** Apply sustainable finance tools in real-world scenarios and assess emerging trends, legal challenges, and ESG adoption by industries.

Mapping of Course Outcomes with Program Outcomes:

CO / PO	PO1	PO2	PO3	PO4	PO5	PO6	PO7	PO8	PO9	PO10	PO11
CO1	3	3	2	2	3	2	2	3	3	2	3
CO2	3	3	3	2	3	2	3	3	3	2	3
CO3	3	3	3	2	3	2	2	3	3	2	3
CO4	3	3	2	3	3	2	2	3	3	2	2
CO5	3	3	3	2	3	3	3	3	3	3	3

Mapping of Course Outcomes with Program Specific Outcomes:

CO / PSO	PSO1	PSO2	PSO3
CO1	3	2	3
CO2	3	3	3
CO3	3	3	3
CO4	3	3	3
CO5	3	3	3

UNIT-I

Climate Change and Finance: Sustainable development goals, climate finance strategies (reduction, adaptation), renewable energy finance, global environmental politics, climate finance impacts on industries, financial tools (subsidized finance, securities), climate risk, and equity valuation.

UNIT-II

Sustainable Finance: ESG model components, ethical investment approaches, ESG evaluations, investment opportunities (stocks, bonds, mutual funds), portfolio analysis for ESG, comparison with traditional portfolios, sustainable capital asset pricing, blue economy sectors, and small nation economies.

UNIT-III

Carbon Credit and Mechanism: Carbon credit essentials, carbon pricing and markets, Kyoto and Paris agreements, EU-ETS, voluntary carbon market, carbon offsetting mechanisms, CORSIA, emission trading in India, ESCerts, future of carbon trading.

UNIT-IV

Sustainable Reporting and Disclosure Practices: Sustainability reporting drivers, GRI, responsible investment, integrated reporting, circular economy principles, ESG disclosures, greenwashing, and comparison of ESG, SRI, and impact investing frameworks.

UNIT-V

Practical Applications and Future Trends: Applying sustainable finance tools, carbon trading in industries, legal challenges in climate finance, future of sustainable finance, ESG adoption by corporations, emerging trends in sustainability finance.

Text Books:

1. Biswadeep Mishra & Aakash Sharma, Sustainable Finance Book (April 2025), Bloomsbury India, 1st Edition, and ISBN: 978-93-6131-993-8.
2. Dirk Schoemaker, Principles of Sustainable Finance (2021) Oxford University Press.

Reference Books:

1. Shakeb Akhtar, Mahfooz Alam, Nassir Ul Haq Wani, and Syed Hasan Jafar, Green Horizons: Role of AI in Sustainable Finance (2025), Springer ISBN: 978-981-966494-8.
2. Vikas Sharma, Tejinder Singh, Andreia de Bem Machado, Ramona Rupeika-Apoga, FinTech for Sustainable Finance and a Well-Blue Economy (Forthcoming August 2025) Springer, ISBN: 978-3-031-92389-0.

Web Links:

1. Coursera - Wharton Business: Financial Modeling and Sustainable Finance
2. NPTEL - Course on Climate Finance and Sustainability

Relevant cases have to be discussed in each unit and in examination case study is compulsory from any unit.

**COURSE 2: MARKETING (MKTG)
SALES MANAGEMENT**

Course Code: 2505BB37

L T P C
2 1 3

Course Outcomes:

At the end of the Course, Student will be able to:

- CO1:** Explain the role, scope, and process of sales management and its significance in modern businesses.
- CO2:** Design effective recruitment, training, and organizational plans for managing a sales force.
- CO3:** Develop strategies to motivate, compensate, and direct sales teams effectively.
- CO4:** Analyze and evaluate sales performance using sales budgeting, profitability analysis, and territory management.
- CO5:** Formulate sales control mechanisms and develop actionable sales plans to enhance sales effectiveness.

Mapping of Course Outcomes with Program Outcomes:

CO / PO	PO1	PO2	PO3	PO4	PO5	PO6	PO7	PO8	PO9	PO10	PO11
CO1	3	3	2	2	2	3	2	-	-	-	-
CO2	3	3	2	2	2	3	2	-	-	-	-
CO3	3	3	3	2	2	3	2	-	-	-	-
CO4	3	3	3	3	2	3	2	-	-	-	-
CO5	3	3	3	3	2	3	2	-	-	-	-

Mapping of Course Outcomes with Program Specific Outcomes:

CO / PSO	PSO1	PSO2	PSO3
CO1	3	3	2
CO2	3	3	2
CO3	3	3	2
CO4	3	3	2
CO5	3	3	2

UNIT-I

Introduction to Sales Management: Meaning, nature, and importance of sales management in modern businesses, roles and responsibilities of the sales manager, personal selling and salesmanship, the selling process.

UNIT-II

Organizing the Sales Force: Recruiting sales personnel, planning, sources, selecting sales personnel, executing and evaluating sales training programs, sales information systems and planning, sales skills.

UNIT-III

Directing Sales Force Operations: Motivating sales personnel, designing and administering compensation plans (financial and non- financial compensation methods), sales meetings, contests, and quotas, defining and managing sales territories.

UNIT-IV

Evaluating Sales Force Performance: The sales budget, analysis of sales volume and profitability, evaluating salesperson performance, using selling agents for internet trading.

UNIT-V

Sales Force Control and Management: Controlling sales activities, sales performance monitoring, and strategies for enhancing sales effectiveness, developing and managing sales plans.

Text Books:

1. S.A. Chunawalla, Sales Management (2025), Himalaya Publishing House, 8th Edition, ISBN: 978-93-5367-464-9
2. Shane Hunt, George Deitz, and John Hansen, Professional Selling (2024 Release) McGraw Hill, ISBN: 978-1264459896

Reference Books:

1. Bill Donaldson, Javier Marcos Cuevas, and Régis Lemmens, Sales Management: Strategy, Process and Practice Red Globe Press (Bloomsbury Publishing), 4th Edition, ISBN: 978- 9356403260
2. Thomas N. Ingram, Sales Management: Analysis and Decision Making (2024) Taylor & Francis, 11th Edition, ISBN: 978-1032426358

Web Links:

1. Sales Management - Coursera
2. Sales Management Course – edX

Relevant cases have to be discussed in each unit and in examination case study is compulsory from any unit.

RETAIL MARKETING

Course Code: 2505BB34

L	T	P	C
2		1	3

Course Outcomes:

At the end of the Course, Student will be able to:

- CO1:** Describe the fundamentals of retailing, retail formats, and consumer behavior.
- CO2:** Analyze the retail marketing mix, merchandising, and pricing strategies.
- CO3:** Evaluate retail finance, store location, and visual merchandising strategies.
- CO4:** Explain retail buying, service strategies, and digital retailing approaches.
- CO5:** Assess current trends, challenges, and sustainability issues in retailing.

Mapping of Course Outcomes with Program Outcomes:

CO / PO	PO1	PO2	PO3	PO4	PO5	PO6	PO7	PO8	PO9	PO10	PO11
CO1	3	3	3	2	2	3	3	-	-	-	-
CO2	3	3	3	3	2	3	2	-	-	-	-
CO3	3	3	3	3	2	3	2	-	-	-	-
CO4	3	3	3	3	2	3	2	-	-	-	-
CO5	3	3	3	3	2	3	2	-	-	-	-

Mapping of Course Outcomes with Program Specific Outcomes:

CO / PSO	PSO1	PSO2	PSO3
CO1	3	3	2
CO2	3	3	2
CO3	3	3	2
CO4	3	3	2
CO5	3	3	2

UNIT-I

Introduction to Retailing and Consumer Behavior: Introduction to retailing, retailing theories, emerging trends, evolution in India, factors behind industry change, retail formats (ownership, store-based, web, non-store), consumer behavior analysis.

UNIT-II

Retail Marketing and Merchandising: Retail marketing mix, advertising & promotion, store positioning, merchandising management, pricing strategies, merchandise pricing, mark-up/markdown, people strategy in retail.

UNIT-III

Retail Finance and Location Strategy: Retail finance strategy, store location strategy, trading-area analysis, site selection, store planning, design/layout, visual merchandising, and space management.

UNIT-IV

Buying, Merchandising, and Services in Retail: Buying and merchandising management, service strategies in retail, relationship marketing, digital strategies, online retailing.

UNIT-V

Contemporary Issues in Retailing: Current retail trends, challenges of traditional vs. e-commerce, technology and digital transformation, future trends in retail, sustainability and cultural factors in retail.

Text Books:

1. Dr. Pandian Sundara P & Dr. Muthulakshmi S, Retail Management: A Global Perspective (2025), Sultan Chand & Sons ISBN: 978-93-91820-58-9.
2. Sarah Montano, Retail Marketing: Contemporary Approaches to Retailing in the Digital and Experience Economy, Kogan Page Ltd, ISBN: 978-1398617636.

Reference Books:

1. Rosemary Varley & Mohammed Rafiq, Principles of Retailing, Bloomsbury Publishing Indi Pvt. Ltd, ISBN: 978-9356403307.
2. Retailing Management, Michael Levy, Barton A. Weitz, and Dhruv Grewal, McGraw Hill, 11th Edition, ISBN: 978-1264157440.

Web Links:

1. Retailing Management | NPTEL Online Course
2. Coursera - Retail Management

Relevant cases have to be discussed in each unit and in examination case study is compulsory from any unit.

INTERNATIONAL MARKETING

	L	T	P	C
Course Code: 2505BB29	2		1	3

Course Outcomes:

At the end of the Course, Student will be able to:

- CO1:** Explain the scope, challenges, and environment of international marketing, including the role of global institutions and Indian policies.
- CO2:** Apply strategic approaches to international market entry and evaluate the suitability of different entry modes.
- CO3:** Analyze product adaptation and standardization strategies and evaluate pricing decisions in global markets.
- CO4:** Develop international promotion strategies and assess their effectiveness across diverse cultural and regulatory environments.
- CO5:** Design and evaluate international distribution and logistics strategies to optimize global supply chains.

Mapping of Course Outcomes with Program Outcomes:

CO / PO	PO1	PO2	PO3	PO4	PO5	PO6	PO7	PO8	PO9	PO10	PO11
CO1	3	3	2	3	2	3	2	2	2	2	1
CO2	3	3	3	3	3	3	2	2	2	2	2
CO3	3	3	3	3	3	3	2	2	2	2	1
CO4	3	3	3	3	2	3	2	2	3	2	1
CO5	3	3	3	3	3	3	3	2	2	2	2

Mapping of Course Outcomes with Program Specific Outcomes:

CO / PSO	PSO1	PSO2	PSO3
CO1	3	3	2
CO2	3	3	2
CO3	3	3	2
CO4	3	3	2
CO5	3	3	2

UNIT-I

Introduction to International Marketing: Scope and challenges in international marketing, international marketplace, macroeconomic & microeconomic concepts, social, cultural, legal, political, and ethical considerations, economic groupings, role of governance mechanisms (WTO, World Bank, IMF), Indian international marketing policies and institutions.

UNIT- II

International Market Entry and Development: Strategic planning – assessing global markets, international market research, global market entry strategies – export/import, international intermediaries (EMC, trading companies), licensing, franchising, FDI, local presence, inter-firm cooperation, MNCs and globalization, mergers and acquisitions.

UNIT- III

Product Adaptation and Pricing Strategies in International Markets: Product standardization and adaptation, product constituents and content, brands in the international market, quality, packaging, and labelling, marketing consumer services globally, price dynamics in international markets, global pricing methods and strategies.

UNIT- IV

Promotion Strategies for International Marketing: International advertising, global sale promotion strategies, legal constraints, media channels for international advertising, designing sale force management for the international market.

UNIT- V

Distribution Strategies in International Marketing: Factors affecting the choice of distribution channels, channel management and structure, designing and managing distribution networks, global logistics, supply chain management in international marketing.

Text Books:

1. M. Billur Akdeniz, Sebastian van der Vegt, S. Tamer Cavusgil, International Marketing in a Changing World: A Managerial Guidebook, Business Expert Press, ISBN-13: 9781637428481
2. Philip R. Cateora, R. Bruce Money, Mary C. Gilly, John L. Graham, International Marketing (2024) McGraw Hill, 19th Edition ISBN-13: 9781266148637

Reference Books:

1. Dr. Prashant Gundawar, Dr. Aditya Bavadekar, Prof. Asmita Laxmikant Mudaliar, Prof. Dr. Shriram Joshi, International Marketing, San International Scientific Publication, ISBN-13: 978-81-973185-4-2
2. Dana-Nicoleta Lasca, George L. Hiller, International Marketing, Textbook MediaPress ISBN-13: 9781732242524

Web Links:

1. <https://www.coursera.org/learn/global-marketing>
2. https://onlinecourses.nptel.ac.in/noc21_mg93/preview

Relevant cases have to be discussed in each unit and in examination case study is compulsory from any unit

RURAL MARKETING

Course Code: 2505BB36

L	T	P	C
2		1	3

Course Outcomes:

At the end of the Course, Student will be able to:

- CO1:** Explain the scope, significance, and challenges of rural marketing in India.
- CO2:** Analyze rural consumer behavior and identify suitable marketing research approaches for rural markets.
- CO3:** Apply rural-specific marketing mix strategies including product, pricing, and segmentation decisions.
- CO4:** Evaluate communication and distribution strategies used in rural markets, including innovations in rural retailing.
- CO5:** Assess emerging rural marketing practices and technologies, including the integration of sustainability and digital tools.

Mapping of Course Outcomes with Program Outcomes:

CO / PO	PO1	PO2	PO3	PO4	PO5	PO6	PO7	PO8	PO9	PO10	PO11
CO1	3	2	2	2	3	2	2	-	-	-	-
CO2	3	3	2	3	3	3	2	-	-	-	-
CO3	3	3	3	3	3	3	2	-	-	-	-
CO4	3	3	3	3	2	3	3	-	-	-	-
CO5	3	3	3	3	3	3	3	-	-	-	-

Mapping of Course Outcomes with Program Specific Outcomes:

CO / PSO	PSO1	PSO2	PSO3
CO1	3	3	2
CO2	3	3	2
CO3	3	3	2
CO4	3	3	2
CO5	3	3	2

UNIT-I

Introduction to Rural Marketing: Concept and scope, attractiveness and challenges of rural markets, rural vs. urban markets, rural marketing environment, rural market in India, size and scope, emerging profile of rural markets in India, rural vs. urban marketing.

UNIT-II

Rural Consumer Behavior: Rural consumers' dimensions, buying decision process, marketing mix for rural marketing, researching rural markets, research approach, rural marketing information system, rural marketing regulation, and institutional support.

UNIT-III

Rural Marketing Strategies: Rural marketing mix, rural market segmentation, positioning strategies for rural markets, strategies for new product planning and development for rural markets, product mix, pricing strategies for rural markets, pricing policies, innovation in pricing of products.

UNIT-IV

Communication and Distribution in Rural Markets: Challenges in rural communication, advertising, and sales promotion for rural markets, rural media, branding in rural markets, issues in rural distribution channels, tapping rural markets, rural retailing, haats/shandies, vans and mobile stores, innovation in rural distribution systems.

UNIT-V

Rural Marketing Practices and Innovations: Evolving rural marketing practices, case studies on rural retailing, mobile and online retail strategies for rural markets, government policies and rural entrepreneurship, rural market research tools and technologies, future trends in rural marketing, integrating sustainability in rural marketing strategies.

Text Books:

1. Sanal Kumar Velayudhan, Rural Marketing: Growing the Non-Urban Consumer (2024), Routledge India ISBN-13: 978-1032685250
2. Deepa Gupta, Mukul Gupta, Parth Mukul Gupta, Rural Marketing and Management (2025) PHI Learning, ISBN-13: 978-8119364848

Reference Books:

1. Charles Chatterjee, Rural Marketing as a Tool for National Development, Emerald Publishing, ISBN-13: 978-1836080657
2. C. N. Sontakki, Rural Marketing: Environment and Strategy (2023), Himalaya Publishing House, ISBN-13: 978-9350223456

Web Links:

1. <https://www.coursera.org/learn/rural-marketing>
2. <https://www.nptel.ac.in/courses/110/105/110105120/>

Relevant cases have to be discussed in each unit and in examination case study is compulsory from any unit.

**COURSE-3: HUMAN RESOURCES
EMPLOYEE LIFE CYCLE MANAGEMENT**

Course Code: 2505BB24

L	T	P	C
2		1	3

Course Outcomes:

At the end of the Course, Student will be able to

- CO1:** Explain the key stages of the Employee Life Cycle (ELC) and the strategic role of HR in managing them.
- CO2:** Apply effective recruitment, onboarding, and training strategies aligned with organizational objectives.
- CO3:** Evaluate performance management systems and retention strategies to enhance employee satisfaction and engagement.
- CO4:** Assess methods for fostering employee well-being and managing work-life balance in a diverse workforce.
- CO5:** Design and improve exit management processes to support continuous organizational development and alumni engagement.

Mapping of Course Outcomes with Program Outcomes:

CO / PO	PO1	PO2	PO3	PO4	PO5	PO6	PO7	PO8	PO9	PO10	PO11
CO1	3	3	2	2	3	2	3	-	-	-	-
CO2	3	3	2	2	3	2	3	-	-	-	-
CO3	3	3	3	3	3	2	3	-	-	-	-
CO4	3	3	3	3	3	3	3	-	-	-	-
CO5	3	3	3	3	3	3	3	-	-	-	-

Mapping of Course Outcomes with Program Specific Outcomes:

CO / PSO	PSO1	PSO2	PSO3
CO1	3	3	2
CO2	3	3	2
CO3	3	3	2
CO4	3	3	2
CO5	3	3	2

UNIT-I

Introduction and Recruitment: Approaches to Employee Life Cycle Management, Erickson’s Life Stages, Nature, Scope, and Importance of ELC, Stages of ELC and Role of HR, Job Analysis and Job Design, Recruitment – Meaning, Process, Sources, Techniques, Legal Considerations in Hiring, Selection – Meaning, Steps, Types.

UNIT-II

Onboarding and Development: Placement – Definition, Objectives, Significance, Induction – Definition, Objectives, Significance, Content, Socialization – Definition, Stages, Significance, Evaluating Onboarding Effectiveness, Training – Concept, Need, Importance, Types, Identifying Training Needs, Designing and Implementing Training Programs, Techniques of Training, Competency-Based Training, Evaluating Training Effectiveness, Career Pathing and Succession Planning, Overview of Human Resource Development.

UNIT-III

Performance Management and Retention Management: Nature, Scope, Process, Objectives, Importance, Performance Appraisal – Concept, Objectives, Importance, Process, Methods, Essentials, Job Evaluation – Concept, Objectives, Process, Significance, Techniques, Limitations, Compensation Management – Concept, Components, Objectives, Methods, Incentive Compensation, Continuous Feedback, Managing Performance Issues, Retention – Concept, Objectives, Significance, Work Environment, Employee Motivation, Satisfaction, Engagement Techniques, Recognition Programs, Retention Strategies, Discipline and Grievance.

UNIT-IV

Employee Well-being: Definition and Dimensions of Employee Well-being, Impact of Well-being on Performance and Productivity, Employee Health and Wellness Programs, Work-Life Balance, Measuring and Enhancing Employee Engagement, Continuous Improvement in Well-being and Engagement.

UNIT-V

Exit Management: Exit Management – Concept, Importance, Scope, Offboarding Processes, Managing Transfers and Promotions, Conducting Exit Interviews, Analyzing Exit Data, Maintaining Alumni Relations, Employee Advocacy, Role of Communication, Managing Voluntary and Involuntary Exits, Continuous Improvement in Exit Management.

Text Books:

1. Analytics Talya Bauer, Berrin Erdogan, David E. Caughlin, Donald Martin Truxillo Human Resource Management: People, Data, and, SAGE Publication, 2nd Edition, ISBN-13: 9781071914649.
2. Gary Dessler and Biju Varkkey Human Resource Management (2020), Pearson Education, 16th Edition,

Reference Books:

1. Andreas von Grebmer, Global Employee Lifecycle Management, Book Baby, eBook ISBN: 9781623092207
2. Dieter Veldsman, Marna van der Merwe, Work for Humans: Designing the Employee Experience (2023), Springer, ISBN-13: 9783031835797

Web Links:

1. <https://nptel.ac.in/courses/110/104/110104105/>
2. <https://www.edx.org/course/people-management>

Relevant cases have to be discussed in each unit and in examination case study is compulsory from any unit.

CROSS CULTURE HRM

Course Code: 2505BB21

L	T	P	C
2		1	3

Course Outcomes:

At the end of the Course, Student will be able to:

- CO1:** Explain the concepts of International HRM by comparing with Domestic HRM.
- CO2:** Identify and manage various assignments in international context.
- CO3:** Demonstrate Cross Culture Communication and Negotiation
- CO4:** Analyze different Approaches of Compensation in Global Assignments
- CO5:** Apply the IHRD concepts through Global strategic advancements.

Mapping of Course Outcomes with Program Outcomes:

CO / PO	PO1	PO2	PO3	PO4	PO5	PO6	PO7	PO8	PO9	PO10	PO11
CO1	3	1	1	3	3	1	1	-	1	1	-
CO2	2	3	2	1	2	2	3	1	-	1	2
CO3	2	3	3	3	1	1	3	3	2	2	-
CO4	2	3	1	3	2	3	2	-	1	3	-
CO5	3	2	2	1	2	1	1	-	2	1	-

Mapping of Course Outcomes with Program Specific Outcomes:

CO/PSO	PSO1	PSO2	PSO3
CO1	3	1	1
CO2	3	2	3
CO3	3	3	3
CO4	3	3	1
CO5	3	3	1

UNIT-I

Introduction to Cross-Cultural HRM: Definition and functions of Cross-Cultural HRM, global workforce planning, international assignee management, differences between domestic and cross-cultural HRM, key international HRM issues: participation, work-life balance, ethics, employee safety, protectionism, and unionism.

UNIT-II

The Impact of Culture on HRM: Elements of culture, Hofstede's Cultural Dimensions, high and low-context cultures, gender biases, language challenges, employee behavior, cultural impact on decision-making, power, delegation, discrimination, diversity training, leadership in cross-cultural HRM.

UNIT-III

Expatriates and Inpatriates in the Global Workforce:

Mobile workforce factors, expatriates and inpatriates roles, cultural orientation approaches (ethnocentric, regiocentric, polycentric), expatriate performance evaluation, women expatriates, special needs managers.

UNIT-IV

Cross-Cultural HRM Practices:

Workforce planning, recruitment, selection, repatriation, diversity management, cross-cultural training, international compensation, performance management, employee relations, team management, CSR and ethics, HR as competitive advantage.

UNIT-V

Emerging Trends and Challenges in Cross-Cultural HRM:

Global HRM challenges, HR's strategic role in multinational organizations, gig economy, managing diverse teams, international business governance, cultural awareness, overcoming barriers in global HRM.

Text Books:

1. Jasmin Mahadevan, Cross-Cultural Management: A Contemporary Approach (May 23, 2023) SAGE Publications Ltd, ISBN-13: 978-1526459237.
2. Grosse, R.A, New Approach to Cross-Cultural People Management: People Are People Routledg, ISBN-13: 978-1032434780.

Reference Books:

1. Paul Iles & Crystal L. Zhang, International Human Resource Management: A Cross- Cultural and Comparative Approach, Kogan Page, ISBN-13: 978-1843983002.
2. Cross-Cultural Management: Essential Concepts David C. Thomas & Mark F. Peterson, SAGE Publications, 4th Edition ISBN-13: 978-1506340708

Web Links:

1. <https://www.shrm.org/>
2. <https://www.hofstede-insights.com/>

Relevant cases have to be discussed in each unit and in examination case study is compulsory from any unit.

TALENT ACQUISITION AND MANAGEMENT

Course Code: 2505BB40	L	T	P	C
	2		1	3

Course Outcomes:

At the end of the Course, Student will be able to:

- CO1:** Understand the concept, significance, and components of Talent Management, differentiating it from traditional recruitment processes.
- CO2:** Apply contemporary talent acquisition strategies, including employer branding and onboarding practices, aligned with organizational needs.
- CO3:** Analyze the use, benefits, and limitations of assessment centers and competency frameworks in identifying and developing talent.
- CO4:** Evaluate effective career management and succession planning practices to retain and nurture key talent.
- CO5:** Design mentoring programs, talent reward strategies, and incorporate ethical considerations in managing high-potential employees.

Mapping of Course Outcomes with Program Outcomes:

CO / PO	PO1	PO2	PO3	PO4	PO5	PO6	PO7	PO8	PO9	PO10	PO11
CO1	3	2	2	3	3	2	2	1	2	1	-
CO2	3	3	2	3	2	2	3	1	2	3	2
CO3	3	3	2	3	3	2	3	1	3	2	1
CO4	3	2	3	3	2	3	2	1	2	2	2
CO5	3	3	3	3	3	3	3	1	3	2	3

Mapping of Course Outcomes with Program Specific Outcomes:

CO / PSO	PSO1	PSO2	PSO3
CO1	3	2	1
CO2	3	3	2
CO3	3	3	3
CO4	3	3	2
CO5	3	3	2

UNIT-I

Introduction to Talent Management: Overview of Talent Management, Factors affecting Talent Management context globally, Need and Type of Talent, Four Components of Talent Management, Creating a Culture for Talent Management, Difference between Recruitment and Talent Acquisition, Definition and Role of Talent Acquisition in Talent Management.

UNIT-II

Talent Acquisition Strategies and Employer Branding: Contemporary Strategies in Acquiring Talent, Competing Value Proposition, Role of Employer Branding in Talent Acquisition, Onboarding New Hires and Socializing Challenges, Future Trends in Talent Acquisition.

UNIT-III

Assessment Centers and Competency Management: Concept, Definition, and Meaning of Assessment Centers, Use and Benefits of Assessment Centers, Outsourcing and Use of Technology in Assessment Centers, Training Assessors, Resources Required, Validity and Reliability of Assessment Centers, Disadvantages, When to Use and Not to Use Assessment Centers, Definition and Types of Competencies, Assessing and Developing Competencies, Competency Mapping at Individual and Task Level, Use of Competency Framework for Developing Talent.

UNIT-IV

Career Management and Succession Planning: Fundamentals of Career Planning, Trends and Best Practices in Career Planning, Models of Career Planning, Succession Planning Process and Issues, Challenges Pertaining to Succession Planning, Managing Performance and Potential of Key Talent, Managing the Potential of Key Talent.

UNIT-V

Mentoring, Rewarding Talent, and Ethics in Talent Management: Mentoring High Potential Talent, Process of Effective Mentoring, Gender Differences in Mentoring Process, Managing Reward and Benefits for Talent, Building Customized Talent Reward Strategy for Retaining Talent, War for Talent, Ethics of Managing Talent, Talent and Technology Trends.

Text Books:

1. Kevin Wheeler & Bas van de Haterd , Talent Acquisition Excellence: Using Digital Capabilities and Analytics to Improve Recruitment, Kogan Page, ISBN-13: 978- 1398614185
2. Dr. Darek L. Malone, The Leader's Guide to Talent Acquisition (January 3, 2024,) Independently Published, ISBN-13: 979-8873835072

Reference Books:

1. David G. Collings, Kamel Mellahi, & Wayne F. Cascio, The Oxford Handbook of Talent Management, Oxford University Press ISBN-13: 978-0198758273
2. Lance A. Berger & Dorothy R. Berger, The Talent Management Handbook, Third Edition Making Culture a Competitive Advantage by Acquiring, Identifying, Developing, and Promoting the Best People, McGraw Hill, ISBN-13: 978- 1259863554

Web Links:

1. https://onlinecourses.nptel.ac.in/noc23_hs47/preview
2. <https://www.coursera.org/learn/human-resources-analytics>

Relevant cases have to be discussed in each unit and in examination case study is compulsory from any unit.

HR ANALYTICS

Course Code: 2505BB27

L	T	P	C
2		1	3

Course Outcomes:

At the end of the Course, Student will be able to:

- CO1:** Explain the concept of analytics in an HR context and interpret key HR indicators to assess organizational effectiveness.
- CO2:** Identify and analyze key HR metrics, data sources, and ethical issues in HR measurement and evaluation.
- CO3:** Apply basic statistical tools such as measures of central tendency and regression analysis using HR datasets.
- CO4:** Demonstrate the ability to use HR analytics frameworks (LAMP, HCM 21) and processes to address real-world HR problems.
- CO5:** Develop and interpret HR scorecards and analytics dashboards to support evidence-based decision-making in HR

Mapping of Course Outcomes with Program Outcomes:

CO / PO	PO1	PO2	PO3	PO4	PO5	PO6	PO7	PO8	PO9	PO10	PO11
CO1	3	2	3	2	3	1	2	1	3	2	1
CO2	3	3	2	3	2	2	3	1	2	2	2
CO3	3	2	3	3	3	2	3	2	3	3	1
CO4	3	3	2	3	3	2	3	2	2	2	2
CO5	3	3	3	3	2	3	2	1	3	3	1

Mapping of Course Outcomes with Program Specific Outcomes:

CO/PSO	PSO1	PSO2	PSO3
CO1	3	2	1
CO2	3	3	2
CO3	3	2	3
CO4	3	3	2
CO5	3	3	1

UNIT-I

Introduction to HR Analytics: Concept of analytics, analytics in HR context, people and workforce analytics, importance of HR analytics, understanding HR indicators conceptually.

UNIT-II

HR Metrics and Data Management: Defining metrics, key metrics measured by HR analytics, demographics, data sources and requirements, types of data, difficulties in obtaining data, ethics of measurement and evaluation.

UNIT-III

Statistical Tools for HR Analytics: Statistical analysis for HR, measures of central tendency (mean, median, and mode), basics of regression analysis, graphs, tables, and spreadsheets.

UNIT-IV

HR Analytics Frameworks and Process: Frameworks for HR analytics, LAMP framework, HCM 21 framework, HR analytics process/cycle, levels of HR analytics.

UNIT-V

Application of HR Analytics in Decision-Making: Developing HR scorecard, developing HR analytics, analytics for decision-making, improved productivity and efficiency, case examples and applications.

Text Books:

1. Aboli Mande, Dr. Vaibhav Patil, Kalyani Sachin Patil, Pradip Kumar Sinha, Smita Kumbhar, HR Analytics: A Textbook (2025), Himalaya Publishing House ISBN-13: 978-93-5840-390-9.
2. Talya Bauer, Berrin Erdogan, David E. Caughlin, Donald M. Truxillo, Human Resource Management: People, Data, and Analytics (2025) SAGE Publications Publication, 2nd Edition. ISBN-13: 978-1071876855

Reference Books:

1. HR Analytics: Unlocking the Power of Data-Driven HR Management, Independently Published ISBN-13: 979-8313254845.
2. Transforming People Data into Strategic Insights: HR Analytics (2025), ISBN-13: 979-8314154670.

Web Links:

1. https://onlinecourses.nptel.ac.in/noc24_hs126/preview
2. <https://www.coursera.org/courses?query=hr+analytics>

Relevant cases have to be discussed in each unit and in examination case study is compulsory from any unit.

**COURSE-4: LOGISTICS AND SUPPLY CHAIN
REVERSE LOGISTICS**

Course Code: 2505BB35	L	T	P	C
	2		1	3

Course Outcomes:

At the end of the Course, Student will be able to:

- CO1:** Analyze the interdependencies between logistics and other business functions (e.g., marketing, production, finance).
- CO2:** Describe key logistical activities involved in forward and reverse logistics systems.
- CO3:** Identify the components involved in developing a supply chain strategy.
- CO4:** Examine the integration of logistics operations and their relationships within the supply chain.
- CO5:** Assess the role of supply chain management in e-business and B2B practices.

Mapping of Course Outcomes with Program Outcomes:

CO / PO	PO1	PO2	PO3	PO4	PO5	PO6	PO7	PO8	PO9	PO10	PO11
CO1	3	2	2	3	3	2	2	1	3	2	1
CO2	3	3	2	3	3	2	3	1	2	2	2
CO3	3	3	3	3	3	2	2	2	3	2	3
CO4	3	2	3	3	2	3	2	2	3	3	1
CO5	3	3	3	2	2	3	2	2	3	3	2

Mapping of Course Outcomes with Program Specific Outcomes:

CO/PSO	PSO1	PSO2	PSO3
CO1	3	2	1
CO2	3	3	2
CO3	3	3	3
CO4	3	2	3
CO5	3	3	2

UNIT-1

Reverse and Forward Logistics: Concepts of reverse and forward logistics, Applications in commercial and military sectors, Key metrics and performance, Best practices in military logistics, Managing system complexities.

UNIT-II

Principles of Reverse Logistics: Management principles for reverse logistics, Best practices in retail, apparel, electronics, and food industries, Reverse logistics in consumer goods.

UNIT- III

Returns Management: Customer returns handling, RMA processes, After-sales support best practices, Challenges in secondary markets.

UNIT - IV

Sustainable Reverse Logistics: Green reverse logistics practices, LEED-certified infrastructure, Global case studies on sustainable initiatives.

UNIT- V

Culture and Security in Reverse Logistics: Building a supportive organizational culture, Risk mitigation in reverse supply chains, Securing logistics networks.

Text Books:

1. Sanjivan Saini, Introduction to Reverse Logistics, Self-published via Barnes & Noble Press, ISBN: 9798223136293.
2. Robert Stanisławski & Andrzej Szymonik, Supply Chains in Reverse Logistics: The Process Approach for Sustainability and Environmental Protection, Taylor & Francis, ISBN: 9781032445298.

Reference Books:

1. Daoud Aït-Kadi, Marc Chouinard, Suzanne Marcotte, Diane Riopel, Sustainable Reverse Logistics Network: in Engineering and Management, (2024) ISTE Press / Wiley, ISBN: 9781848213104.
2. H.KDas, Er.RajnishVerma, Business Logistics /Supply Chain Management, S.Chand Publications, Pearson Education India; 5th edition ISBN- 6780649073809.

Web Links:

1. https://onlinecourses.nptel.ac.in/noc24_hs128/preview
2. https://ocw.mit.edu/courses/esd-s43-green-supply-chainmanagement/spring2014/resources/mitesd_s43s14_lecture4/

Relevant cases have to be discussed in each unit and in examination case study is compulsory from any unit

INTERNATIONAL LOGISTICS MANAGEMENT

Course Code: 2505BB28

L	T	P	C
2		1	3

Course Outcomes:

At the end of the Course, Student will be able to:

- CO1:** Explain the concept of logistics integration and barriers to integration.
- CO2:** Identify the international marketing and channels and modes of transport.
- CO3:** Develop the multimodal transport characteristics and tariff structures.
- CO4:** Assess the beneficial constraints of containerization and Chartering Containerization.
- CO5:** Prepare and manage customs documentation, including commercial invoices, bills of lading, and certificates of origin.

Mapping of Course Outcomes with Program Outcomes (PO):

CO / PO	PO1	PO2	PO3	PO4	PO5	PO6	PO7	PO8	PO9	PO10	PO11
CO1	3	2	2	2	2	1	2	2	1	1	1
CO2	3	2	2	3	2	1	2	2	2	2	1
CO3	3	3	3	3	2	2	2	2	2	2	2
CO4	3	3	3	3	2	2	2	2	3	2	2
CO5	3	3	3	3	3	2	2	2	3	2	2

Mapping of Course Outcomes with Program Specific Outcomes (PSO):

CO/PSO	PSO1	PSO2	PSO3
CO1	3	2	1
CO2	3	2	2
CO3	3	3	2
CO4	3	3	2
CO5	3	3	2

UNIT – I

Overview Logistics: Definition, Evolution, Concept, Components, Importance, Objectives; Logistic Sbsystem; The work of Logistics; Integrated Logistics; Barrier to Internal Integration.

UNIT – II

Marketing and Logistics: Customer-Focused Marketing, International Marketing (Definition, Trade Basis, Process, Importance), Marketing Channels (Clearing Agent Role, Transport Modes, Selection Issues, Cost Characteristics).

UNIT – III

Basics of Transportation: Functions & Principles, Multimodal Transport (Modal Characteristics & Comparisons, Legal Classifications), International Air Transport (Air Cargo Tariff Structure), Freight (Definition, Rates, Structure & Practice).

UNIT – IV

Containerization and Chartering Containerization: Containerization (Genesis, Concept, Classification, Benefits, Constraints), Inland Container Depot (ICD) (Roles, Functions, CFS,

Export Clearance, CONCOR, ICDs under CONCOR), Chartering (Types, Charter Party, Arbitration).

UNIT – V

Special Aspects of Export Logistics: Export Logistics (Picking, Packing, Vessel Booking [LCL/FCL], Customs, Documentation, Shipment, Delivery to Distribution Centers, Distributors, Retail Outlets). **Import Logistics** (Document Collection, Valuation, Bonded Warehousing, Customs Formalities).

Text Books:

1. John Mangan, Chandra Lalwani, Agustina Calatayud, Global Logistics and Supply Chain Management (April 2025) John Wiley & Sons Ltd, 5th Edition, ISBN: 978-1-394-26250-2.
2. Heather Skipworth, Remko Van Hoek, James Aitken, Alan Harrison, Logistics Management and Strategy: Competing through the Supply Chain (2025) Pearson Publication 7th Edition, ISBN: 978-1292479590.

Reference Books:

1. Strategic Logistics Management: Contemporary Principles and Practice, Kogan Page Ltd, 2025 ISBN: 978-1398618077
2. Dr. Vijesh Jain, International Logistics Management & INCOTERMS 2020 Rules, Independently published, ISBN: 9798879111699.

Web Links:

1. <https://www.vskills.in/certification/certified-international-logistics-management-professional-course-outline>
2. <https://archive.nptel.ac.in/courses/110/108/110108056/>

Relevant cases have to be discussed in each unit and in examination case study is compulsory from any unit.

QUALITY MANAGEMENT AND BUSINESS PROCESS IMPROVEMENT

Course Code: 2505BB33

L	T	P	C
2		1	3

Course Outcomes:

At the end of the Course, Student will be able to:

- CO1:** Describe the fundamental principles and evolution of Quality Management and its role in strategic performance.
- CO2:** Apply statistical tools and techniques for quality assurance in manufacturing and service industries.
- CO3:** Evaluate Total Quality Management and Six Sigma methodologies for process improvement.
- CO4:** Implement lean management practices and process optimization tools like Value Stream Mapping.
- CO5:** Analyze advanced quality practices and predict future trends through real-world case studies.

Mapping of Course Outcomes with Program Specific Outcomes (PSO):

CO / PO	PO1	PO2	PO3	PO4	PO5	PO6	PO7	PO8	PO9	PO10	PO11
CO1	3	2	1	2	2	2	2	2	1	2	2
CO2	3	3	3	3	2	3	2	2	2	2	2
CO3	3	3	3	3	3	3	2	2	2	2	2
CO4	3	3	3	3	2	3	3	2	2	2	2
CO5	3	2	2	2	2	3	3	3	2	2	2

Mapping of Course Outcomes with Program Specific Outcomes:

CO/PSO	PSO1	PSO2	PSO3
CO1	3	2	1
CO2	3	3	2
CO3	3	3	3
CO4	3	3	3
CO5	3	2	2

UNIT-I

Introduction to Quality Management: Definition, Evolution, and Principles of Quality Management, Role of Quality Management in Organizational Strategy and Performance.

UNIT-II

Statistical Tools for Quality Assurance: Statistical Quality Control (SQC), Tools and Techniques for Quality Assurance, Control Charts, Process Capability Analysis, Application in Manufacturing and Service Industries.

UNIT-III

Total Quality Management (TQM) and Six Sigma: TQM Principles and Frameworks (including Deming's 14 Points), Six Sigma Methodologies: DMAIC and DMADV, Tools like FMEA, SIPOC Diagrams for Process Improvement.

UNIT-IV

Process Optimization and Lean Management: Value Stream Mapping (VSM), Identifying Bottlenecks and Waste, Applying Lean Principles for Process Optimization, Continuous Improvement Strategies.

UNIT-V

Advanced Quality Practices and Future Trends: Emerging Quality Management Practices, Integration of TQM and Six Sigma in Modern Organizations, Industry Case Studies, Future Trends in Quality Management.

Text Books:

1. Patricia L. Shaw, EdD, RHIA, FAHIMA; Darcy Carter, DHSc, MHA, RHIA, Quality and Performance Improvement in Healthcare: Theory, Practice, and Management(2025), AHIMA Press, 8th Edition, ISBN: 978-1-58426-966-3
2. Nikhil Pal, Business Process Improvement in the Age of A (March 7, 2025), Independently published, ISBN: 979-8230093039

Reference Books:

1. David L. Goetsch & Stanley B. Davis, Quality Management for Organizational Excellence: Introduction to Total Quality (2021), Pearson. ISBN-13: 978-0135976974
2. Marc Helmold, Virtual and Innovative Quality Management Across the Value Chain (2024) Springer Cham ISBN: 978-3-031-30088-2

Web Links:

1. <https://www.coursera.org/learn/total-quality-management>
2. <https://www.sixsigmacouncil.org/>

Relevant cases have to be discussed in each unit and in examination case study is compulsory from any unit.

MANAGEMENT DECISION MODELS

Course Code: 2505BB30

L	T	P	C
2		1	3

Course Outcomes:

At the end of the Course, Student will be able to

- CO1:** Understand the role and importance of decision models in managerial problem-solving.
- CO2:** Apply decision-making techniques under certainty, risk, and uncertainty.
- CO3:** Formulate and solve linear programming problems in business contexts.
- CO4:** Analyze and solve transportation and assignment problems for resource optimization.
- CO5:** Demonstrate the use of simulation and decision support systems in functional areas of management.

At the end of the Course, Student will be able to

CO / PO	PO1	PO2	PO3	PO4	PO5	PO6	PO7	PO8	PO9	PO10	PO11
CO1	3	2	2	2	3	2	2	-	-	-	-
CO2	3	3	2	3	3	3	2	-	-	-	-
CO3	3	3	3	3	3	3	2	-	-	-	-
CO4	3	3	3	3	2	3	3	-	-	-	-
CO5	3	3	3	3	3	3	3	-	-	-	-

Mapping of Course Outcomes with Program Specific Outcomes:

CO/PSO	PSO1	PSO2	PSO3
CO1	-	1	-
CO2	-	1	-
CO3	-	1	-
CO4	-	1	-
CO5	-	1	-

UNIT I

Introduction to Managerial Decision Making and Modeling: Introduction to managerial decision making, Types of decisions, Decision-making process, Role of decision models, Quantitative techniques overview

UNIT – II

Decision Analysis under Certainty, Risk, and Uncertainty: Decision-making under certainty, risk, and uncertainty, Decision trees, Expected value, Minimax, Maximin, Utility theory basics

UNIT – III

Linear Programming and Its Applications: Linear programming, Problem formulation, Graphical method, Simplex concept, Applications in resource allocation

UNIT – IV

Transportation and Assignment Models: Transportation and assignment problems, NW Corner, Least Cost, Vogel’s method, MODI method, Hungarian method, Business applications

UNIT – V

Simulation and Decision Support Systems: Simulation basics, Monte Carlo simulation, Introduction to Decision Support Systems, Applications in business functions

Textbooks:

1. Render, B., Stair, R. M., & Hanna, M. E. (2018), Quantitative Analysis for Management, 13th Edition, Pearson Education, ISBN: 9780134543161
2. Vohra, N. D. (2017), Quantitative Techniques in Management, 5th Edition, McGraw Hill Education, ISBN: 9789352601870

Reference Books:

1. Anderson, D. R., Sweeney, D. J., & Williams, T. A. (2016), An Introduction to Management Science: Quantitative Approaches to Decision Making, Cengage Learning, ISBN: 9781305250901
2. Taha, H. A. (2011), Operations Research: An Introduction, 9th Edition, Pearson Education, ISBN: 9780132555937

Weblinks:

1. https://onlinecourses.nptel.ac.in/noc25_mg150/preview
2. https://onlinecourses.nptel.ac.in/noc24_mg90/preview

Relevant cases have to be discussed in each unit and in examination case study is compulsory from any unit.

DATA MINING FOR BUSINESS DECISIONS

Course Code: 2505BB22

L	T	P	C
2		1	3

Course Outcomes:

At the end of the Course, Student will be able to

- CO1:** Explain the fundamental concepts and principles of data mining and its applications.
- CO2:** Differentiate between Business Intelligence and Data Mining.
- CO3:** Identify and interpret clustering results using appropriate metrics and visualization techniques.
- CO4:** Analyze the principles and techniques of Web Mining, including web content mining, web structure mining, and web usage mining.
- CO5:** Determine the importance of data mining in transforming raw data into actionable knowledge.

Mapping of Course Outcomes with Program Outcomes:

CO / PO	PO1	PO2	PO3	PO4	PO5	PO6	PO7	PO8	PO9	PO10	PO11
CO1	3	2	2	2	1	1	3	1	1	2	2
CO2	3	3	2	2	1	1	3	1	1	2	1
CO3	3	3	3	3	2	2	3	1	1	2	2
CO4	3	3	2	2	2	2	3	1	1	2	1
CO5	3	2	3	3	2	2	3	2	2	2	2

Mapping of Course Outcomes with Program Specific Outcomes:

CO/PSO	PSO1	PSO2	PSO3
CO1	-	1	-
CO2	-	1	-
CO3	-	1	-
CO4	-	1	-
CO5	-	1	-

UNIT – I

Introduction to Data Mining: Introduction—Scope of Data Mining- What is Data Mining- How does Data Mining Works- Predictive Modelling- Data Mining and Data Warehousing- Architecture for Data Mining: Profitable Applications- Data Mining Tools.

UNIT – II

Business Intelligence: BI Overview, Tools, Infrastructure, Applications, BI vs. Data Warehouse, BI vs. Data Mining, Future of BI. Data Preprocessing: Overview, Cleaning, Integration & Transformation, Reduction, Discretization, Concept Hierarchy Generation.

UNIT – III

Data Mining Techniques an Overview: Data Mining Overview, DBMS vs. Data Mining, Techniques (Association Rules, Classification, Regression, Clustering, Neural Networks). Clustering: Basics, Cluster Analysis, Methods (K-Means, Hierarchical, Agglomerative, Divisive), Clustering Software, Cluster Evaluation.

UNIT – IV

Web Mining: Overview, Terminologies, Categories (Content Mining, Structure Mining, Usage Mining), Applications, Agent-Based & Database Approaches, Web Mining Software.

UNIT – V

Applications of Data mining: Business (Risk Management, Targeted Marketing, Customer Profiling), Medical (Diabetic Screening), Scientific, and Other Applications.

Text Books:

1. Andres Fortino, Data Mining and Predictive Analytics for Business Decisions: A Case Study Approach (February 18, 2023), Mercury Learning and Information ISBN-13: 978- 1683926757.
2. Han, Kamber & Pei., Data Mining: Concepts and Techniques, Third Edition ISBN-10:9780123814791, ISBN-13:978-9380931913

Reference Books:

1. Daniel T. Larose, Data Mining and Predictive Analytics (March 16, 2015), Wiley, 2nd Edition ISBN-13: 978-1118116197.
2. Ivo D. Dinov, Data Science and Predictive Analytics: Biomedical and Health Applications Using R (2023) Springer Publication, 2nd Edition ISBN-13: 978-3-031-17483-4

Web Links:

1. https://onlinecourses.nptel.ac.in/noc21_cs06/preview
2. <https://ggsestc.digimat.in/nptel/courses/video/110105089/L39.html>

Relevant cases have to be discussed in each unit and in examination case study is compulsory from any unit.

MANAGING SOFTWARE PROJECTS

	L	T	P	C
Course Code: 2505BB31	2		1	3

Course Outcomes:

At the end of the Course, Student will be able to:

- CO1:** Demonstrate leadership skills, including stakeholder management, communication, and conflict resolution, essential for project success.
- CO2:** Apply cost estimation, resource allocation, and budgeting techniques to manage project finances effectively.
- CO3:** Conduct qualitative and quantitative risk analysis to evaluate the likelihood and impact of risks on project objectives.
- CO4:** Navigate legal and regulatory frameworks governing procurement, contracting, and outsourcing activities.
- CO5:** Develop leadership qualities necessary for guiding and motivating project teams.

Mapping of Course Outcomes with Program Outcomes:

CO / PO	PO1	PO2	PO3	PO4	PO5	PO6	PO7	PO8	PO9	PO10	PO11
CO1	2	2	3	2	3	2	1	2	3	3	2
CO2	3	3	2	2	2	3	2	1	2	2	2
CO3	2	3	3	3	2	3	2	1	2	2	2
CO4	2	2	2	3	2	2	2	2	2	2	2
CO5	2	2	3	2	3	2	1	2	3	3	3

Mapping of Course Outcomes with Program Specific Outcomes:

CO/PSO	PSO1	PSO2	PSO3
CO1	-	1	-
CO2	-	1	-
CO3	-	1	-
CO4	-	1	-
CO5	-	1	-

UNIT – I

Introduction: Definition of Project & Project Management, Role of Project Manager, Project Management Profession, Project Life Cycle, Systems View, Organizational Context, Stakeholder Management, Project Phases, IT Project Context.

UNIT – II

Developing the Project Schedule: Project Management Software, Budgeting, Finalizing Schedule & Budget, Monitoring & Control, Communications Plan, Project Metrics, Performance Reporting, Information Distribution.

UNIT – III

Risk Management Planning: IT Project Risks, Risk Identification, Qualitative & Quantitative Analysis, Risk Response Planning, Monitoring & Control, Software for Risk Management.

UNIT – IV

Planning Purchase and Acquisitions: Planning contracting, requesting seller responses Selecting sellers, Administering the contract- Closing the contract - Using software to assist in project management – Outsourcing

UNIT – V

Project Leadership: Ethics in projects -Multicultural projects- Project implementation, administrative closure - Project evaluation

Text Books:

1. Guide to Software Project Management (April 29, 2025), Springer Publication ISBN-13: 978-3-031-80577-6 (Print) ISBN-13: 978-3-031-80578-3 (eBook)
2. Software Project Management: Methods and Techniques (2023), Routledge Publication: ISBN-13: 978-1032430577.

Reference Books:

1. Stellman & Greene SPD, Applied software project management. ISBN-10:0596009488, ISBN-13978-0596009489.
2. Richard Thayer, Edward Yourdon, Software Engineering Project Management, WILEY INDIA, ISBN-10:9812530959, ISBN-13:978-9812530950.

Web Links:

1. <http://www.digimat.in/nptel/courses/video/106105218/L01.html>
2. https://onlinecourses.nptel.ac.in/noc19_cs70/preview

Relevant cases have to be discussed in each unit and in examination case study is compulsory from any unit.

WEB DESIGNING

Course Code: 2505BB41

L	T	P	C
2		1	3

Course Outcomes:

At the end of the Course, Student will be able to:

- CO1:** Explain the history and evolution of the web and its underlying technologies.
- CO2:** Develop the HTTP message format and differentiate between persistent and non- persistent connections.
- CO3:** Construct web pages using HTML, including text, lists, links, images, tables, forms, frames, and meta tags.
- CO4:** Design and develop visually appealing web pages using CSS layout techniques.
- CO5:** Apply advanced JavaScript techniques, such as event handling and DOM manipulation.

Mapping of Course Outcomes with Program Outcomes:

CO / PO	PO1	PO2	PO3	PO4	PO5	PO6	PO7	PO8	PO9	PO10	PO11
CO1	2	2	2	3	1	2	1	2	3	3	2
CO2	3	3	2	2	2	3	2	1	2	2	2
CO3	3	2	3	3	1	2	2	2	3	3	3
CO4	3	2	3	2	2	2	3	2	3	3	2
CO5	3	3	3	3	2	3	3	3	3	2	2

Mapping of Course Outcomes with Program Specific Outcomes:

CO/PSO	PSO1	PSO2	PSO3
CO1	-	1	-
CO2	-	1	-
CO3	-	1	-
CO4	-	1	-
CO5	-	1	-

UNIT – I

Web Fundamentals: Introduction to the Web, History, Protocols, Website & Web App Development, Web Projects, Target Users, Web Team, Planning, Web Architecture, Challenges, Web Servers, Browsers, Internet Standards, TCP/IP, IP Addresses, MIME, Cyber Laws.

UNIT – II

Hyper Text Transfer Protocol (HTTP): HTTP Basics, Web Server & Clients, URL Structure, Message Format, Connections, Caching, Proxy. **Java Networking:** Classes & Interfaces, Internet Address Lookup, Client/Server, Socket Programming, Email Client. (Lab sessions included)

UNIT – III

Hyper Text Markup Language (HTML): Introduction, Structure, Text, Lists, Links, Images, Tables, Forms, Frames, Images, and Meta Tags. (lab sessions to be conducted)

UNIT – IV

Cascading Style Sheets (CSS): Introduction, Advantages, Color, Text, Boxes, Lists, Tables and Forms, Layout, Images, HTML5 Layout. (Lab Sessions to be conducted)

UNIT – V

JavaScript: Introduction, Variables, Literals, Operators, Control Structure, Conditional Statements, Arrays, Functions, Objects, JavaScript and HTML DOM, Advanced JavaScript and HTML Forms (Lab sessions to be conducted).

Text Books:

1. Paul McFedries, Web Design Playground (2024), Publisher: Manning Publications, Second Edition, ISBN: 978-1633438323.
2. HTML + CSS Programming, Guide for Beginners: Essential Web Design Skills (2024), Independently published Publication ISBN: 979-8344929781.

Reference Books:

1. Web Design with HTML & CSS: HTML & CSS Complete Beginner's Guide, Prem Kumar (Author), Notion Press, 31 October 2021. ISBN-10:1684878276, ISBN-13:978- 1684878277.
2. Web Designing and Development Training Guide, Jain/ Rai/ Geetha, BPB (2021). ISBN-10:8183335799, ISBN-13:978-8183335799.

Web Links:

1. <https://nptel.ac.in/courses/106106222>
2. <https://nptel.ac.in/courses/106106156>

Relevant cases have to be discussed in each unit and in examination case study is compulsory from any unit.

BUSINESS ANALYTICS

Course Code:2505BB17

L	T	P	C
2		1	3

Course Outcomes:

At the end of the Course, Student will be able to:

- CO1:** Trace the historical development of business analytics from its origins to the present day.
- CO2:** Demonstrate proficiency in using Excel for data manipulation, formula application, and data queries.
- CO3:** Formulate and solve linear optimization models using spreadsheet software.
- CO4:** Analyze market data using frameworks like PESTLE and Porter's Five Forces to gain strategic insights.
- CO5:** Implement strategies for effective Master Data Management to ensure data consistency and accuracy across organizations.

Mapping of Course Outcomes with Program Outcomes:

CO / PO	PO1	PO2	PO3	PO4	PO5	PO6	PO7	PO8	PO9	PO10	PO11
CO1	2	2	3	2	3	2	2	2	3	3	2
CO2	3	3	2	2	3	3	2	2	3	3	2
CO3	2	3	3	3	2	3	2	2	3	2	2
CO4	2	2	2	3	2	3	2	2	2	2	2
CO5	3	3	3	2	3	3	3	2	3	3	2

Mapping of Course Outcomes with Program Specific Outcomes:

CO/PSO	PSO1	PSO2	PSO3
CO1	1	2	1
CO2	1	2	1
CO3	1	2	1
CO4	1	3	1
CO5	2	3	1

UNIT – I

Introduction to Business Analytics: Evolution, scope, data types, models, problem-solving, analytics integration, competitive advantage, types of analytics (descriptive, predictive, prescriptive), dashboards, analytics process cycle.

UNIT – II

Analytics on Spreadsheets: Basic Excel, formulas, functions, data queries. Descriptive Analytics: Populations, samples, notations, measures of location, dispersion, association. Statistical Inference: Hypothesis testing, one/two-sample tests, ANOVA. Predictive Analytics: Simple/multiple regression, residual analysis, categorical variables.

UNIT – III

Machine Learning: Supervised/unsupervised learning, clustering, segmentation, association analysis, data reduction. Visual Analytics: Data visualization. Prescriptive Analytics: Linear optimization models, spreadsheet implementation, solving models.

UNIT – IV

Marketing Analytics: Models, metrics, data sources, market sizing, PESTLE, Porter’s Five Forces, basket analysis, text analytics, and spreadsheet modelling. Sales Analytics: E-commerce modes, sales, profitability, and support metrics.

UNIT – V

Introduction to Big Data: Master data management, types of data/patterns, technologies, applications, issues. Data Understanding: Data objects, attribute types, statistical descriptions, visualization, similarity /dissimilarity measures.

Text Books:

1. Vernon Richardson and Marcia Watson, Introduction to Business Analytics, McGraw Hill Publication, 1st Edition ISBN-13: 978-1265454340.
2. Sanjiv Jaggia, Alison Kelly, Kevin Lertwachara, and Leida Chen, Business Analytics (2025), McGraw Hill, 2nd Edition 2025 ISBN-13: 978-1264302802.

Reference Books:

1. Richard Huntsinger, Business Analytics: Methods and Cases for Data-Driven Decisions (2025), Cambridge University Press ISBN-13: 978-1316512159.
2. Brennan Davis, Business Analytics (2025) Stukent, Incorporat ISBN-13: 978-1734688818.

Web Links:

1. <https://archive.nptel.ac.in/courses/110/105/110105089/>
2. https://onlinecourses.nptel.ac.in/noc24_cs65/preview

Relevant cases have to be discussed in each unit and in examination case study is compulsory from any unit.

**ABILITY ENHANCEMENT COURSES
BUSINESS COMMUNICATION-1**

Course Code: 2505BB42

L	T	P	C
2	1		3

Course Outcomes:

At the end of the Course, Student will be able to:

- CO1:** Explain the fundamentals of organizational communication, including models, types, channels, barriers, and the 7Cs.
- CO2:** Demonstrate effective written communication through various business messages, emails, and formal letters.
- CO3:** Apply nonverbal communication skills by interpreting body language and vocal cues to enhance message effectiveness.
- CO4:** Apply interpersonal and presentation skills for effective communication in teams, virtual settings, and the gig economy.
- CO5:** Analyze effective digital communication skills and media literacy for professional and organizational contexts.

Mapping of Course Outcomes with Program Outcomes:

CO / PO	PO1	PO2	PO3	PO4	PO5	PO6	PO7	PO8	PO9	PO10	PO11
CO1	3	2	2	1	2	1	1	1	3	2	2
CO2	3	2	2	2	2	1	1	1	3	2	2
CO3	3	3	2	2	2	2	2	2	3	2	2
CO4	3	3	3	2	2	2	2	2	3	3	2
CO5	3	3	3	2	2	3	2	3	3	3	2

Mapping of Course Outcomes with Program Specific Outcomes:

CO / PSO	PSO1	PSO2	PSO3
CO1	3	2	2
CO2	3	2	2
CO3	3	3	2
CO4	3	3	2
CO5	3	3	2

UNIT – I

Introduction to Communication in Organizations: Introduction to Business Environment and Communication, Models of communication, Basics of Communication (types, channels and barriers), 7Cs of communication.

UNIT – II

Written Communication: Planning and executing different types of messages, emails, formal letters (Planning & Layout of Business Letter) and informal messages on e-platforms, negative messages: indirect & direct negative messages.

UNIT – III

Nonverbal Communication: Body Language: Understanding the significance of posture, gestures, and facial expressions, Tone of Voice: Recognizing the impact of vocal delivery on communication effectiveness.

UNIT – IV

Interpersonal Communication: Team communication, managing communication during online meeting, communication with virtual team, communication in gig economy; Presentation skills (Verbal and non-verbal); PowerPoint presentation skills.

UNIT – V

Digital Communication: Social media and individual, social media & organizations, Media Literacy; Strong Digital communication skills – email, instant messaging, video conferencing, e-meetings, digital etiquettes & responsibilities.

Text Books:

1. AICTE's Prescribed – Communication Skills in English, Khanna Book Publishing. 2. Lesikar,
2. R.V. & M.E. Flatley, Business Communication: Connecting in a Digital World, McGraw-Hill Education.

Reference Books:

1. Rao, M. T. (2023) Minor Hints: Lectures Delivered to H.H. the Maharaja Gaekwar, Sayaji Rao III. Gyan Publishing
2. Getting Ready for the Real World: HBR, 2020: The Science of Strong Business Writing.

Web Links:

1. https://onlinecourses.swayam2.ac.in/imb22_mg02/preview
2. https://ugcmoocs.inflibnet.ac.in/index.php/courses/view_pg/389

Relevant cases have to be discussed in each unit and in examination case study is compulsory from any unit.

BUSINESS COMMUNICATION –II

Course Code: 2505BB02

L	T	P	C
2	1		3

Course Outcomes (CO):

- CO1:** Apply business communication concepts in organizations.
- CO2:** Develop effective written communication (email, reports, and proposals).
- CO3:** Demonstrate oral communication skills (meetings, interviews, presentations).
- CO4:** Use negotiation and cross-cultural communication strategies.
- CO5:** Utilize digital communication tools effectively.

Mapping of Course Outcomes with Program Outcomes:

CO / PO	PO1	PO2	PO3	PO4	PO5	PO6	PO7	PO8	PO9	PO10	PO11
CO1	3	2	2	2	3	2	2	2	3	2	2
CO2	2	2	2	2	2	1	1	2	3	3	2
CO3	2	2	2	2	2	2	1	2	3	3	2
CO4	2	2	2	2	3	2	1	3	3	3	2
CO5	2	2	2	2	2	2	3	2	3	3	3

Mapping of Course Outcomes with Program Specific Outcomes:

CO / PSO	PSO1	PSO2	PSO3
CO1	2	2	2
CO2	2	2	2
CO3	2	2	2
CO4	2	2	2
CO5	2	2	2

UNIT- I

Written Communication in the Workplace: Intra-organizational communication; Office documents (Circulars, Memos, Notices); Positive & negative messages; IT tools (Emails, etiquette, online platforms); Corporate communication; Crisis communication; Culture as communication.

UNIT- II

Report and Proposal Writing: Business reports and RFP responses; Formal report structure; Organizing content; Digital age reporting; Industrial visit reports; Business proposals; Summarizing annual reports; Drafting meeting minutes.

UNIT- III

Oral Communication, Teamwork & Professionalism: Oral communication techniques; Media for communication (face-to-face, teleconferencing, podcasts); Oral reports, group discussions, team communication; Online/offline meeting etiquette; Conducting appraisals and interviews.

UNIT- IV

Negotiation & Cross-Cultural Communication: Negotiation skills; BATNA and communication; Body language; Globalization's impact; Cross-cultural communication frameworks (e.g., Hofstede); Workplace cultural skills and etiquette.

UNIT- V

Contemporary Digital Communication: Digital communication (social media, email, instant messaging, video conferencing); Digital collaboration and citizenship; Digital etiquette and responsibility; Personal and organizational websites; Podcasts.

Text Books:

1. Anjana Tiwari, Communication Skills in English (with Lab Manual) Khanna Book Publishing Co.
2. Lesikar & Flatley, Business Communication: Connecting in a Digital World McGraw-Hill Education.

References:

1. Stever Robbins, Culture as Communication
2. Men & Bowen, The Future of Internal Communication

Web links:

1. <https://online.hbs.edu/blog/post/how-to-communicate-organizational-change>
2. <https://hbsp.harvard.edu/product/BEP334-PDF-ENG>

Relevant cases have to be discussed in each unit and in examination case study is compulsory from any unit.

UNIT – II
Survival A/B/C/D

Listening	Conversation about a survival situation, Interview: The Tiger, Cooking for a friend, Talking about getting lost
Speaking	Telling a survival story, Giving advice; Asking questions, Giving compliments and responding, Discussing the natural environment
Reading	Article: Lost at sea, Leaflet: <i>How to survive...an animal attack</i> , Leaflet: <i>Be wise and survive</i>
Writing	Guidelines, organizing guidelines in a leaflet
Grammar	Narrative tenses, Future time clauses and conditionals
Vocabulary	Expressions with <i>get</i> , Animals and the environment
Pronunciation	Sound and Spelling: g, Intonation in question tags

UNIT – III
Talent A/B/C/D

Listening	Conversation: learning experiences, Radio Programme: The sports gene, Making wedding plans, Interviews about sport
Speaking	Talking about something you have put a lot of effort into, Discussing sport and ways to improve performance, planning a party, Talking about popular sports
Reading	Text about learning; <i>Learning to learn</i> , Article: <i>Born to be the best</i> ; Three articles about athletes, Article: <i>Fitness: Seattle snapshot</i>
Writing	Article describing data
Grammar	Multi-word verbs, Present perfect and present perfect continuous
Vocabulary	Ability and achievement, word connected with sport
Pronunciation	Word stress, sound and spelling consonant sounds

UNIT – IV
Life Lessons A/B/C/D

Listening	Interview: Psychology of money; Two monologues: Life-changing events, Two monologues; training for a job, Presenting photos, Three monologues; living in different places
Speaking	Talking about how your life has changes, Discuss experiences of training and rules, Describing photos: Expressing careful disagreement, Discussing living in a different country
Reading	Two texts about life-changing events that helped people become rich, Article: <i>Training for the emergency frontline</i> , Advert for being an international student ‘buddy’
Writing	Job application, Giving a positive impression
Grammar	<i>Used to</i> and <i>would</i>
Vocabulary	Cause and result, Talking about difficulty
Pronunciation	Sound and spelling: u

UNIT – V
Chance A/B/C/D

Listening	Monologue: What are your chances?, Conversation: Talking about work, Money problems, News reports: environmental problems
------------------	---

Speaking	Discussing possible future events, Role Play: job interview,
	Explaining and responding to an idea for a café, Giving opinions on environmental problems
Reading	Quiz: <i>Are you an optimist or a pessimist?</i> ; Article: <i>Why we think we're going to have a long and happy life</i> , Quiz: <i>The unknown continent</i> ; Article: <i>Cooking in Antarctica</i> , Essay about protecting the environment
Writing	For and against essay, Arguing for and against an idea
Grammar	Future probability, Future perfect and future continuous
Vocabulary	Adjectives describing attitude, The natural world
Pronunciation	Sound and spelling : <i>th</i> , Intonation groups

Textbook:

1. Cambridge Empower–SecondEditionB2Level-Adrian Doff, Craig Thaine, Herbert Puchta, Jeff Stranks, Peter Lewis–Jones.ISBN-10.9781107468726; ISBN- 13.978-1107468726

Suggested Software:

1. Cambridge Empower
2. SoftX(K-Van Solutions)

Reference Books:

1. MAshrafRizvi:EffectiveTechnicalCommunication.ISBN10-9352605780
2. Raymond Murphy: English Grammar in Use, Cambridge University, Press. Fifth Edition, ISBN-978-1-108-45765-1

Weblinks:

1. <https://www.cambridgeone.org/login>
2. <https://www.britishcouncil.in/english/online>
3. www.englishmedialab.com

ADVANCED COGNITIVE SKILLS FOR MANAGERS

Course Code:2505BB01

L T P C
1 1

Course Outcomes:

At the end of the course, student will be able to:

- CO1:** Recognize the basics of communication and summarize formal and informal expressions in all aspects.
- CO2:** Establish and maintain interpersonal relationships and transmit the message different language activities.
- CO3:** Use language effectively to prepare and demonstrate proficiency in facing various interviews.
- CO4:** Demonstrate and exhibit professionalism in participating in various public activities like debates, group discussions and presentation skills.
- CO5** Identify the basic elements of writing and apply the fundamentals to composing catering to different professional needs.

Mapping of Course Outcomes with Program Outcomes:

COs / POs	PO1	PO2	PO3	PO4	PO5	PO6	PO7	PO8	PO9	PO10	PO11
CO1	3	2	2	3	3	2	2	3	3	3	3
CO2	3	3	3	3	3	3	3	3	3	3	3
CO3	2	2	2	3	3	2	3	3	3	3	2
CO4	2	3	3	3	3	2	3	3	3	3	2
CO5	2	3	3	3	3	3	3	2	3	3	2

Mapping of Course Outcomes with Program Specific Outcomes:

CO / PSO	PSO1	PSO2	PSO3
CO1	2	2	3
CO2	2	3	3
CO3	2	2	3
CO4	2	2	3
CO5	2	2	3

UNIT – I

Around the globe A/B/C/D

Listening	Two monologues about sightseeing tours, Interview: disappearing languages, Asking for a favour, conversation: a trip to the Grand Canyon
Speaking	Comparing different tourist destinations, Agreeing and disagreeing, Asking for a favour, Discussing local tourist destinations.
Reading	Website about four tourist destinations; Website: Where to go?
Writing	Travel blog, Using descriptive language
Grammar	Infinitives and –ing forms
Vocabulary	Travel and tourism, Describing changes
Pronunciation	Consonant clusters, Consonant sounds

UNIT –II
City living A/B/C/D

Listening	Interview: ‘Smart’ cities: Two monologues talking about ‘smart’ cities, Two monologues: house renovations, Flat hunting, Interviews about a new shopping centre
Speaking	Discussing good and bad points about a city
Reading	Article: <i>Quick-slow down!</i> , Article: <i>Who puts the ‘real’ in reality</i> TV? Email: Complaining about an important issue.
Writing	Email of complaint, Using formal language
Grammar	<i>Too/enough; so/such</i> , Causative <i>have/get</i>
Vocabulary	Describing life in cities, Film and TV; Houses
Pronunciation	Sound and spelling: o, Stress in compound nouns

UNIT – III
Dilemmas A/B/C/D

Listening	Radio programme: person finance, Three monologues about honesty, Going to the bank, Conversation about a TV programme
Speaking	Giving opinions on financial matters, Discussing moral dilemmas, Talking about hopes and worries Discussing programmes about crime
Reading	Article: <i>Is it time to give up on cash?</i> , Newspaper article: <i>The honesty experiment</i> , Review: <i>Crime with a smile</i>
Writing	Review, Organising a review
Grammar	First and second conditionals, Third conditional; <i>should have+past participle</i>
Vocabulary	Money and finance, Crime
Pronunciation	Stressed and unstressed words; Sound and spelling: l, Word groups

UNIT –IV
Discoveries A/B/C/D

Listening	Conversation about inventions, Conversation about an email hoax, Finding the perfect flat, Four monologues about alternative medicine
Speaking	Talking about inventions, describing a hoax or a scam or a case of fraud, Giving and receiving surprises
Reading	Article: <i>Too good to be true?</i> , Article: <i>The rise and fall of Barry Minkow</i> , Essay: <i>The Value of alternative medicine</i>
Writing	Opinion essay, Presenting a series of arguments
Grammar	Relative clauses, Reported speech; Reporting verbs
Vocabulary	Health, Verbs describing thought and knowledge
Pronunciation	Sound and spelling : <i>ui</i> , Linking and intrusion

UNIT – V
Possibilities A/B/C/D

Listening	Interview about Dan Cooper, Two monologues: pursuing a dream, Celebrating good news, conversation about goals
Speaking	Telling stories about coincidences, Describing and comparing brave or amazing people, Telling an important piece of news, Talking

	about performing
Reading	Story: The man who disappeared; Blog: <i>The Wreck of the Titan</i> , Article: <i>Dream to help</i> , Story: Rosa's diary: <i>The ultimate goal</i>
Writing	Story, Making a story interesting
Grammar	Past modals of deduction, Wishes and regrets
Vocabulary	Adjectives with prefixes, Verbs of effort
Pronunciation	Word stress, Linking, Consonant clusters

Text Book:

1. Adrian Doff, Craig Thaine, Herbert Puchta, Jeff Stranks, Peter Lewis – Jones, Cambridge Empower–Second Edition, B2Level- ISBN-9789357260022.

Suggested Softwares:

1. Cambridge Empower
1. SoftX(K-Van Solutions)

Reference Books:

Bernard Widrow & Edward P. Katz, Cognitive Memory (2025), Springer,ISBN-13: 978- 3031809392

Weblinks:

1. <https://www.cambridgeone.org/login>
2. <https://www.coursera.org/>
3. <https://www.skillshare.com/>
4. <https://www.mindtools.com/cawh8bu/communication-tools>

EMPLOYABILITY SKILLS- V

Course Code:2505BB23

L T P C
1

Course Outcomes:

At the end of the Course, Student will be able to:

- CO1:** Apply principles of permutations, combinations, probability, and logarithms to solve quantitative aptitude problems.
- CO2:** Interpret and analyze data from charts, graphs, and statistical tables for decision-making and accuracy.
- CO3:** Evaluate logical reasoning statements involving arguments, assumptions, conclusions, and data sufficiency.
- CO4:** Solve puzzle and eligibility test problems using analytical and critical thinking skills.
- CO5:** Demonstrate effective interpersonal, communication, and time management skills for successful personal and professional interactions.

Mapping of Course Outcomes with Program Outcomes:

COs / POs	PO1	PO2	PO3	PO4	PO5	PO6	PO7	PO8	PO9	PO10	PO11
CO1	3	2	–	–	–	–	–	–	–	–	2
CO2	2	3	2	–	–	–	–	–	2	–	2
CO3	–	3	3	–	2	–	–	–	–	–	2
CO4	–	2	3	–	–	–	–	–	–	–	2
CO5	–	–	–	3	2	3	2	3	2	3	3

Mapping of Course Outcomes with Program Specific Outcomes:

CO \ PSO	PSO1	PSO2	PSO3
CO1	2	2	–
CO2	2	3	–
CO3	–	2	3
CO4	–	2	2
CO5	–	–	3

Aptitude:

Permutations and Combinations, Probability, Data Interpretation, Logarithms, Statistics

Reasoning:

Puzzle Tests, Eligibility Test, Data Sufficiency, Statements – Arguments, Statements – Assumptions, Statements - Course of Action, Statements - Conclusions

Verbal:

Interview skills, Grammar in use, Interpersonal Skills, Negotiation Skills, Social Skills, Problem-Solving Skills, Time Management Skills

TextBooks:

1. Dr.R.S.Aggarwal, Quantitative Aptitude, SCHAND.
2. Dr.R.S.Aggarwal, A Modern Approach to Verbal and Non-Verbal Reasoning
3. Dr.R.S.Aggarwal , QuickLearningObjectiveGeneralEnglish, SCHAND.

Reference Books:

1. Abhijit Guha, Quantitative Aptitude, McGraw-Hill Publications.
2. Jaikishan and Premkishan, Analytical Reasoning, Arihant Publications.
3. R.S.Dhillon, A New Approach to Objective English–DGP Publications.

Web Links:

1. www.indiabix.com
2. www.bankersadda.com

**MULTI-DISCIPLINARY COURSES
IT & AI SKILLS**

Course Code:2505BB53

L	T	P	C
1		2	3

Course Outcomes:

At the end of the Course, Student will be able to:

- CO1:** Explain the fundamentals of computers and their applications in business.
- CO2:** Build and format professional documents using MS Word.
- CO3:** Design and present impactful business presentations in MS PowerPoint.
- CO4:** Integrate and apply AI tools across MS Excel applications
- CO5** Analyze and visualize business data using MS Excel's functions.

Mapping of Course Outcomes with Program Outcomes:

CO / PO	PO1	PO2	PO3	PO4	PO5	PO6	PO7	PO8	PO9	PO10	PO11
CO1	3	1	1	–	1	–	–	1	3	–	2
CO2	2	1	1	2	1	–	–	–	3	–	2
CO3	2	1	1	3	1	1	–	–	3	2	2
CO4	2	2	2	1	1	–	1	–	3	1	3
CO5	2	3	3	1	1	–	1	–	3	1	3

Mapping of Course Outcomes with Program Specific Outcomes:

CO / PSO	PSO1	PSO2	PSO3
CO1	1	1	2
CO2	1	1	2
CO3	1	1	2
CO4	2	2	3
CO5	2	3	3

UNIT – I

Introduction to Computers: Definition, Components, Types; generations of computer; Computer Memory, Software and Hardware, Operating Systems. Window features. Introduction to Internet- benefit and limitation, IP address, Browser, E-mail.

UNIT – II

MS Word: Interface and Navigation: Document Formatting, Text Formatting, Paragraph Formatting, Advanced Features, Tables, Charts, and SmartArt, Mail Merge; AI Tools for MS Word.

UNIT – III

MS PowerPoint: Interface and Navigation; Slide Design and Layout, Adding and Formatting Text, Using Themes and Templates, Multimedia in Presentations, Presentation Tools, Slide Master and Custom Layouts, Slide Show Setup and Presentation Delivery; AI Tools for MS PowerPoint.

UNIT – IV

MS Excel: Interface and Navigation, Creating, Saving, and, Opening Workbooks, Basic Spreadsheet Operations, Entering and Formatting Data, Basic Formulas and Functions, Sorting and Filtering Data,

Data Visualization, Creating and Customizing Charts, Conditional Formatting; AI Tools for MS Excel.

UNIT – V

Advanced Excel: Lookup Functions: VLOOKUP, HLOOKUP, and XLOOKUP; Logical Functions: IF, AND, OR; Text Functions: CONCATENATE, LEFT, RIGHT; Date and Time **Functions:** DATE, TODAY, NETWORKDAYS.

Data Analysis and Visualization: PivotTables-Creating and analyzing data with PivotTables; Charts and Graphs: Designing and customizing basic charts; Conditional Formatting: Applying rules to highlight key data points.

Data Cleaning Techniques: Using Text to Columns and Remove Duplicates; Data Validation: Setting up rules to ensure data accuracy; Importing Data: Importing data from external sources like CSV and databases.

Text Books:

1. Dr.R.S.Aggarwal , Quantitative Aptitude, SCHAND.
2. Dr.R.S.Aggarwal, A Modern Approach to Verbal and Non-Verbal Reasoning
3. Dr.R.S.Aggarwal, QuickLearningObjectiveGeneralEnglish, SCHAND.

Reference Books:

1. AbhijitGuha, Quantitative Aptitude, McGraw-Hill Publications.
2. Jaikishan and Premkishan, Analytical Reasoning, Arihant Publications.
3. R.S.Dhillon, A New Approach to Objective English–DGPPublications.

Web Links:

1. www.indiabix.com
2. www.bankersadda.com

Relevant cases have to be discussed in each unit and in examination case study is compulsory from any unit

MEDIA LITERACY AND CRITICAL THINKING

	L	T	P	C
Course Code: 2505BB56	2			2

Course Outcomes:

At the end of the Course, Student will be able to:

CO1: Explain the notions of media, media literacy, main media types and formats

CO2: Identify the benefits and drawbacks of traditional and new media

CO3: Estimate the role and strategies of the media market players

CO4: Analyze the impact of different types of media content and narratives

CO5: Evaluate multimedia messages based on journalistic standards.

Mapping of Course Outcomes with Program Outcomes:

CO / PO	PO1	PO2	PO3	PO4	PO5	PO6	PO7	PO8	PO9	PO10	PO11
CO1	2	2	2	1	2	1	1	2	2	2	2
CO2	2	2	2	1	2	1	2	2	2	2	2
CO3	2	2	3	2	3	1	2	2	2	2	2
CO4	2	3	3	2	3	1	2	3	2	3	2
CO5	2	3	3	2	3	1	2	2	2	3	3

Mapping of Course Outcomes with Program Specific Outcomes:

CO / PSO	PSO1	PSO2	PSO3
CO1	2	1	2
CO2	2	1	2
CO3	2	1	2
CO4	2	2	3
CO5	2	2	3

UNIT – I

Introduction to Media: The notions of media and media literacy, History of media evolution, Forms and formats of media

UNIT – II

Traditional vs New media: Role and functions of Traditional and New Media, Social Media Platforms, Access to information

UNIT – III

Media Market Game: Rules and players- Media market players, Ownership and control of mass media market, Journalistic standards

UNIT – IV

Media content: Types and Narratives: The notion and types of media content, The notion and modes of narrative, Media narrative power

UNIT – V

Multimedia content: Types and Technologies: Multimedia terms and features, Multimedia formats and components, Multimedia messages

Text Books:

1. Chris Sperry & Cyndy Scheibe, Teaching Students to Decode the World: Media Literacy and Critical Thinking Across the Curriculum (February 2022), ASCD BN-13: 978-1416630937.
2. McQuail D. McQuail's Mass Communication Theory. 6th Edition. Sage Publications. ISBN-10:1849202923, ISBN-13: 978-1849202923

Reference Books:

1. Potter, W.J. Media Literacy, SAGE Publishing, 2021. 10th edition, 504 p. ISBN- 10:1071814451, ISBN-13:978-1071814451
2. Nick Pernisco, Media Literacy: An Essential Guide to Critical Thinking Skills for Our Complex Digital World (July 29, 2020), Independently published ISBN-13: 978- 1087896304.

Web Links:

1. <https://mediasmarts.ca/digital-media-literacy/general-information/digital-media-literacyfundamentals/media-literacy-fundamentals>
2. <http://www.hks.harvard.edu/fs/pnorris/Conference/Conference%20papers/Coronel%20Watchdog.pdf>

**VALUE ADDED COURSES
ENVIRONMENTAL SCIENCE AND SUSTAINABILITY**

	L	T	P	C
Course Code: 2505BB48	2			2

Course Outcomes:

At the end of the Course, Student will be able to:

- CO1:** Explain the functions of environment, ecosystems and biodiversity and their conservation.
- CO2:** Identify the causes, effects of environmental pollution and natural disasters and contribute to the preventive measures in the society.
- CO3:** Apply the understanding of renewable and non-renewable resources and contribute to the sustainable measures to preserve them for future generations.
- CO4:** Describe various environmental acts
- CO5:** Recognize the different goals of sustainable development and apply them for suitable technological advancement and societal development.

Mapping of Course Outcomes with Program Outcomes:

CO / PO	PO1	PO2	PO3	PO4	PO5	PO6	PO7	PO8	PO9	PO10	PO11
CO1	1	1	1	–	2	–	–	3	–	–	1
CO2	1	2	2	–	3	1	1	3	–	–	1
CO3	1	2	2	–	2	1	3	3	2	–	1
CO4	–	1	1	–	3	1	–	2	–	–	–
CO5	1	2	2	1	3	2	2	3	2	1	2

Mapping of Course Outcomes with Program Specific Outcomes:

CO / PSO	PSO1	PSO2	PSO3
CO1	1	-	2
CO2	1	2	2
CO3	2	2	3
CO4	1	1	2
CO5	2	2	3

UNIT – I

Environment and Biodiversity: Definition, scope and importance of environment – need for public awareness. Eco-system and Energy flow– ecological succession. Types of biodiversity.

UNIT – II

Environmental Pollution: Causes, Effects and Preventive measures of Water, Soil, Air and Noise Pollutions. Solid, Hazardous and E-Waste management, Environmental protection acts.

UNIT – III

Renewable Sources of Energy: Energy management and conservation, New Energy Sources: Need of new sources. Different types new energy sources.

UNIT – IV

Environmental Acts: The Water (Prevention and Control of Pollution) Act, 1974-The Air (Prevention and

Control of Pollution) Act, 1981-The Environment (Protection) Act, 1986 Objectives.

UNIT – V

Sustainability Practices: Zero waste and R concept, Circular economy, ISO 14000 Series, Material Life cycle assessment, Environmental Impact Assessment.

Text Books:

1. Benny Joseph, _Environmental Science and Engineering ‘, Tata McGraw-Hill, New Delhi.ISBN-10:9387432351, ISBN-13: 978-9387432352.
2. Anubha Kaushik and C. P. Kaushik’s —Perspectives in Environmental Studies|, 6th Edition, New Age International Publishers.ISBN-10:9789386418630, ISBN-13:978- 9386418630.

Reference Books:

1. R.K. Trivedi, _Handbook of Environmental Laws, Rules, Guidelines, Compliances and Standards, Vol. I and II, Enviro Media. ISBN-10: 8178002213, ISBN-13:978- 8178002217.
2. Cunningham, W.P. Cooper, T.H. Gorhani, _Environmental Encyclopedia, Jaico Publ., House, Mumbai. ISBN-10:8172247869, ISBN-13: 978-8172247867.

Web Links:

1. https://onlinecourses.nptel.ac.in/noc23_hs155/preview
2. https://onlinecourses.swayam2.ac.in/nou20_ag12/preview

INDIAN CONSTITUTION

Course Code: 2505BB51

L	T	P	C
2			2

Course Outcomes:

At the end of the Course, Student will be able to:

- CO1:** Identify and explore the basic features and modalities about Indian constitution
- CO2:** Explain the fundamental and administrative structure of various branches of Government
- CO3:** Differentiate and relate the functioning of Indian parliamentary system at the centre and state level.
- CO4:** Examine different aspects of Indian Legal System and its related bodies.
- CO5:** Understand and abide the federal distribution and powers of the Indian constitution

Mapping of Course Outcomes with Program Outcomes:

CO / PO	PO1	PO2	PO3	PO4	PO5	PO6	PO7	PO8	PO9	PO10	PO11
CO1	2	2	1	2	1	2	2	3	1	2	2
CO2	2	2	2	2	1	1	2	2	2	2	2
CO3	2	2	2	2	1	1	2	2	2	2	2
CO4	2	2	3	2	2	2	2	3	2	2	2
CO5	2	2	3	2	2	2	2	3	2	2	2

Mapping of Course Outcomes with Program Specific Outcomes:

CO / PSO	PSO1	PSO2	PSO3
CO1	1	-	2
CO2	1	2	2
CO3	2	2	3
CO4	1	1	2
CO5	2	2	3

UNIT – I

Constitution: Meaning & Constitutionalism, Historical perspective -: 1909 Act, 1919 Act & 1935 Act, Salient features & nature of the Constitution,

UNIT – II

Fundamental Rights: Introduction & its scheme, Right to Equality (Art.14), Right to Fundamental Freedoms (Art. 19), Right to Life (Art. 21), Directive Principles of State Policy: importance and implementation, Fundamental Duties and its legal status.

UNIT – III

Union Government: Structures of the Union Government and Functions – President – Vice President – Prime Minister – Cabinet – Parliament – Supreme Court of India – Judicial Review.

UNIT – IV

State Government: Structure and Functions – Governor – Chief Minister – Cabinet – State Legislature – Judicial System in States – High Courts and other Subordinate Courts.

UNIT – V

Federal structure: Federal structure & distribution of legislative and financial powers between the Union and the States.

Text Books:

1. D.D. Basu, Introduction to the Constitution of India, Lexis Nexis, New Delhi, ISBN 10-9388548868.
2. Subhash C. Kashyap, Indian Constitution, National Book Trust, New Delhi. ISBN- 10: 9352704428, ISBN-13:978-8123707341.

Reference Books:

1. Dr. G. B. Reddy & Mohd. Suhaib, Constitution of India and Professional Ethics, Dream tech Press, ISBN-10:818986601X, ISBN-13:978-8189866013.
2. B.Z. Fadia & Kuldeep Fadia, Indian Government & Politics, Lexis Nexis, New Delhi, ISBN-10: 9384885622, ISBN-13: 978-9384885625.

Web Links:

1. <https://archive.nptel.ac.in/courses/129/106/129106003/>
2. https://onlinecourses.nptel.ac.in/noc24_1w05/preview

INTERNATIONAL BUSIENSS

Course Code: 2505BB10	L	T	P	C
	2		1	3

Course Outcomes:

At the end of the Course, Student will be able to:

- CO1:** Understand the fundamental concepts of international business, stages of internationalization, and global business environments.
- CO2:** Analyze classical and modern international trade theories and evaluate the impact of tariff and non-tariff barriers on global trade.
- CO3:** Interpret the role of Foreign Direct Investment (FDI), international institutions, and investment models in shaping global economic flows.
- CO4:** Evaluate regional economic integrations, trade blocs, and multilateral trade agreements, and their implications for business decisions.
- CO5:** Assess emerging trends in international business, including digital trade, CSR, ESG practices, and the impact of geopolitical and environmental shifts.

Mapping of Course Outcomes with Program Outcomes:

CO / PO	PO1	PO2	PO3	PO4	PO5	PO6	PO7	PO8	PO9	PO10	PO11
CO1	3	2	2	3	3	2	2	2	2	2	3
CO2	3	3	3	2	2	2	2	2	2	2	3
CO3	3	3	3	2	3	2	2	2	2	2	3
CO4	3	3	3	3	3	3	2	2	2	3	3
CO5	3	3	3	3	3	3	3	3	3	3	3

Mapping of Course Outcomes with Program Specific Outcomes:

CO / PSO	PSO1	PSO2	PSO3
CO1	3	2	2
CO2	3	3	2
CO3	3	3	3
CO4	3	3	3
CO5	3	3	3

UNIT I

Fundamentals of International Business: Introduction to international business, Nature and scope, Stages of internationalization, EPRG framework (Ethnocentric, Polycentric, Regiocentric, Geocentric), Globalization and its impact, International business environment – economic, political, cultural, legal.

UNIT II

International Trade Theories and Barriers: Mercantilist theory, Absolute advantage, Comparative advantage, Factor proportions theory, Neo-factor proportions theory, Country similarity theory, Intra-industry trade, Tariff barriers, Non-tariff barriers, Role of WTO in trade liberalization.

UNIT III

Foreign Direct Investment and Global Institutions: Definition of FDI, Greenfield and Brownfield FDI, Theories of FDI, Benefits and costs of FDI, Trends in global FDI, CAGE model (Cultural, Administrative, Geographic, Economic distance), Role of international institutions – IMF, World Bank, UNCTAD.

UNIT IV

Economic Integration and Trade Agreements: Economic indicators and business decisions, Regional economic integration – Free trade area, Customs union, Common market, Economic union, Regional trade blocs – EU, NAFTA, ASEAN, SAARC, Multilateral trade negotiations, Instruments of trade regulation, Emerging markets and developing economies.

UNIT V

Contemporary Trends and Challenges in International Business: International entrepreneurship, Born global firms, Corporate social responsibility (CSR), ESG investing and reporting, Corporate responses to climate change and social justice, Brexit and international business laws, Rise of digital platforms, E-commerce trends, Re-shoring and near-shoring, Impact of COVID-19 on international business.

Text Books:

1. S. Tamer Cavusgil, Gary Knight, John R. Riesenberger, International Business: The New Realities (Date: July 2, 2024), Pearson Publication, 6th Edition, ISBN-13: 978-0138183769
2. Charles W.L. Hill , International Business: Competing in the Global Marketplace (2025, McGraw Hill, 14th Edition, ISBN-13: 978-1260387544.

Reference Books:

1. John J. Wild and Kenneth L. Wild, International Business: The Challenges of Globalization (2022), Pearson Education, 9th Edition,.
2. Jeffrey F. Beatty, Susan S. Samuelson, Patricia Sanchez Abril , International Business Law and Its Environment(2025), Publisher: Cengage, 11th Edition, ISBN-13: 978-0357717868.

Web Links:

1. https://books.google.com/books/about/International_Business_2e.html?id=c3GGYIMWWMQC
2. <https://www.amazon.in/International-Business-2e-K-Aswathappa/dp/007059953X>

Relevant cases have to be discussed in each unit and in examination case study is compulsory from any unit.

PUBLIC HEALTH AND MANAGEMENT

Course Code: 2505BB14

L	T	P	C
2			2

Course Outcomes:

At the end of the Course, Student will be able to:

- CO1:** Explain the key concepts, evolution, and global frameworks of public health.
- CO2:** Identify the role of social determinants and health equity in public health outcomes
- CO3:** Describe the structure, issues, and major programmes of the Indian health system.
- CO4:** Apply basic planning and management tools in public health settings.
- CO5:** Analyze public health programmes using monitoring, evaluation, and health system frameworks.

Mapping of Course Outcomes with Program Outcomes:

CO / PO	PO1	PO2	PO3	PO4	PO5	PO6	PO7	PO8	PO9	PO10	PO11
CO1	3	2	2	1	3	1	2	1	1	1	2
CO2	2	2	1	3	3	2	3	1	1	2	1
CO3	3	3	2	1	2	3	2	1	1	2	2
CO4	3	3	3	2	2	3	1	2	2	1	2
CO5	3	3	3	2	2	3	1	2	2	1	3

Mapping of Course Outcomes with Program Specific Outcomes:

CO / PSO	PSO1	PSO2	PSO3
CO1	2	2	1
CO2	2	2	2
CO3	3	2	2
CO4	3	3	3
CO5	3	3	3

UNIT I

Foundations of Public Health: Concept of public health and its role in society, evolution of public health, understanding health and disease, and global health frameworks.

UNIT II

Health Determinants and Equity: Health equity, social determinants of health, access to healthcare and social justice, and the role of public health in reducing disparities.

UNIT III

Health Systems in India: History of public health in India, organization of health systems in India, key issues in India's health system, and major health schemes and programmes including the National Health Mission, Integrated Child Development Services (ICDS), Janani Suraksha Yojana, Ayushman Bharat Scheme, and POSHAN Abhiyan.

UNIT IV

Health Planning and Management: Concepts of planning from macro to micro level, tools for health planning, district-level health management, and strategies for effective implementation.

UNIT V

Monitoring, Evaluation, and Frameworks: Introduction to monitoring and evaluation (M&E), purpose and process of M&E in public health, health system frameworks, and application of frameworks in programme assessment.

Text Books:

1. Goldstein RL, Goldstein K, Dwelle TL Introduction to Public Health: Promises and Practices, Springer Publishing Company.
2. Sen A, “Health in Development”, Bulletin of the World Health Organization, Vol. 77(8).

Reference Books:

1. R N Batta (, “Public health management in India: Concerns and options”, Journal of Public Administration and Policy Research, Vol. 7(3).
2. National Health Policy 2017, Ministry of Health and Family Welfare, Govt. of India.

Web Links:

1. <https://nptel.ac.in/courses/121106007>
2. <https://nptel.ac.in/courses/127106227>

Relevant cases have to be discussed in each unit, and in examination, case study is compulsory from any unit.

UNIT – IV

Blockchain Technology: Blockchain fundamentals, Decentralized ledger, Cryptography, Smart contracts, Financial services, Security, Privacy, Regulatory challenges.

UNIT – V

AR/VR: AR/VR concepts, Applications in marketing and training, Immersive technologies, Challenges and opportunities, Technological advancements, Integration in business processes.

Text Books:

1. Mohamed Anis Bach Tobji, Rim Jallouli, Yamen Koubaa, Anton Nijholt, Digital Economy. Emerging Technologies and Business Innovation, ISBN 10:9783319977485, ISBN-13:978-3319977485.
2. Timothy Jung, M. Claudia tom Dieck, Augmented Reality and Virtual Reality: Empowering Human, Place and Business, (2019). ISBN-10: 3319877038, ISBN-13: 978-3319877037

Reference Books:

1. Paul Mealy, Virtual & Augmented Reality for Dummies. ISBN-13:9978-1119481348.
2. Dr. Sanjay Sharma, Emerging Technology (2022), ISBN: 9789392549151.

Web Links:

1. <https://nptel.ac.in/courses/106105166>
2. https://onlinecourses.nptel.ac.in/noc22_cs53/preview

Relevant cases have to be discussed in each unit and in examination case study is compulsory from any unit.

MANAGEMENT INFORMATION SYSTEMS

Course Code:2505BB13

L	T	P	C
2		1	3

Course Outcomes:

At the end of the Course, Student will be able to:

- CO1:** Explain the information needs of an organization and a business function
- CO2:** Identify the effectiveness of decision-making process and MIS design
- CO3:** Utilize DSS techniques for making effective decisions
- CO4:** Design parameters for information systems process and application
- CO5** Apply DBMS to attain the goals of the organization

Mapping of Course Outcomes with Program Outcomes:

CO / PO	PO1	PO2	PO3	PO4	PO5	PO6	PO7	PO8	PO9	PO10	PO11
CO1	3	2	2	3	3	3	3	2	3	3	3
CO2	3	2	3	3	3	2	3	3	2	3	3
CO3	3	3	3	3	3	3	3	2	3	3	3
CO4	3	3	2	3	2	3	3	3	3	3	2
CO5	3	3	3	3	3	3	2	3	3	3	3

Mapping of Course Outcomes with Program Specific Outcomes:

CO / PSO	PSO1	PSO2	PSO3
CO1	3	2	2
CO2	3	3	2
CO3	3	3	3
CO4	3	3	3
CO5	3	3	3

UNIT I

Introduction to Management Information Systems (MIS): Overview of MIS, types of MIS, dimensions and components of information systems (IS), benefits of MIS, IT infrastructure, evolution of IT infrastructure, and new approaches for system building in the digital era.

UNIT II

Database Management Systems (DBMS): Objectives of database approach, characteristics of DBMS, data processing systems, components of DBMS packages, database administration, and the Entity-Relationship (ER) model.

UNIT III

Information System Applications: MIS applications, Decision Support Systems (DSS), Group Decision Support Systems (GDSS), DSS applications in e-enterprise, Knowledge Management Systems (KMS), Expert Systems (KBES), Enterprise Model Systems, E-business, E-commerce, E-communication, and Business Process Reengineering.

UNIT IV

Project Management Basics: Objectives of project management, fundamentals of project management information systems (PMIS) with agile methodologies, introduction to SCRUM, roles and meetings, user stories, project risk management, and controlling risk factors.

UNIT V

Ethical, Social, and Political Issues in Information Systems: Ethical, social, and political considerations in managing information systems, with a focus on the implications of these issues in the information era.

Text Books:

1. Bernd Schenk, Advanced Management Information Systems: Models, Concepts and Cases (2025), Springer Cham Publication, ISBN-13: 978-3031879036
2. Kenneth C. Laudon & Jane P. Laudon, Management Information Systems: Managing the Digital Firm (2021) Pearson Publication, 17th Edition, ISBN-13: 978-0136971542

Reference Books:

1. Prasad L.M., Prasad Usha, Management Information Systems (2023), Sultan Chand & Sons, ISBN- 81-8054-814-7
2. Goyal, D.P.: Management Information System, MACMILLAN India Limited, New Delhi. ISBN-10 : 14 03930996, ISBN-13: 978-1403930996

Web Links:

1. https://onlinecourses.nptel.ac.in/noc20_mg60/preview
2. <https://archive.nptel.ac.in/courses/122/105/122105022/>

Relevant cases have to be discussed in each unit and in examination case study is compulsory from any

ENTERPRISE SYSTEM AND PLATFORMS

Course Code: 2505BB06

L	T	P	C
2		1	3

Course Outcomes:

At the end of the Course, Student will be able to:

- CO1:** Understand enterprise systems, platforms, and business process integration.
- CO2:** Analyze ERP, SCM, CRM, and EAM functions in business operations.
- CO3:** Evaluate enterprise platforms like SAP, Oracle, and Microsoft Dynamics.
- CO4:** Explore business intelligence, big data analytics, and security in enterprise systems.
- CO5:** Examine emerging trends like AI, blockchain, and IoT in enterprise systems.

Mapping of Course Outcomes with Program Outcomes:

CO / PO	PO1	PO2	PO3	PO4	PO5	PO6	PO7	PO8	PO9	PO10	PO11
CO1	3	2	1	2	1	2	3	1	2	2	1
CO2	3	3	2	2	1	3	3	2	3	2	1
CO3	3	3	2	2	2	3	3	1	2	2	1
CO4	2	3	1	2	2	3	3	2	2	3	2
CO5	2	2	2	2	2	3	3	2	2	3	2

Mapping of Course Outcomes with Program Specific Outcomes:

CO / PSO	PSO1	PSO2	PSO3
CO1	2	2	3
CO2	2	2	3
CO3	2	2	3
CO4	1	2	3
CO5	2	2	3

UNIT I

Introduction to ERP: Definition, evolution, and significance of ERP; Key drivers, components, and core modules (Finance, HR, Supply Chain); Benefits, challenges, and solutions in ERP implementation.

UNIT II

ERP System Design and Architecture: ERP system design, SDLC for ERPs, Customization vs. Standardization; ERP architecture including Three-Tier Architecture; System integration and compatibility.

UNIT III

ERP Vendors and Solutions: Overview of major ERP vendors (SAP, Oracle, Microsoft, etc.); Comparative study of ERP solutions; Selection criteria based on business needs and scale.

UNIT IV

ERP Implementation and Management: Implementation strategies, project planning, data migration, integration; Risk management, training, post-implementation support, and continuous improvement.

UNIT V

Advanced ERP and Future Trends: Advanced ERP features, BI & analytics, cloud-based ERP; Emerging technologies like IoT, AI & ML in ERP; ERP's role in business strategy and digital transformation.

Text Books:

1. Paige Baltzan & Amy Phillip, Business Driven Information Systems (2025) McGraw Hill Publication, 9th Edition, ISBN-13: 978-1264638727
2. Johan Magnusson, Enterprise System Platforms (2025) Student litteratur AB Publication ISBN- 13: 978-9144096704

Reference Books:

1. Veena Bansal, Enterprise Resource Planning: A Managerial Perspective (May 2024), Pearson India ISBN-13: 9781306254311
2. Luvai F. Motiwalla & Jeffrey Thompson, Enterprise Systems for Management, Pearson Publication, 2nd Edition, ISBN-13: 9780132145763

Web Links:

1. NPTEL Course on Enterprise Systems
2. SAP Official Learning Hub

Relevant cases have to be discussed in each unit and in examination case study is compulsory from any unit.

DESIGN THINKING AND INNOVATION

Course Code: 2505BB46

L	T	P	C
2			3

Course Outcomes:

At the end of the Course, Student will be able to:

- CO1:** Explain the core concepts and historical evolution of Design Thinking.
- CO1:** Apply empathy research methods to gather user insights and create problem statements and journey maps.
- CO1:** Analyze ideation techniques and develop prototypes using various tools.
- CO1:** Evaluate user feedback and implement iterative design improvements.
- CO1:** Examine the principles and processes of innovation and differentiate between types of innovation.

Mapping of Course Outcomes with Program Outcomes:

CO / PO	PO1	PO2	PO3	PO4	PO5	PO6	PO7	PO8	PO9	PO10	PO11
CO1	3	2	2	2	2	2	2	1	1	2	1
CO2	2	3	2	2	2	2	3	2	3	2	1
CO3	2	3	2	3	2	3	3	2	3	2	1
CO4	2	2	2	2	2	3	2	1	2	2	1
CO5	3	2	3	2	2	2	3	2	2	2	1

Mapping of Course Outcomes with Program Specific Outcomes:

CO / PSO	PSO1	PSO2	PSO3
CO1	2	2	2
CO2	2	2	3
CO3	2	2	3
CO4	2	2	2
CO5	2	2	3

UNIT I

Introduction to Design Thinking: Covers innovation, creative thinking, problem-solving approaches, and the Design Thinking process—Empathize, Define, Ideate, Prototype, and Implement—using examples like Apple, Netflix, and Airbnb.

UNIT II

Empathy and Problem Understanding: Focuses on developing empathy using design tools, observing users, understanding uniqueness, and identifying complex "wicked problems" around us.

UNIT III

Ideation and Defining Solutions: Introduces brainstorming, systems thinking, and mapping customer experiences to generate creative solutions to defined problems.

UNIT IV

Prototyping and Implementation: Covers rapid prototyping, testing ideas, and planning implementation, with emphasis on converting ideas into practical solutions.

UNIT V

Feedback and Redesign: Focuses on gathering user feedback, improving design based on experience, and presenting final innovative solutions.

Text Books:

1. Gavin Ambrose, Paul Harris, Basics Design - 8: Design Thinking, illustrated, reprint, AVA Publishing, ISBN-10:2940411174, ISBN-13: 978-2940411177.
2. Christian Müller-Roterberg, Handbook of Design Thinking, Kindle Direct Publishing, ISBN: 978-1790435371.

Reference Books:

1. C S G Krishnamacharyulu & Lalitha R, Innovation Management, Himalaya Publishing House. ISBN-10:9350979209, ISBN-13: 978-9350979204.
2. Vinnie Jauhari, Sudanshu Bhushan, Innovation Management, Oxford Higher Education. ISBN-10: 0198080980, ISBN-13: 978-0198080985.

Web Links:

1. https://onlinecourses.nptel.ac.in/noc22_mg32/preview
2. https://onlinecourses.swayam2.ac.in/imb23_mg65/preview

Relevant cases have to be discussed in each unit and in examination case study is compulsory from any unit.

CORPORATE GOVERNANCE

	L	T	P	C
Code:2505BB20	2			2

Course Outcomes:

At the end of the Course, Student will be able to:

- CO1:** Explain the concept, importance, and principles of corporate governance.
- CO2:** Analyze the role of board structures and committees in corporate governance.
- CO3:** Evaluate corporate governance practices in India and globally.
- CO4:** Understand the role of ethics, CSR, and sustainability in corporate governance.
- CO5:** Examine corporate frauds and governance failures with case studies.

Mapping of Course Outcomes with Program Outcomes:

CO / PO	PO1	PO2	PO3	PO4	PO5	PO6	PO7	PO8	PO9	PO10	PO11
CO1	3	2	2	1	2	3	2	1	2	1	2
CO2	3	3	2	1	2	3	2	2	1	1	2
CO3	3	3	2	2	3	3	2	2	1	1	2
CO4	2	2	2	1	3	3	2	3	1	2	2
CO5	2	3	2	2	3	3	2	2	2	1	2

Mapping of Course Outcomes with Program Specific Outcomes:

CO / PSO	PSO1	PSO2	PSO3
CO1	2	1	2
CO2	3	2	2
CO3	3	3	2
CO4	2	2	2
CO5	3	2	3

UNIT - I

Introduction to Corporate Governance: Meaning, significance, and principles of Corporate Governance, relationship between management and corporate governance, theories of Corporate Governance: Agency Theory, Stewardship Theory, Stakeholder Theory, one-tier and two-tier board structures.

UNIT -II

Role of Stakeholders in Corporate Governance: Board composition: Executive, Non-Executive, and Independent Directors, role and responsibilities of the Board and its committees, insider trading and shareholder activism, class action suits, whistleblowing mechanism, and CSR's role in governance.

UNIT -III

Global Corporate Failures and International Codes: Case studies: Maxwell (UK), Enron (USA), Sir Adrian Cadbury Committee Report (1992), Sarbanes-Oxley (SOX) Act 2002, OECD Principles of Corporate Governance.

UNIT -IV

Corporate Governance in India: Kumar Mangalam Birla Committee (1999), NR Narayana Murthy Committee (2005), and Uday Kotak Committee (2017), regulatory framework: Companies Act, 2013, and SEBI's LODR (2015), governance failures in India: Satyam Computer Services, Kingfisher Airlines, PNB Heist, ICICI Bank.

UNIT -V

Analysis of Corporate Failures and Governance Problems: Common governance issues in corporate failures in India and abroad, lessons from corporate governance failures, analysis of preventive measures and solutions.

Text Books:

1. Bob Tricker, Corporate Governance: Principles, Policies, and Practices (2025), Oxford University Press, 5th Edition, ISBN-13: 978-0192885456
2. Jason Harris, Principles of Contemporary Corporate Governance, (2024), Cambridge University Press, ISBN-13: 978-1009287388

Reference Books:

1. Salvatore Esposito De Falco Corporate Governance: Theories, Actors, and Control Systems in the Age of New Capitalism, (2024), Palgrave Macmillan Publication ISBN-13: 978-3-031- 74091-6
2. Shital Jhunjhunwala, Corporate Governance: Creating Value for Stakeholder (2024), Palgrave Macmillan Singapore, ISBN-13: 978-981-99-2771-5

Web Links:

1. <https://nptel.ac.in/courses/110/106/110106145/>
2. https://www.youtube.com/watch?v=7TjdC_zUG8k

Relevant cases have to be discussed in each unit, and in examination, case study is compulsory from any unit.

**MANDATORY COURSES
EMPLOYABILITY SKILLS-1**

Course Code:2505AC01

L T P C
2

Course Outcomes:

At the end of the Course, Student will be able to:

- CO1:** Apply fundamental arithmetic concepts such as number systems, LCM & HCF, ratio & proportion, and averages to solve quantitative problems efficiently.
- CO2:** Analyze number and letter series to identify logical patterns and predict subsequent elements.
- CO3:** Select the option by evaluating relationships in analogy-based problems and detecting inconsistencies in logical sequences
- CO4:** Demonstrate effective verbal communication skills by using appropriate parts of speech and tone in various interpersonal and professional contexts.

Mapping of Course Outcomes with Program Outcomes:

CO / PO	PO1	PO2	PO3	PO4	PO5	PO6	PO7	PO8	PO9	PO10	PO11
CO1	3	2	–	–	–	–	–	–	–	–	2
CO2	–	3	2	–	–	–	–	–	–	–	2
CO3	–	3	3	–	1	–	–	–	–	–	2
CO4	–	–	–	3	–	2	–	2	–	3	2

Mapping of Course Outcomes with Program Specific Outcomes:

CO \ PSO	PSO1	PSO2	PSO3
CO1	2	2	–
CO2	2	3	–
CO3	–	2	3
CO4	–	–	3

Aptitude:

Number System, LCM & HCF, Ratio and Proportion, Averages

Reasoning:

Number Series, Letter Series, Number Analogy, Letter Analogy, Odd Man Out, Logical Sequence of Words.

Verbal:

Introduction to soft skills, how to improve communication? Parts of Speech, Mind your language towards better English, Vocabulary Expansion

Text Books:

1. Dr. R. S. Aggarwal, Quantitative Aptitude for Competitive Examinations, S. Chand Publishing, ISBN: 978-9352534029
2. Dr. R. S. Aggarwal, A Modern Approach to Verbal and Non-Verbal Reasoning, S. Chand Publishing, ISBN: 978-9352832163

Reference Books:

1. Dr. R. S. Aggarwal, Vikas Aggarwal, Quick Learning Objective General English, S. Chand Publishing, ISBN: 978-9352837564
2. Abhijit Guha, Quantitative Aptitude for Competitive Examinations, McGraw Hill Education, ISBN: 978-9353160180
3. M. K. Pandey, Analytical Reasoning, Arihant Publications, ISBN: 978-9350947982

Web Links:

1. www.indiabix.com
2. www.bankersadda.com

EMPLOYABILITY SKILLS-1I

L T P C
2

Course Code: 2505AC02

Course Outcomes:

At the end of the Course, Student will be able to:

- CO1:** Apply percentage, profit & loss, and partnership concepts to solve real-world quantitative problems.
- CO2:** Analyze age-related problems to develop logical problem-solving strategies.
- CO3:** Evaluate logical reasoning questions including ranking, directions, and alphabet tests for accurate decision-making.
- CO4:** Solve pattern-based problems in coding and decoding to enhance analytical skills.
- CO5:** Demonstrate effective written communication using correct grammar and structured presentation techniques

Mapping of Course Outcomes with Program Outcomes:

CO / PO	PO1	PO2	PO3	PO4	PO5	PO6	PO7	PO8	PO9	PO10	PO11
CO1	3	2	–	–	–	–	–	–	–	–	2
CO2	–	3	2	–	–	–	–	–	–	–	2
CO3	–	3	3	–	1	–	–	–	–	–	2
CO4	–	2	3	–	–	–	–	–	–	–	2
CO5	–	–	–	3	–	2	–	2	–	3	2

Mapping of Course Outcomes with Program Specific Outcomes:

CO \ PSO	PSO1	PSO2	PSO3
CO1	2	2	–
CO2	2	3	–
CO3	–	2	3
CO4	–	2	2
CO5	–	–	3

Aptitude:

Problems on Ages, Partnership, Percentages, Profit and Loss

Reasoning:

Coding and Decoding, Ranking Test, Alphabet Test, Direction Test

Verbal:

Written communication skill practice, Grammatical use, Concept of 4 step method for presentation, Present Tense

Text Books:

1. Dr. R. S. Aggarwal, Quantitative Aptitude for Competitive Examinations, S. Chand Publishing, ISBN: 978-9352534029
2. Dr. R. S. Aggarwal, A Modern Approach to Verbal and Non-Verbal Reasoning, Publication: S. Chand Publishing, ISBN: 978-9352832163

Reference Books:

1. Dr. R. S. Aggarwal, Vikas Aggarwal, Quick Learning Objective General English, S. Chand Publishing, ISBN: 978-9352837564
2. Abhijit Guha, Quantitative Aptitude for Competitive Examinations, McGraw Hill Education, ISBN: 978-9353160180
3. M. K. Pandey, Analytical Reasoning, Arihant Publications, ISBN: 978-9350947982

Web Links:

1. www.indiabix.com
2. www.bankersadda.com

EMPLOYABILITY SKILLS-III

Course Code: 2505AC03

L T P C
2

Course Outcomes:

At the end of the Course, Student will be able to:

- CO1:** Solve financial and quantitative aptitude problems using concepts of simple and compound interest.
- CO2:** Apply logical time-work frameworks to solve real-time problems related to work efficiency and pipe systems.
- CO3:** Analyze and interpret problems related to blood relations, clocks, calendars, and coded inequalities.
- CO4:** Evaluate spatial and logical reasoning through cubes, dice, and symbolic interpretation problems.
- CO5** Demonstrate effective communication using correct grammar, and participate actively in discussions and comprehension activities.

Mapping of Course Outcomes with Program Outcomes:

CO / PO	PO1	PO2	PO3	PO4	PO5	PO6	PO7	PO8	PO9	PO10	PO11
CO1	3	2	–	–	–	–	–	–	–	–	2
CO2	2	3	2	–	–	–	–	–	–	–	2
CO3	–	3	3	–	1	–	–	–	–	–	2
CO4	–	2	3	–	–	–	–	–	–	–	2
CO5	–	–	–	3	–	2	–	2	–	3	2

Mapping of Course Outcomes with Program Specific Outcomes:

CO \ PSO	PSO1	PSO2	PSO3
CO1	2	2	–
CO2	2	3	–
CO3	–	2	3
CO4	–	2	2
CO5	–	–	3

Aptitude:

Simple Interest, Compound Interest, Time and Work, Pipes and Cisterns

Reasoning:

Blood Relations, Calendar, Clocks, Cubes and Dice, Coded Inequalities

Verbal:

Grammar in use, Group discussion, Reading Comprehension, Past Tense, Future Tense

Text Books:

1. Dr. R. S. Aggarwal, Quantitative Aptitude for Competitive Examinations , S. Chand Publishing, ISBN: 978-935253402
2. Dr. R. S. Aggarwal, A Modern Approach to Verbal and Non-Verbal Reasoning, S. Chand Publishing, ISBN: 978-9352832163

Reference Books:

1. Dr. R. S. Aggarwal, Vikas Aggarwal, Quick Learning Objective General English ,S. Chand Publishing, ISBN: 978-9352837564
2. Abhijit Guha, Quantitative Aptitude for Competitive Examinations, McGraw Hill Education, ISBN: 978-9353160180
3. M. K. Pandey, Analytical Reasoning Arihant Publications, ISBN: 978-9350947982

Web Links:

1. www.indiabix.com
2. www.bankersadda.com

EMPLAOYABILITY SKILLS-IV

L T P C
2

Course Code: 2505AC04

Course Outcomes:

At the end of the Course, Student will be able to:

- CO1:** Apply concepts of time, speed, distance, trains, boats and streams to solve motion-related aptitude problems.
- CO2:** Solve mensuration problems involving surface area and volume in real-world contexts.
- CO3:** Analyze logical reasoning questions involving Venn diagrams and syllogisms to make valid conclusions.
- CO4:** Interpret seating arrangements and solve non-verbal reasoning questions involving patterns and spatial reasoning.

Mapping of Course Outcomes with Program Outcomes:

CO / PO	PO1	PO2	PO3	PO4	PO5	PO6	PO7	PO8	PO9	PO10	PO11
CO1	3	2	–	–	–	–	–	–	–	–	2
CO2	3	2	–	–	–	–	–	–	–	–	2
CO3	–	3	3	–	1	–	–	–	–	–	2
CO4	–	2	3	–	–	–	–	–	–	–	2

Mapping of Course Outcomes with Program Specific Outcomes:

CO \ PSO	PSO1	PSO2	PSO3
CO1	2	2	–
CO2	2	2	–
CO3	–	2	3
CO4	–	2	2

Aptitude:

Time, Speed and Distance, Problems on Trains, Boats and Streams, Mensuration-I, Mensuration - II

Reasoning

Venn Diagrams, Syllogisms, Non - Verbal Reasoning, Seating Arrangement

Verbal:

Grammatical use, Self-introduction, Letters, E-Mail & Report writing, Error correction, Effective Communication

Text Books:

1. Dr. R. S. Aggarwal, Quantitative Aptitude, S Chand Publications.
2. Dr. R. S. Aggarwal, A Modern Approach to Verbal and Non-Verbal Reasoning , Quick Learning
3. Dr. R. S. Aggarwal, S Chand, Objective General English

Reference Books:

1. Abhijit Guha, Quantitative Aptitude ,Mc Graw Hill Publications.
2. Jaikishan and Premkishan, Analytical Reasoning , Arihant Publications.
3. R. S. Dhillon, A New Approach to Objective English , DGP Publications.

Web Links:

1. www.indiabix.com
2. www.bankersadda.com