

PROGRAM CURRICULUM

(Applicable for the batches admitted from A.Y 2025-26)

TWO YEAR P.G PROGRAM

MASTER OF BUSINESS ADMINISTRATION



A D I T Y A
U N I V E R S I T Y

Aditya Nagar, ADB Road, Surampalem, Andhra Pradesh

VISION & MISSION OF THE UNIVERSITY

VISION

To be a globally recognized University through excellence in Education, Innovation, and Sustainable Growth

MISSION

Deliver collaborative education to prepare students for global challenges through

1. Transformative learning.
2. Vibrant research ecosystem.
3. Sustainable and inclusive community

VISION & MISSION OF THE SCHOOL OF BUSINESS

VISION

To be a world-class business school advancing academic excellence, innovation, and global talent to develop responsible leaders shaping an inclusive and sustainable future

MISSION

M1: Deliver transformative business education that blends academic rigor with real-world relevance and ethical grounding.

M2: Nurture globally competent, entrepreneurial leaders through innovation, research, and interdisciplinary learning.

M3: Champion sustainability, social impact, and inclusive growth through collaborative industry and community engagement

PROGRAM OUTCOMES (POs)

After successful completion of the program, the graduates will be able to

- PO1: Application of Management Principles:** Demonstrate the ability to apply foundational and advanced management concepts to address real-world business challenges with practical and effective solutions.
- PO2: Analytical and Critical Reasoning:** Develop strong analytical and critical thinking skills to support data-driven decision-making in dynamic business environments.
- PO3: Value-Centered Leadership:** Cultivate leadership capabilities rooted in integrity, ethics, and a commitment to creating long-term value for organizations and society.
- PO4: Global and Ethical Awareness:** Exhibit a deep understanding of global business dynamics, including economic, legal, and ethical considerations, and communicate these effectively in diverse business contexts.
- PO5: Collaborative Leadership:** Demonstrate the ability to lead and contribute meaningfully in team settings, effectively driving organizational objectives through shared vision and cooperation.
- PO6: Innovation and Research Orientation:** Identify emerging business opportunities, generate research insights, and implement innovative ideas across varied functional and sectorial domains.
- PO7: Tech-Driven Business Adaptability:** Stay abreast of disruptive and emerging technologies, applying them strategically to modernize and enhance business processes and models.
- PO8: Community Engagement and Impact:** Foster meaningful engagement with underserved communities through socially responsible outreach, aiming to create inclusive and transformative business solutions.

PROGRAM SPECIFIC OUTCOMES (PSOs)

After successful completion of the program,

- PSO1: Strategic and Functional Integration:** Graduates will be able to integrate knowledge across core business functions (marketing, finance, HR, operations, analytics) to solve complex business challenges and design effective organizational strategies.
- PSO2: Innovation, Entrepreneurship, and Business Transformation:** Graduates will demonstrate the ability to identify market opportunities, develop innovative solutions, and lead entrepreneurial ventures or transformational initiatives within existing organizations.
- PSO3: Data-Driven Decision-Making and Digital Agility:** Graduates will proficiently apply analytical tools, digital technologies, and data-driven insights to enhance organizational decision-making and drive competitive advantage in a technology-enabled global environment

PROGRAM EDUCATIONAL OBJECTIVES (PEOs)

After successful completion, this program will support

- PEO 1: Strengthen Business Foundations:** To equip students with a comprehensive understanding of core business functions and processes. This includes fostering an integrated perspective of value-creating activities within an organization and how they interact to drive overall business success.
- PEO 2: Nurture Strategic Thinking:** To develop students' ability to think critically and strategically by analyzing multifaceted business challenges, exploring feasible solutions, and making sound decisions that align with long-term organizational goals.
- PEO 3: Build Leadership Excellence:** To cultivate essential leadership competencies such as effective communication, collaboration, team management, motivation, and ethical judgment—empowering students to take on leadership roles and guide organizations with confidence and integrity.
- PEO 4: Develop a Global Outlook:** To prepare students to navigate the complexities of the international business landscape by enhancing their awareness of diverse cultures, global market dynamics, and emerging business trends, thereby fostering a truly global mindset.
- PEO 5: Instill Ethical and Social Responsibility:** To instill a deep understanding of ethical standards and social responsibility in business, enabling graduates to make decisions that reflect accountability, stakeholder sensitivity, and a commitment to sustainable practices.

Master of Business Administration
Program Curriculum-2025

Credit Division:

S. No	Category of Courses	Credits
1	Program Core Courses (PCC)	53
2	Major Elective Courses (MEC)	24
3	Minor Elective Courses (MIEC)	09
4	Ability Enhancement Course (AEC)	02
5	Summer Internship (SI)	4
6	Capstone Project (CPROJ)	4
7	Mandatory courses (MC)	0
Total Credits		96

Program Core Courses (PCC)

Course Code	Course Title	L	T	P	C	CIE	SEE	Total	Pre-requisite
2508MS56	Management and Organization Behavior	2		1	3	50	50	100	
2508MS01	Accounting for Managers	3	1		4	50	50	100	-
2508MS58	Managerial Economics	2		1	3	50	50	100	-
2508MS16	Business Statistics and Analysis for Decision-Making	3	1		4	50	50	100	-
2508MS54	Legal and Business Environment	2		1	3	50	50	100	-
2508MS64	Marketing Management	2		1	3	50	50	100	-
2508MS31	Digital Productivity in AI Tools	2		1	3	50	50	100	-
2508MS24	Corporate Finance	2		1	3	50	50	100	-
2508MS42	Human Resource Management	2		1	3	50	50	100	MOB
2508MS15	Business Research Methodology	3	1		4	50	50	100	BSADM
2508MS69	Operations Management	2		1	3	50	50	100	-
2508MS12	Business communication and Soft skills	2			2	50	50	100	-
2508MS78	Startup & New Venture	2		1	3	50	50	100	-
2508MS13	Business Ethics and Corporate Governance	2		1	3	50	50	100	LBE
2508MS57	Management Information Systems	2		1	3	50	50	100	DPIAIT
2508MS80	Strategic Management	2		1	3	50	50	100	-
2508MS17	Business Taxation	2	1		3	50	50	100	AFM
	Total				53				

Major Elective Courses (MEC)

Major Electives	Finance	Marketing	HR	Business Analytics	Logistics and Supply Chain	Digital Transformation and Innovation	Digital Marketing
MEC-I	Investment Analysis and Port Folio Management	Sales and Retail Management	Performance Management	Data Analysis with Python	Logistics Management	Data Mining for Business Decisions	Digital Startup and New Venture Management
MEC-II	Banking and Financial Institutions	Consumer Behavior & Customer Relationship Management	International Human Resource Management	Marketing Analytics	Store Keeping and Warehousing Management	Managing Software Projects	Consumer Analytics
MEC-III	Introduction to FinTech	Marketing Analytics	HR Analytics	Financial Analytics	Transportation and Infrastructure Management for SCM	Web Designing	E- Mail Marketing
MEC-IV	Mergers, Acquisitions and Corporate Restructuring	Strategic Marketing Management	Organization Change and Development	HR Analytics	Purchasing and Material Management	Business Analytics	Mobile Marketing
MEC-V	Financial Risk Management and Financial Derivatives	Digital & Social Media Marketing	Contemporary Practices in HR	Time series forecasting and Data visualization	Reverse Logistics	Managing Digital Innovation and Transformation	Search Engine Optimization
MEC-VI	International Finance	Service Marketing	Industrial Relations	Big Data Analytics	Supply Chain Risk Management	Big Data Analytics	Social Media Marketing
MEC-VII	Behavioral Finance	Marketing Research	Labor Welfare and Legislation	Web Analytics	Enterprise Resource Planning	Cyber Laws & Security	Content Marketing
MEC-VIII	Financial Analytics	Brand Management	Compensation and Reward Management	Data Mining & Machine Learning	International Logistics Management	Information Systems Audit	Affiliate Marketing and Google AdSense

Finance (FIN)									
Course Code	Course Title	L	T	P	C	CIE	SEE	Total	Pre- requisite
2508MS51	Investment Analysis and Port Folio Management	2	1		3	50	50	100	-
2508MS05	Banking and Financial Institutions	2		1	3	50	50	100	
2508MS50	Introduction to FinTech	2		1	3	50	50	100	
2508MS66	Mergers, Acquisitions and Corporate Restructuring	2		1	3	50	50	100	
2508MS38	Financial Risk Management and Financial Derivatives	2		1	3	50	50	100	
2508MS46	International Finance	2		1	3	50	50	100	
2508MS06	Behavioral Finance	2		1	3	50	50	100	
2508MS36	Financial Analytics	2		1	3	50	50	100	

Marketing (MKTG)									
Course Code	Course Title	L	T	P	C	CIE	SEE	Total	Pre- requisite
2508MS74	Sales and Retail Management	2		1	3	50	50	100	-
2508MS21	Consumer Behavior & Customer Relationship Management	2		1	3	50	50	100	
2508MS62	Marketing Analytics	2		1	3	50	50	100	
2508MS81	Strategic Marketing Management	2		1	3	50	50	100	
2508MS29	Digital & Social Media Marketing	2		1	3	50	50	100	
2508MS76	Service Marketing	2		1	3	50	50	100	
2508MS65	Marketing Research	2		1	3	50	50	100	
2508MS10	Brand Management	2		1	3	50	50	100	

Human Resource (HR)									
Course Code	Course Title	L	T	P	C	CIE	SEE	Total	Pre-requisite
2508MS71	Performance Management	2		1	3	50	50	100	-
2508MS47	International Human Resource Management	2		1	3	50	50	100	
2508MS40	HR Analytics	2		1	3	50	50	100	
2508MS70	Organization Change and Development	2		1	3	50	50	100	
2508MS22	Contemporary Practices in HR	2		1	3	50	50	100	
2508MS43	Industrial Relations	2		1	3	50	50	100	
2508MS52	Labor Welfare and Legislation	2		1	3	50	50	100	
2508MS19	Compensation and Reward Management	2		1	3	50	50	100	

Business Analytics (BA)									
Course Code	Course Title	L	T	P	C	CIE	SEE	Total	Pre-requisite
2508MS26	Data Analysis with Python	2		1	3	50	50	100	-
2508MS63	Marketing Analytics	2		1	3	50	50	100	
2508MS37	Financial Analytics	2		1	3	50	50	100	
2508MS41	HR Analytics	2		1	3	50	50	100	
2508MS87	Time series forecasting and Data visualization	2		1	3	50	50	100	
2508MS07	Big Data Analytics	2		1	3	50	50	100	
2508MS90	Web Analytics	2		1	3	50	50	100	
2508MS28	Data Mining & Machine Learning	2		1	3	50	50	100	

Logistics and Supply Chain (LSC)									
Course Code	Course Title	L	T	P	C	CIE	SEE	Total	Pre-requisite
2508MS55	Logistics Management	2		1	3	50	50	100	-
2508MS79	Store Keeping and Warehousing Management	2		1	3	50	50	100	
2508MS89	Transportation and Infrastructure Management for SCM	2		1	3	50	50	100	
2508MS72	Purchasing and Material Management	2		1	3	50	50	100	
2508MS73	Reverse Logistics	2		1	3	50	50	100	
2508MS85	Supply Chain Risk Management	2		1	3	50	50	100	
2508MS34	Enterprise Resource Planning	2		1	3	50	50	100	
2508MS48	International Logistics Management	2		1	3	50	50	100	

Digital Transformation and Innovation (DTAI)									
Course Code	Course Title	L	T	P	C	CIE	SEE	Total	Pre-requisite
2508MS27	Data Mining for Business Decisions	2		1	3	50	50	100	-
2508MS61	Managing Software Projects	2		1	3	50	50	100	
2508MS91	Web Designing	2		1	3	50	50	100	
2508MS11	Business Analytics	2		1	3	50	50	100	
2508MS60	Managing Digital Innovation and Transformation	2		1	3	50	50	100	
2508MS08	Big Data Analytics	2		1	3	50	50	100	
2508MS25	Cyber Laws & Security	2		1	3	50	50	100	
2508MS44	Information Systems Audit	2		1	3	50	50	100	

Digital Marketing (DM)									
Course Code	Course Title	L	T	P	C	CIE	SEE	Total	Pre-requisite
2508MS32	Digital Startup and New Venture Management	2		1	3	50	50	100	-
2508MS20	Consumer Analytics	2		1	3	50	50	100	
2508MS33	E- Mail Marketing	2		1	3	50	50	100	
2508MS67	Mobile Marketing	2		1	3	50	50	100	
2508MS75	Search Engine Optimization	2		1	3	50	50	100	
2508MS77	Social Media Marketing	2		1	3	50	50	100	
2508MS23	Content Marketing	2		1	3	50	50	100	
2508MS02	Affiliate Marketing and Google Adsense	2		1	3	50	50	100	

Minor Elective Courses (MIEC)

Minor Electives	FinTech & Digital Finance	Product Strategy & Innovation Management	Business Sustainability & Leadership	International Business & Cross-Cultural Management	Entrepreneurship & Start-up Management
MIEC-I	Blockchain & Cryptocurrencies in Financial Services	Strategic Product Management	Sustainable Business Models & Circular Economy	Global Markets & International Strategy	New Venture Planning & Funding Models
MIEC-II	Digital Payment Systems & FinTech Innovations	Agile Frameworks for Business Innovation	ESG Metrics, Reporting & Compliance	Managing Across Cultures & Borders	Lean Start-up & MVP Strategy
MIEC-III	AI & Algorithmic Trading	Innovation and New Product Development	Transformational Leadership & Change Management	International Trade Finance & Risk Management	Business Model Innovation & Growth Hacking

FinTech & Digital Finance										
Course Code	Course Title	L	T	P	C	CIE	SEE	Total	Pre-requisite	
2508MS09	Blockchain & Cryptocurrencies in Financial Services	2		1	3	50	50	100	-	
2508MS30	Digital Payment Systems & FinTech Innovations	2		1	3	50	50	100		
2508MS04	AI & Algorithmic Trading	2		1	3	50	50	100		

Product Strategy & Innovation Management										
Course Code	Course Title	L	T	P	C	CIE	SEE	Total	Pre-requisite	
2508MS82	Strategic Product Management	2		1	3	50	50	100	-	
2508MS03	Agile Frameworks for Business Innovation	2		1	3	50	50	100		
2508MS45	Innovation and New Product Development	2		1	3	50	50	100		

Business Sustainability & Leadership									
Course Code	Course Title	L	T	P	C	CIE	SEE	Total	Pre-requisite
2508MS86	Sustainable Business Models & Circular Economy	2		1	3	50	50	100	-
2508MS35	ESG Metrics, Reporting & Compliance	2		1	3	50	50	100	
2508MS88	Transformational Leadership & Change Management	2		1	3	50	50	100	

International Business & Cross-Cultural Management									
Course Code	Course Title	L	T	P	C	CIE	SEE	Total	Pre-requisite
2508MS39	Global Markets & International Strategy	2		1	3	50	50	100	-
2508MS59	Managing Across Cultures & Borders	2		1	3	50	50	100	
2508MS49	International Trade Finance & Risk Management	2		1	3	50	50	100	

Entrepreneurship & Start-up Management									
Course Code	Course Title	L	T	P	C	CIE	SEE	Total	Pre-requisite
2508MS68	New Venture Planning & Funding Models	2		1	3	50	50	100	-
2508MS53	Lean Start-up & MVP Strategy	2		1	3	50	50	100	
2508MS14	Business Model Innovation & Growth Hacking	2		1	3	50	50	100	

Ability Enhancement Course (AEC)									
Course Code	Course Title	L	T	P	C	CIE	SEE	Total	Pre-requisite
2508MS83	Student Activity Based Learning				2	-	-	-	-
	Total				2				

Summer Internship (SI)									
Course Code	Course Title	L	T	P	C	CIE	SEE	Total	Pre-requisite
2508MS84	Summer Internship			4	4	100	-	100	-
	Total				4				

Capstone Project (CPROJ)									
Course Code	Course Title	L	T	P	C	CIE	SEE	Total	Pre-requisite
2508MS18	Capstone Project			4	4	50	50	100	-
	Total				4				

Mandatory Courses (MC)

Course Code	Course Title	L	T	P	C	CIE	SEE	Total	Pre-requisite
2508AC12	Sustainable Development for Business	2				100	-	100	-
2508AC03	Corporate Readiness-I	2				100	-	100	-
2508AC04	Corporate Readiness-II	2				100	-	100	CR-I
2508AC05	Corporate Readiness-III	2				100	-	100	CR-II
2508AC01	Aptitude Training	2				100	-	100	-
2508AC06	Design Thinking and Innovation	2				100	-	100	-
2508AC02	Business Management Tools	2				100	-	100	-
2508AC10	Intellectual Property Rights	2				100	-	100	-
2508AC11	Project Management	2				100	-	100	-
2508AC07	Employability Skills-I	2				100	-	100	-
2508AC08	Employability Skills-II	2				100	-	100	ES-I
2508AC09	Employability Skills-III	2				100	-	100	ES-II
	Total					0			

Students must opt for two of the Mandatory Courses per semester compulsorily.

2025 MBA CURRICULUM
Pre - Requisite Flow Chart

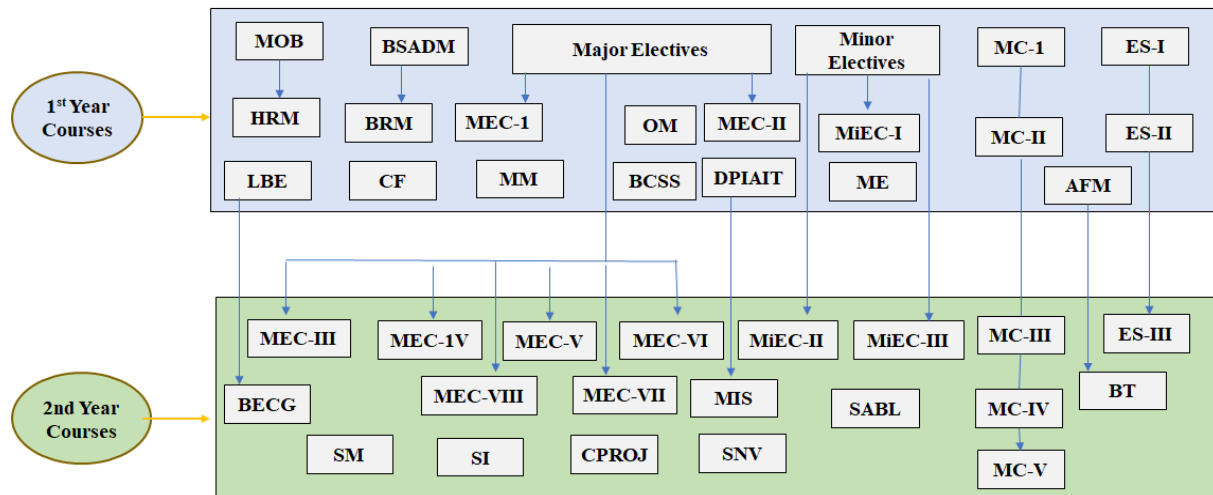

I Year Courses	
MOB	Management and Organization Behavior
AFM	Accounting for Managers
ME	Managerial Economics
BSAD	Business Statistics and Analysis for Decision Making
LBE	Legal and Business Environment
MM	Marketing Management
DPIAIT	Digital Productivity in AI Tools
CF	Corporate Finance
HRM	Human Resource Management
BRM	Business Research Methodology
OM	Operations Management
BCSS	Business communication and soft skills
MC	Mandatory Courses
ES	Employability Skills
II Year Courses	
S&NV	Startup & New Venture
BECG	Business Ethics and Corporate Governance
MIS	Management Information Systems
SM	Strategic Management
BT	Business Taxation
SI	Summer Internship
CPROJ	Capstone Project
SABL	Student Activity Based Learning
Major Electives	
FIN	Finance
MRKG	Marketing
HR	Human Resource
BA	Business Analytics
LSC	Logistics and Supply Chain
DTI	Digital Transformation and Innovation
DM	Digital Marketing
Minor Electives	
FTDF	FinTech & Digital Finance
PSIM	Product Strategy & Innovation Management
BSL	Business Sustainability & Leadership
IBCCM	International Business & Cross-Cultural Management
ESM	Entrepreneurship & Start-up Management

Suggestive Semester- wise Curriculum

SEMESTER-I								
Course Code	Course Title	Course Category	Credits				Total Hours	Pre-requisite
			L	T	P	Total		
2508MS56	Management and Organization Behavior	PCC	2		1	3	4	-
2508MS01	Accounting for Managers	PCC	3	1		4	5	-
2508MS58	Managerial Economics	PCC	2		1	3	5	-
2508MS16	Business Statistics and Analysis for Decision Making	PCC	3	1		4	5	-
2508MS54	Legal and Business Environment	PCC	2		1	3	4	-
2508MS64	Marketing Management	PCC	2		1	3	4	-
2508MS31	Digital Productivity in AI Tools	PCC	2		1	3	4	-
2508AC07	Employability Skills-I	MC	2				3	-
-----	Mandatory Course-I	MC	2				2	-
Total						23	36	

SEMESTER-II								
Course Code	Course Title	Course Category	Credits				Total Hours	Pre-requisite
			L	T	P	Total		
2508MS24	Corporate Finance	PCC	2		1	3	4	-
2508MS42	Human Resource Management	PCC	2		1	3	4	MOB
2508MS15	Business Research Methodology	PCC	3	1		4	5	BSADM
2508MS69	Operations Management	PCC	2		1	3	4	-
-----	Major Elective Course –I	MEC	2		1	3	4	-
-----	Major Elective Course –II	MEC	2		1	3	4	-
-----	Minor Elective Course –I	MiEC	2		1	3	4	-
2508MS12	Business communication and soft skills	PCC	2			2	2	-
2508AC08	Employability Skills-II	MC	2				3	ES-I
-----	Mandatory Course-II	MC	2				2	-
Total						24	36	

SEMESTER-III								
Course Code	Course Title	Course Category	Credits				Total Hours	Pre-requisite
			L	T	P	Total		
2508MS78	Startup & New Venture	PCC	2		1	3	4	-
2508MS13	Business Ethics and Corporate Governance	PCC	2		1	3	4	LBE
2508MS57	Management Information Systems	PCC	2		1	3	4	DPIAIT
-----	Major Elective Course-III	MEC	2		1	3	4	-
-----	Major Elective Course –IV	MEC	2		1	3	4	-
-----	Major Elective Course –V	MEC	2		1	3	4	-
-----	Minor Elective Course –II	MiEC	2		1	3	4	-
2508MS84	Summer Internship	SI			4	4		-
2508AC09	Employability Skills-III	MC	2				3	ES-II
2508AC05	Mandatory Course-III	MC	2				2	-
Total						25	33	

SEMESTER-IV								
Course Code	Course Title	Course Category	Credits				Total Hours	Pre-requisite
			L	T	P	Total		
2508MS80	Strategic Management	PCC	2		1	3	4	-
2508MS17	Business Taxation	PCC	2		1	3	5	AFM
-----	Major Elective Course –VI	MEC	2		1	3	4	-
-----	Major Elective Course –VII	MEC	2		1	3	4	-
-----	Major Elective Course-VIII	MEC	2		1	3	4	-
-----	Minor Elective Course –III	MiEC	2		1	3	4	-
2508MS18	Capstone Project	CPROJ			4	4		SI
-----	Mandatory Course-IV	MC	2				2	-
-----	Mandatory Course-V	MC	2				2	-
2508MS83	Student Activity Based Learning	AEC				2		-
Total						24	29	

MANAGEMENT AND ORGANIZATION BEHAVIOR

Course Code: 2508MS56

L	T	P	C
2		1	3

Course Outcomes:

At the end of the Course, Student will be able to:

- CO1:** Explain the concepts, functions, and evolving challenges of management in 21st-century organizations.
- CO2:** Apply foundational theories of Organizational Behavior to assess individual and group dynamics within organizations.
- CO3:** Analyze various motivation theories and recommend suitable strategies to enhance workplace motivation and performance.
- CO4:** Differentiate between leadership styles and evaluate their effectiveness across diverse and virtual team environments.
- CO5:** Apply techniques to manage organizational culture, conflict, stress, and change for improving organizational effectiveness.

Mapping of Course Outcomes with Program Outcomes:

CO / PO	PO1	PO2	PO3	PO4	PO5	PO6	PO7	PO8
CO1	3	1	1	1	1	1	1	1
CO2	3	3	2	1	2	1	1	1
CO3	3	3	3	3	2	1	1	1
CO4	3	3	3	3	3	1	1	1
CO5	3	3	3	3	3	-	-	-

Mapping of Course Outcomes with Program Specific Outcomes:

CO / PSO	PSO1	PSO2	PSO3
CO1	3	1	1
CO2	3	2	1
CO3	3	3	2
CO4	3	3	2
CO5	3	3	3

UNIT – I

Management Concept and Functions: Definition, Nature and Importance of Management, Evolution of Management thought, Levels of Management, Functions of Management- Planning, Organizing, Staffing, Directing, and Controlling. Managerial roles, Challenges of managing 21st century corporations/organization.

UNIT – II

Foundations of Organizational Behavior: Management and Organizational Behavior, Individual Behavior characteristics, Personality, Personality types, Personality traits, Perception, Attitude and Learning; Interpersonal Behavior, Communication and Transactional Analysis and Johari Window; OB Models; Foundations of Group behavior, formation of groups, Groups versus Teams, Group dynamics.

UNIT – III

Motivation: Meaning, Definition, Importance of Motivation in Organizational Behaviour, Types of Motivation, Work motivation, need theories, Theory X – Theory Y, Two Factor Theory, Ouchi's theory Z, Alderfer's ERG theory, McClelland's theory, Vroom's expectancy theory, Adams equity theory, contemporary issues in the practice of motivation, Recent Trends in Motivation.

UNIT – IV

Leadership: Introduction to Leadership, Leadership vs Management, Theories, Leadership Styles, Emotional Intelligence, Ethical Leadership, Cross-Cultural Leadership, Leadership Development, Crisis Leadership, Virtual Team Leadership, Power and Politics.

UNIT – V

Management of Organizational Behavior: Organizational culture, managing conflict, work stress and its management, work-life balance; Managing change- nature, forces, resistance and resolution

Textbooks:

1. Dr. Chandrani Singh (2024), Principles and Practices of Management and Organizational Behavior. Routledge India; 1st edition, ISBN 978-1032634241.
2. Stephen P. Robbins, Timothy A. Judge and Neharika Vohra (2022) Organizational Behavior, 18e, 978-9356064270. Pearson Education

Reference Books:

1. Kavita Singh (2024) Organizational Behaviour: Text and Cases, Pearson India, ISBN 13: 978-1282652729
2. Laurie J. Mullins and Gary Rees (2023) Management and Organizational Behaviour (13th Edition), ISBN-13: 978-1292422381. Pearson Education Limited.

Web Links:

1. <https://archive.nptel.ac.in/courses/110/107/110107150/>
2. <https://archive.nptel.ac.in/courses/110/106/110106145/>

Relevant cases have to be discussed in each unit and in examination case study is compulsory from any unit.

ACCOUNTING FOR MANAGERS

Course Code: 2508MS01

L	T	P	C
3	1		4

Course Outcomes:

At the end of the Course, Student will be able to:

- CO1:** Explain accounting concepts, principles, standards, and the accounting cycle.
- CO2:** Prepare final accounts and apply methods of fixed assets and depreciation accounting.
- CO3:** Apply cost accounting principles including cost sheet preparation and inventory control.
- CO4:** Analyze budgeting techniques like performance, fixed, flexible, and zero-based budgeting.
- CO5:** Evaluate decisions using financial statement analysis, ratio analysis, and marginal costing.

Mapping of Course Outcomes with Program Outcomes:

CO / PO	PO1	PO2	PO3	PO4	PO5	PO6	PO7	PO8
CO1	3	2	2	1	1	1	1	1
CO2	3	3	2	1	2	1	1	1
CO3	3	3	3	2	1	1	1	1
CO4	3	3	3	3	2	1	1	-

Mapping of Course Outcomes with Program Specific Outcomes:

CO / PSO	PSO1	PSO2	PSO3
CO1	3	2	1
CO2	3	3	1
CO3	3	3	2
CO4	3	3	2
CO5	3	3	3

UNIT – I

Financial Accounting: Scope and Nature of Accounting, Accounting concepts, Principles & Standards, Accounting Cycle, Journalizing, Subsidiary Books; Ledger Posting, Preparation of Trial Balance, Rectification of Errors. Capital and Revenue Expenditure & Income.

UNIT – II

Depreciation and Final Accounting: Fixed Assets and Depreciation Accounting. Preparation of Final Accounts, Manufacturing Account; Trading Account, Profit and Loss Account; Balance Sheet (with adjustments), Financial Statements.

UNIT – III

Cost Accounting: Objectives, Classification of Cost, Preparation of Cost Sheet, Material Cost Accounting, Perpetual Inventory Control, Inventory Valuation, EOQ, ABC Analysis.

UNIT – IV

Performance Evaluation Techniques: Introduction to Budgeting and Budgetary Control; Performance Budgeting; Classification of Budget; Fixed and Flexible Budgets, Zero Based Budgeting.

UNIT – V

Decision Making Techniques: Financial Statement Analysis, Ratio Analysis, Common Size Statements, Du Pont Analysis, Marginal Costing, Application of Marginal Costing in Decision Making, Cost Volume Profit Analysis, Fundamentals of standard costing.

Text Books:

1. Sanjay Dhamija, Financial Accounting for Managers (4th Edition) (2024), ISBN- 13: 978-9357054898, Pearson India.
2. Paul D. Kimmel, Jerry J. Weygandt, and Jill E. Mitchell, Financial Accounting for Managers, (2023) ISBN- 13: 978-1119811428 Wiley.

Reference Books:

1. Peter D. Easton, Robert F. Halsey, Mary Lea McAnally, Al L. Hartgraves, and Wayne J. Morse, Financial & Managerial Accounting for MBAs (7th Edition) (2025), ISBN - 13: 978-1618536211, Cambridge Business Publishers
2. Ray H. Garrison, Eric Noreen, and Peter C. Brewer, Managerial Accounting (17th Edition), (2021), ISBN- 13: 978-1260247787, McGraw Hill Education.

Web Links:

1. <https://archive.nptel.ac.in/courses/110/101/110101003/>
2. <https://nptel.ac.in/courses/110101004>

Relevant cases have to be discussed in each unit and in examination case study is compulsory from any unit.

MANAGERIAL ECONOMICS

L T P C
2 1 3

Course Code: 2508MS58

Course Outcomes:

At the end of the Course, Student will be able to:

- CO1:** Explain the nature, scope, and key concepts of managerial economics and its relation to other economic areas.
- CO2:** Analyze demand and supply concepts, elasticity, and demand forecasting techniques.
- CO3:** Apply production theories and functions, including returns to scale and laws of returns.
- CO4:** Examine cost concepts, cost-output relationships, economies of scale, and breakeven analysis.
- CO5:** Evaluate market structures, pricing methods, market failures, and core macroeconomic indicators.

Mapping of Course Outcomes with Program Outcomes:

CO / PO	PO1	PO2	PO3	PO4	PO5	PO6	PO7	PO8
CO1	3	2	2	1	1	1	1	1
CO2	3	3	2	1	2	1	1	1
CO3	3	3	3	2	2	1	1	1
CO4	3	3	3	3	3	1	1	1
CO5	3	3	3	3	3	2	1	1

Mapping of Course Outcomes with Program Specific Outcomes:

CO / PSO	PSO1	PSO2	PSO3
CO1	3	2	1
CO2	3	3	1
CO3	3	3	2
CO4	3	3	2
CO5	3	3	3

UNIT – I

Introduction to Managerial Economics: Definition, Nature and Scope, Relationship with other areas in Economics, The role of managerial economist. Concept of opportunity cost, Incremental concept, time Perspective, Discounting Principle, Risk & uncertainty, Equimarginal Principle, Concept of Utility.

UNIT – II

Demand Analysis: Introduction to Demand, Law of Demand, Determinants of Demand, Demand Function, Elasticity of demand, types and significance of Elasticity of Demand - Measurement of price Elasticity of Demand – Need for Demand forecasting, forecasting techniques, Law of Supply, Elasticity of Supply.

UNIT – III

Production Analysis: Production function, Types of Production, Factors of Production, Law of Variable Proportion, Isoquant and Isocost, Marginal Rate of Technical Substitution, Production functions with one/two variables, Cobb-Douglas Production Function, Returns to Scale and Laws of Returns.

UNIT – IV

Cost Theory and Estimation: Cost concepts, determinants of cost, cost – output relationship in the short run and long run –Economies and Diseconomies of Scale, Breakeven Point, Cost - Volume – Profit analysis.

UNIT – V

Market Structure and Pricing Practices: Features and types of different Markets – Price- Output determination in Perfect competition, Monopoly, Monopolistic competition and Oligopoly both in the long run and short run. Pricing methods in practice.

Market Failures: definition, types, causes, effects and corrective measures to market failures.

Macroeconomics: National income-definition, concepts, measurement of national income, Trade cycles, Monetary policy, Fiscal policy, inflation and balance of payment.

Text Books:

1. Dominick Salvatore & Siddhartha K. Rastogi, Managerial Economics: Principles and Worldwide Applications (9th Edition) (2020), Oxford University Press ISBN-13: 978-0199496563.
2. William F. Samuelson, Stephen G. Marks, & Jay L. Zagorsky, Managerial Economics (9th Edition)(2021) John Wiley & Sons, ISBN 13: 978-1119554912

Reference Books:

1. Nick Wilkinson, Managerial Economics: Problem-Solving in a Digital World (2nd Edition) (2022) Cambridge University Press, ISBN- 13: 978-1108984508.
2. Satya P. Das, Managerial Economics (2nd Edition) (2022), SAGE Publications India, ISBN-13: 978-9354791802.

Web Links:

1. <https://archive.nptel.ac.in/courses/110/101/110101149/>
2. <https://archive.nptel.ac.in/courses/110/105/110105075/>

Relevant cases have to be discussed in each unit and in examination case study is compulsory from any unit.

BUSINESS STATISTICS AND ANALYSIS FOR DECISION MAKING

	L	T	P	C
Course Code: 2508MS16	3	1		4

Course Outcomes:

At the end of the Course, Student will be able to:

- CO1:** Explain the types of data and types of variables
- CO2:** Apply various concepts of descriptive statistics
- CO3:** Analyze the theories of probability
- CO4:** Solve the problems related to Linear programming.
- CO5:** Evaluate various transportation models and game theory.

Mapping of Course Outcomes with Program Outcomes:

CO / PO	PO1	PO2	PO3	PO4	PO5	PO6	PO7	PO8
CO1	3	2	2	1	1	1	1	1
CO2	3	3	2	2	2	1	1	1
CO3	3	3	3	2	2	1	1	1
CO4	3	3	3	3	3	1	1	1
CO5	3	3	3	3	3	2	1	1

Mapping of Course Outcomes with Program Specific Outcomes:

CO / PSO	PSO1	PSO2	PSO3
CO1	3	2	1
CO2	3	3	1
CO3	3	3	2
CO4	3	3	2
CO5	3	3	3

UNIT – I

Introduction to Business Statistics: Introduction to Statistics, Statistics in Business, Types of data – Nominal, Ordinal, Interval, Ratio. Types of variables – Dependent, independent, moderating, intervening, extraneous. Discrete / continuous. Charts and Graphs.

UNIT – II

Descriptive Statistics: Measure of central tendency – mean, median, quartile, mode (for Group and ungrouped data) Measure of variability – Range, interquartile range, standard deviation, variance, coefficient of variation, (for Group and ungrouped data) Measures of shape – kurtosis, skewness, boxplot.

UNIT – III

Introduction to Probability: Theories of probability – Classical, Relative frequency and subjective. Laws of probability – addition, multiplication. Inverse Probability. Revision of probability: BAYES' RULE, Discrete distribution – Binomial, Poisson, Continuous distribution – Uniform, normal.

UNIT – IV

Introduction to Linear Programming problems (LP) – LP Formulations – Graphical Solution – Simplex Method

UNIT – V

Classification of Models- Introduction –Transportation Models NWCR, LCM, VAM –MODI Method- Assignment Problem- Game theory: Saddle Point Determination, Dominance Property, Two Person Zero–sum Game

Text Books:

1. Ken Black, Business Statistics: For Contemporary Decision Making (11th Edition), John Wiley & Sons,(2023) ISBN- 13: 978-1119905448
2. S. Christian Albright & Wayne L. Winston, Business Analytics: Data Analysis and Decision Making (7th Edition), (2020), Cengage Learning, ISBN- 13: 978-0357392072.

Reference Books:

1. S. D. Sharma, Operations Research, 2020, Kedar Nath, Ram Nath & Co., Meerut, ISBN: 9788178849376.
2. David F. Groebner, Patrick W. Shannon, Phillip C. Fry, Business Statistics: A Decision-Making Approach (11th Edition): Pearson, ISBN- 13: 978-0137835393

Web Links:

1. <https://archive.nptel.ac.in/courses/110/107/110107114/>
2. <https://archive.nptel.ac.in/noc/courses/noc21/SEM1/noc21-mg07/>

Relevant cases have to be discussed in each unit and in examination case study is compulsory from any unit.

LEGAL AND BUSINESS ENVIRONMENT

Course Code: 2508MS54

L	T	P	C
2		1	3

At the end of the Course, Student will be able to:

- CO1:** Explain the steps and procedures for the incorporation of a company and the appointment of directors.
- CO2:** Appraise the legality of object, unlawful and illegal agreements, contingent contracts, and the performance and discharge of contracts.
- CO3:** Analyze the offences by companies, amendments to the act, and RBI guidelines on digital transactions.
- CO4:** Evaluate the industrial policy, five-year planning and foreign direct investment (FDI).
- CO5:** Analyze the impact and effectiveness of these laws and regulations on business practices.

Mapping of Course Outcomes with Program Outcomes:

CO/PO	PO 1	PO 2	PO 3	PO 4	PO 5	PO 6	PO 7	PO 8
CO1	3	2	2	1	1	1	1	1
CO2	3	3	2	1	2	1	1	1
CO3	3	3	3	2	1	1	1	1
CO4	3	3	3	3	2	1	1	1
CO5	3	3	3	3	3	2	1	1

Mapping of Course Outcomes with Program Specific Outcomes:

CO/PSO	PSO1	PSO2	PSO3
CO1	3	2	1
CO2	3	3	1
CO3	3	3	2
CO4	3	3	2
CO5	3	3	3

UNIT – I

Companies Act, 2013, Steps and Procedure for Incorporation of a Company, Appointment of Directors, Powers, Duties, & Liabilities of Directors, Role of Audit and Auditors, Change of Auditors, Related Party Transactions, Company Meetings, Resolutions, Winding-up of a Company.

UNIT – II

Law of Contract: Nature and Types of Contract and Essential Elements of Valid Contract, Offer and Acceptance, Consideration, Capacity to Contract and Free Consent, Legality of Object. Unlawful and illegal Agreements, Contingent Contracts, Performance and Discharge of Contracts, Remedies for Breach of Contract. Contracts-II: Indemnity and Guarantee, Contract of Agency, Sale of Goods Act-1930: General Principles, Conditions & Warranties, Performance of Contract of Sale, Auction Sale and E-Auctions.

UNIT – III

Negotiable Instruments Act - 1881: Negotiable Instruments, Promissory Note, Bills of Exchange, & Cheque, Parties to Negotiable Instruments, Types of Endorsements, Holder, Holder in Due-course, Dishonor and Discharge of Negotiable Instruments, Offences by the Companies, Amendments, RBI Guidelines on Digital Transactions.

UNIT – IV

Business Environment: Industrial Policy, Five Year Planning, Foreign Direct Investment (FDI), Fiscal Policy, Latest Union Budget, Reforms Undertaken by the Government, Monetary Policy, Banking Sector Reforms, NITI Aayog, Responsibilities and Functions.

UNIT – V

Business Regulations and Environment Laws: a) Consumer Protection Act 2019, Information Technology Act 2000, Cyber Security Competition Act 2002, Intellectual Property Rights. b) Environmental Law: Water, Air Pollution, Green Tribunal in Protecting Environment, Sustainability Reporting Practices.

Text Books:

1. Rajdeep Banerjee, Joyeeta Banerjee, Legal Aspects of Business, Sage Publications, 1e, 2022, ISBN-10: 9354793177.
2. Ravinder Kumar, Legal Aspects of Business, Cengage Learning, 5e, 2021, ISBN-13: 9978-8131531594.

Reference Books:

1. Francis Cherunilam, Business Environment Text & Cases, Himalaya Publications, 13e, 2022, ISBN-13: 978-9352994427.
2. Akhileshwar Pathak, Legal Aspects of Business, TMH, 7e, 2019, ISBN-13: 9789-9355322081.

Web Links:

1. <https://archive.nptel.ac.in/courses/110/107/110107145/>
2. https://onlinecourses.swayam2.ac.in/imb22_mg02/preview

Relevant cases have to be discussed in each unit and in examination case study is compulsory from any uni

MARKETING MANAGEMENT

Course Code: 2508MS64

L	T	P	C
2		1	3

Course Outcomes:

At the end of the Course, Student will be able to:

- CO1:** Explain marketing and the core marketing concepts
- CO2:** Select market segments based on effective segmentation criteria
- CO3:** Analyze products, the product life cycle, and propose strategies for new product development
- CO4:** Assess pricing strategies, the relevance of the value chain to marketing, and customer lifetime value
- CO5:** Evaluate integrated marketing channels, manage retailing and logistics, and the effectiveness of various promotional strategies

Mapping of Course Outcomes with Program Outcomes:

CO/PO	PO1	PO2	PO3	PO4	PO5	PO6	PO7	PO8
CO1	3	2	2	3	2	2	1	1
CO2	3	3	2	3	2	2	1	1
CO3	3	3	3	2	2	3	2	2
CO4	3	3	3	3	2	2	3	2
CO5	3	3	2	2	3	3	3	2

Mapping of Course Outcomes with Program Specific Outcomes:

CO/PSO	PSO1	PSO2	PSO3
CO1	3	2	1
CO2	3	3	2
CO3	3	2	3
CO4	3	3	2
CO5	3	3	3

UNIT – I

Understanding Marketing World: Defining Marketing for the New Realities - The Scope of Marketing - Core Marketing Concepts - Marketing Environment; Selling Vs Marketing; Company Orientation toward the Marketplace; Marketing Mix.

UNIT – II

Segmentation, Targeting and Positioning: Segmentation - Bases for Segmenting Consumer Markets - Geographic Segmentation - Demographic Segmentation - Psychographic Segmentation - Behavioral Segmentation - Market Targeting; Effective Segmentation Criteria - Evaluating and Selecting the Market Segments – Positioning.

UNIT – III

Product Concept and Brand Management: Setting Product Strategy - Product Classification, Product Levels, Product Line and Mix Concept, Product Life Cycle and New Product Development - Introducing New Market Offerings - Building Loyalty - Brand Communities - Win-Backs - Cultivating Customer Relationships - Customer Relationship Management.

UNIT – IV

Pricing, Value Chain and Customer Value: Developing Pricing Strategies and Programs – Understanding the Value Chain and its Relevance to Marketing – Managing Customer Value; The Value Delivery Process – The Value Chain – Building Customer Value, Satisfaction, and Loyalty – Measuring Customer Life Time Value and – Retaining Customers.

UNIT – V

Distribution and Promotion: Designing and Managing Integrated Marketing Channels – Managing Retailing, Wholesaling and Logistics. Designing and Managing Integrated Marketing Communications – Managing Mass Communications: Advertising, Sales Promotions, Events and Experiences and Public Relations, Omni Channel Strategy, Marketing Metrics, Neuro Marketing.

Text Books:

1. Kotler, P., Keller, K. L., & Chernev, A. (2021). Marketing management (16th ed.). Pearson. ISBN: 9781292404813
2. Marshall, G. W., & Johnston, M. W. (2021). Marketing management (4th ed.). McGraw Hill Education. ISBN: 9781260381917

Reference Books:

1. Iacobucci, D. (2021). Marketing management (6th ed.). Cengage Learning. ISBN: 9780357635087.
2. Czinkota, M. R., Kotabe, M., Vrontis, D., & Shams, S. M. R. (2021). Marketing management: Past, present and future (4th ed.). Springer. ISBN: 9783030669157.

Web Links:

1. <https://archive.nptel.ac.in/courses/110/104/110104068/>
2. https://onlinecourses.nptel.ac.in/noc22_mg57/preview

Relevant cases have to be discussed in each unit and in examination case study is compulsory from any unit

DIGITAL PRODUCTIVITY IN AI TOOLS

	L	T	P	C
Course Code: 2508MS31	2		1	3

Course Outcomes:

At the end of the Course, Student will be able to:

- CO1:** Explain advanced Microsoft Word features such as templates, mail merge, and document protection to produce professional business documents.
- CO2:** Analyze business data using Excel functions, pivot tables, and scenario tools for data-driven decision-making.
- CO3:** Design engaging presentations and manage communications effectively using PowerPoint, Outlook, and Microsoft 365 integrations.
- CO4:** Evaluate the relevance, reliability, and ethical use of generative AI tools like ChatGPT, Copilot, and Gemini in business contexts
- CO5:** Create AI-enhanced business solutions using creative and analytical tools for content creation, automation, and visualization.

Mapping of Course Outcomes with Program Outcomes:

CO/PO	PO1	PO2	PO3	PO4	PO5	PO6	PO7	PO8
CO1	3	2	1	2	2	3	3	1
CO2	3	2	1	2	2	2	2	2
CO3	3	2	1	2	2	2	3	2
CO4	3	2	2	2	3	2	3	2
CO5	3	3	3	3	3	3	3	3

Mapping of Course Outcomes with Program Specific Outcomes:

CO/PSO	PSO1	PSO2	PSO3
CO1	3	2	2
CO2	3	2	2
CO3	3	2	3
CO4	3	2	3
CO5	3	3	3

UNIT – I

Advanced Microsoft Word for Business Use: Document formatting, templates, and styles, Table of contents, citations, and referencing, Mail merge and automated forms, Collaborating and reviewing documents, Protecting and securing Word files

UNIT – II

Excel for Business Analytics and Decision Making: Basic to intermediate formulas and functions, Data cleaning, validation, and conditional formatting, Pivot tables and charts, Scenario analysis using What-If tools, Introduction to Excel Macros and automation

UNIT – III

PowerPoint & Outlook for Effective Communication: Slide design principles and templates,

Embedding charts, videos, and animations, Presenter view and smart art for business storytelling, Managing calendar, meetings, and email productivity in Outlook, Integrating OneDrive and Teams with Office tools

UNIT – IV

Generative AI Platforms: Foundations & Business Use Cases: Introduction to ChatGPT, Gemini, Claude, Copilot, Practical applications: report writing, resume building, ideation, Prompt crafting for better AI results, Ethics, privacy, and limitations of generative AI tools, Evaluating reliability and accuracy of AI content

UNIT – V

Creative & Analytical AI Tools for Productivity: AI tools for presentation design: Tome, Beautiful.ai, Gamma, Text-to-speech and AI video editors: Lumen5, ElevenLabs, Music and content creation: Soundraw, Beatoven.ai, AI data tools: Tableau Public, Google Colab, ChatGPT Code Interpreter, Capstone: Build & present a business solution using AI tools

Text Books:

1. Microsoft Office 365: In Practice 2021 Edition, Randy Nordell, McGraw-Hill Education, 2021
2. The Artificial Intelligence Handbook: How AI Is Revolutionizing Business Productivity, Nathan Hunter, Independently Published, 2023

Reference Books:

1. Excel Data Analysis: Your visual blueprint for analyzing data, charts, and PivotTables, Jinjer Simon, Wiley, 2022
2. Slide:ology: The Art and Science of Creating Great Presentations, Nancy Duarte, O'Reilly Media, 2008

Web Links:

1. <https://learn.microsoft.com/en-us/training/>
2. <https://openai.com/>

Relevant cases have to be discussed in each unit and in examination case study is compulsory from any unit.

CORPORATE FINANCE

	L	T	P	C
Course Code: 2508MS24	2		1	3

Course Outcomes:

At the end of the Course, Student will be able to:

- CO1:** Understand the role and scope of the finance function in modern business.
- CO2:** Apply time value of money and valuation models in financial decisions.
- CO3:** Use capital budgeting techniques to evaluate investment decisions.
- CO4:** Analyze capital structure theories and measure cost of capital.
- CO5:** Assess dividend policies and their impact on firm valuation.

Mapping of Course Outcomes with Program Outcomes:

CO/PO	PO1	PO2	PO3	PO4	PO5	PO6	PO7	PO8
CO1	3	2	2	2	2	3	2	2
CO2	3	3	3	2	2	3	2	2
CO3	3	3	3	2	3	3	3	2
CO4	3	3	3	3	2	3	3	2
CO5	3	3	3	3	3	3	2	2

Mapping of Course Outcomes with Program Specific Outcomes:

CO/PSO	PSO1	PSO2	PSO3
CO1	3	2	2
CO2	3	3	2
CO3	3	3	3
CO4	3	3	3
CO5	3	3	3

UNIT – I

The Finance Function: Nature and Scope, Evolution of Finance Function, Its New Role in the Contemporary Scenario, Goals of Finance Function, Profit Maximization and Wealth Maximization; Concept of Time Value of Money, Future Value and Present Value and the Basic Valuation Model.

UNIT – II

The Investment Decision: Investment Decision Process, Project Generation, Evaluation, Selection, Implementation. Developing Cash Flow, Data for New Projects, Capital Budgeting Techniques: Traditional and DCF Methods.

UNIT – III

Capital Structure and Cost of Capital: Capital Structure Theories: The Modigliani Miller Theory, NI, NOI Theory and Traditional Theory, Cost of Capital: Concept, Importance and Measurement of Cost of Capital, Weighted Average and Marginal Cost of Capital.

UNIT – IV

Dividend Decisions: Factors Determining Dividend Policy, Dividends and Valuation of the Firm, the Basic Models, Forms of Dividend. Declaration and Payment of Dividends. Bonus Shares, Rights Issue, Share splits, Major Forms of Dividends, Cash and Bonus Shares. Dividends and Valuation. Major Theories centered on the works of Gordon, Walter.

UNIT – V

Working Capital Management: Working Capital Management: Components of Working Capital, Gross vs. Net Working capital, Determinants of Working Capital Needs, the Operating Cycle Approach. Financing of Working Capital through Bank Finance and Trade Credit,

Text Books:

1. Ross, S. A., Westerfield, R. W., Jaffe, J., & Jordan, B. D. (2021). Corporate finance (13th ed.). McGraw Hill Education. ISBN: 9781260772388.
2. Brealey, R. A., Myers, S. C., Allen, F., & Edmans, A. (2022). Principles of corporate finance (14th ed.). McGraw Hill Education. ISBN: 9781264080946

Reference Books:

1. Bratton, W. W. (2021). Corporate finance: Cases and materials (9th ed.). West Academic Publishing. ISBN: 9781684679270.
2. Haas, J. J. (2021). Corporate finance (2nd ed.). West Academic Publishing. ISBN: 9781647088651

Web Links:

1. https://onlinecourses.nptel.ac.in/noc20_mg31/preview
2. <https://archive.nptel.ac.in/courses/110/107/110107144/>

Relevant cases have to be discussed in each unit and in examination case study is compulsory from any unit.

HUMAN RESOURCE MANAGEMENT

	L	T	P	C
Course Code: 2508MS42	2		1	3

Course Outcomes:

At the end of the Course, Student will be able to:

- CO1:** Understand the basic concepts, functions, and current trends in Human Resource Management (HRM).
- CO2:** Apply the principles of manpower acquisition, including human resource planning, recruitment, and selection processes.
- CO3:** Design and evaluate training and development programs for employee growth and career development.
- CO4:** Assess performance appraisal techniques and wage and salary administration methods in HRM.
- CO5:** Analyze industrial relations concepts, issues, and the process of managing industrial disputes and collective bargaining.

Mapping of Course Outcomes with Program Outcomes:

CO/PO	PO 1	PO 2	PO 3	PO 4	PO 5	PO 6	PO 7	PO 8
CO1	3	2	2	2	2	2	3	2
CO2	3	3	2	2	3	3	3	2
CO3	3	3	2	3	3	2	3	2
CO4	3	2	3	3	2	3	2	2
CO5	3	3	3	3	2	2	2	3

Mapping of Course Outcomes with Program Specific Outcomes:

CO/PSO	PSO1	PSO2	PSO3
CO1	3	2	2
CO2	3	3	3
CO3	3	3	2
CO4	3	2	3
CO5	3	3	2

UNIT – I

Introduction to Human Resource Management: Introduction, Concept, Definitions, Nature, Scope, Importance and Objectives of HRM, Evolution of HRM, Functions of HRM, Roles and responsibilities of HR Manager, current trends in HR.

UNIT – II

Manpower Acquisition: Concept, Objectives, Importance and Process of HRP, Factors Affecting HRP, Job Analysis- Nature, Methods, Approaches, Job description and job specification, Job Enlargement, Job Enrichment, Job Design, Recruitment- Purpose, Process, Sources, Methods of Recruitment, Selection- Importance and processes of selection, Types of Tests in selection, Interview- Types of Selection Interview. Employee Induction/Orientation, Technologies in HR, Digital Onboarding.

UNIT – III

Training and Development: Meaning, Objectives, Importance of training, Assessment of training, Need for Training, Process of training. Methods of Training, Designing a Training Program, Executive Development, Methods of Executive Development, Internal Mobility and Separation of Employees, Promotion, Transfer, Demotion and Demotion, Succession Planning, Career Planning, Process., Career Development, Career Anchors, Career Life Cycle.

UNIT – IV

Performance Appraisal: Introduction, Meaning, Objectives, Need and Importance of Performance Appraisal, Process of performance appraisal, Methods of performance appraisal.

Wage and Salary Administration: Objectives and Principles, Essentials of a sound wage structure, Methods of wage payments, Incentive Plans, Types of Incentive Plans, and Profit Sharing, Job evaluation, Fringe benefits and Employee Welfare.

UNIT – V

Industrial Relations: Concept, Meaning, Characteristics, Objectives and Approaches of Industrial Relations, Causes and measures for Industrial Relations, Factors influencing Industrial Relations, Industrial Disputes and Settlement, Workers Participation in Management, Collective Bargaining, Grievance Redressal, Conciliation, Adjudication and Arbitration, Trade Unions- Nature, Role and Problems, HRMS, Real world examples of HRMS.

Text Books:

1. Verhulst, S. L., & DeCenzo, D. A. (2021). Fundamentals of human resource management (14th ed.). Wiley. ISBN: 9781119803744
2. Crews, D. (2021). Mastering human resource management (1st ed.). FlatWorld. ISBN: 9781453397077

Reference Books:

1. Blokdyk, G. (2020). Human resource management: A complete guide – 2021 edition. The Art of Service. ISBN: 9781867424604.
2. McConnell, C. R. (2021). Human resource management in health care (3rd ed.). Jones & Bartlett Learning. ISBN: 9781284155136.

Web Links:

1. <https://archive.nptel.ac.in/courses/110/105/110105069/>
2. https://onlinecourses.nptel.ac.in/noc21_mg21/preview

Relevant cases have to be discussed in each unit and in examination case is compulsory from any unit.

BUSINESS RESEARCH METHODOLOGY

	L	T	P	C
Course Code: 2508MS15	3	1		4

Course Outcomes:

At the end of the Course, Student will be able to:

- CO1:** Understand the fundamentals of research, its methodology, and the ethical considerations in business research.
- CO2:** Apply appropriate research designs, sampling techniques, and measurement scales for data collection.
- CO3:** Evaluate and process data using different classification, coding, and graphical methods to ensure accurate data representation.
- CO4:** Formulate and test hypotheses using various statistical methods and tests to draw inferences from data.
- CO5:** Analyze data using multivariate techniques and effectively present research findings in reports.

Mapping of Course Outcomes with Program Outcomes:

CO/PO	PO 1	PO 2	PO 3	PO 4	PO 5	PO 6	PO 7	PO 8
CO1	3	2	2	3	2	1	3	2
CO2	3	3	2	2	3	2	2	3
CO3	3	3	3	3	3	3	2	3
CO4	3	3	3	3	2	3	3	3
CO5	3	3	3	3	3	3	3	3

Mapping of Course Outcomes with Program Specific Outcomes:

CO/PSO	PSO 1	PSO 2	PSO 3
CO1	3	2	2
CO2	3	3	2
CO3	3	3	3
CO4	3	3	3
CO5	3	3	3

UNIT – I

Introduction: Meaning of research, research methodology, scientific research, objectives, Nature and Importance of Research, The role of Business Research, Types of Research, Steps in Research process, criteria for good research, problems by encountered by researchers in India, ethical issues in business research.

UNIT – II

Data Collection: Defining Research Problem, Selection of an appropriate survey research design, types of research designs, sampling design, types of sample designs-Random and non random sample designs, measurement and scaling techniques- Nominal Scale, Ordinal Scale, Interval Scale, Ratio Scale.

UNIT – III

Survey Research and Data Classification: Types of Data, primary data collection methods, secondary data collection methods, Data processing operations-editing, coding, classification, tabulation and Graphic Presentation, problems in data processing, types of data analysis- univariate, bivariate and multivariate.

UNIT – IV

Statistical Inference: Formulation of Hypothesis, Introduction to Null hypothesis vs. alternative hypothesis, Tests of Hypothesis- univariate and bivariate, parametric vs. non-parametric tests, procedure for testing of hypothesis, t tests, Z tests, Chi Square test, ANOVA- one-way & two way.

UNIT – V

Multivariate Analysis: Nature of multivariate analysis, classifying multivariate techniques, analysis of dependence, analysis of interdependence, multiple regression, factor analysis, cluster analysis, discriminant analysis, Report writing.

Text Books:

1. Schindler, P. S. (2021). Business research methods (14th ed.). McGraw Hill Education. ISBN: 9781260733723
2. Hair, J. F., Page, M., & Brunsveld, N. (2023). Essentials of business research methods (5th ed.). Routledge. ISBN: 9780367757793.

Reference Books:

1. Aguinis, H. (2025). Research methodology: Best practices for rigorous, credible, and impactful research. SAGE Publications. ISBN: 9781071839141
2. Gorard, S. (2021). How to make sense of statistics: Everything you need to know about using numbers in social science. SAGE Publications. ISBN: 9781526413826

Web Links:

1. https://onlinecourses.swayam2.ac.in/cec20_mg14/preview
2. <https://archive.nptel.ac.in/courses/110/107/110107080/>

Relevant cases have to be discussed in each unit and in examination case is compulsory from any unit.

OPERATIONS MANAGEMENT

	L	T	P	C
Course Code: 2508MS69	2		1	3

Course Outcomes:

At the end of the Course, Student will be able to:

- CO1:** Understand the nature, scope, and trends in operations management and its relationship with other functions.
- CO2:** Apply principles of product design, process selection, and facility layout in operations.
- CO3:** Evaluate forecasting, capacity planning, and inventory management techniques.
- CO4:** Analyze productivity factors and leverage Industry 4.0 technologies for process improvement.
- CO5:** Assess quality management techniques and tools, including TQM and statistical quality control.

Mapping of Course Outcomes with Program Outcomes:

CO/PO	PO 1	PO 2	PO 3	PO 4	PO 5	PO 6	PO 7	PO 8
CO1	3	2	2	1	3	1	2	1
CO2	3	2	2	3	2	3	2	1
CO3	2	3	3	2	3	3	2	1
CO4	3	2	3	3	3	3	3	1
CO5	3	2	2	2	3	2	3	1

Mapping of Course Outcomes with Program Specific Outcomes:

CO/PSO	PSO 1	PSO 2	PSO 3
CO1	3	2	1
CO2	3	3	2
CO3	3	3	3
CO4	3	3	3
CO5	2	3	3

UNIT – I

Introduction to Operation Management: Nature & Scope of Operation/ Production Management, Relationship with other functional areas, Recent trend in Operation Management, Manufacturing & Theory of Constraint, Types of Production System, Just in Time (JIT) & lean system.

UNIT – II

Product Design & Process Selection: Stages in Product Design process, Value Analysis, Facility location & Layout: Types, Characteristics, Advantages and Disadvantages, Work measurement, Job design.

UNIT – III

Forecasting & Capacity Planning: Methods of Forecasting, Overview of Operation Planning, Aggregate Production Planning, Production strategies, Capacity Requirement Planning, MRP, Scheduling, Supply Chain Management, Purchase Management, Inventory Management.

UNIT – IV

Productivity: Factors, Affecting Productivity, Process Flow Charts, Work Study, Engineering and Behavioral Approaches, Industry 4.0, Tools and Automation, Digital Twins, IOT in SCM.

UNIT – V

Quality Management: Quality- Definition, Dimension, Cost of Quality, Quality Circles Continuous improvement (Kaizen), ISO (9000&14000 Series), Statistical Quality Control: Variable & Attribute, Process Control, Control Charts -Acceptance Sampling Operating Characteristic Curve (AQL, LTPD, Alpha & Beta risk), Total Quality Management (TQM).

Text Books:

1. Stevenson, W. J., & Kull, T. J. (2024). Operations and supply chain management (14th ed.). McGraw Hill Education. ISBN: 9781265322342
2. Heizer, J., Render, B., & Munson, C. (2022). Operations management: Sustainability and supply chain management (14th ed.). Pearson. ISBN: 9780137649136

Reference Books:

1. Nahmias, S., & Olsen, T. (2023). Production and operations analysis (8th ed.). Waveland Press. ISBN: 9781478649234
2. Langabeer, J. R. (2022). Health care operations management: A systems approach (3rd ed.). Jones & Bartlett Learning. ISBN: 9781284194142

Web Links:

1. https://onlinecourses.nptel.ac.in/noc20_me30/preview
2. <https://archive.nptel.ac.in/courses/110/107/110107141/>

Relevant cases have to be discussed in each unit and in examination case study is Compulsory from any unit.

BUSINESS COMMUNICATION AND SOFT SKILLS

	L	T	P	C
Course Code: 2508MS12	2			2

Course Outcomes:

At the end of the Course, Student will be able to:

- CO1:** Explain key managerial skills and personal competencies, including emotional intelligence and negotiation.
- CO2:** Apply team-building and networking skills to manage teams and collaborate across business functions.
- CO3:** Apply interpersonal and supportive communication skills for effective coaching, counselling, and personal interview management.
- CO4:** Analyze effective communication techniques and evaluate strategies for interviews, group discussions, and professional interactions in the context of technological advancements.
- CO5:** Analyze and construct various business documents and apply appropriate etiquette in professional communication and meetings.

Mapping of Course Outcomes with Program Outcomes:

CO / PO	PO 1	PO 2	PO 3	PO 4	PO 5	PO 6	PO 7	PO 8
CO1	2	2	3	3	2	1	1	1
CO2	2	3	3	2	2	1	1	1
CO3	3	2	3	2	2	1	1	1
CO4	2	3	3	3	2	1	1	1
CO5	2	2	2	3	2	1	1	1

Mapping of Course Outcomes with Program Specific Outcomes:

CO / PSO	PSO1	PSO2	PSO3
CO1	1	-	-
CO2	1	-	-
CO3	1	-	-
CO4	1	-	-
CO5	1	-	-

UNIT – I

Introduction to skills & personal skills Importance of competent managers, skills of effective managers, developing self-awareness on the issues of emotional intelligence, self-learning styles, values, attitude towards change, learning of skills and applications of skills– Negotiation and assertiveness skills.

UNIT – II

Team building: Developing teams and team work, advantages of team, leading team, team membership. Team management, networking skills, interaction across business functions Skill development and skill application.

UNIT – III

Building relationship Skills for developing positive interpersonal communication, importance of supportive communication, coaching and counselling, defensiveness and disconfirmation, principles of supportive communications. Personal interview management. Skill analysis and application on above areas. Reflective assessment on dimension of managerial success.

UNIT – IV

Writing CVs & Application Letter, Group discussions, interview, types of interview, candidates' preparation, Interviewers preparation; Impact of Technological Advancement on Business Communication- oral Communication, principles of successful oral communication, two sides of effective oral communication, effective listening, non – verbal communication, Body language, Paralanguage.

UNIT – V

Introduction to business letters, Types of business letter, Layout of business letter, Reports: definition & purpose, types of business reports, reports writing, letter for Job Application, Thank You Letter, Letter of Complaint, Memos. Meetings: need, importance & planning of Meetings, drafting of notice, agenda, minutes & resolutions of Meeting, writing memorandum, press release, press conference, Business etiquettes – netiquettes, telephonic & table etiquettes .

Text Books:

1. Andrew J. Dubrin, Essentials of Management, Thomson Southwestern, 9th edition, 2012, ISBN-13. 978-8131517130
2. Samuel C. Certo and Tervis Certo, Modern management: concepts and skills, Pearson education, 12th edition, 2012. ISBN-10. 0132176319; ISBN-13. 978-0132176316

Reference Books:

1. Harold Koontz and Heinz Wehrich, Essentials of management: An International & Leadership Perspective, 9th edition, Tata McGraw– Hill Education, 2012. ISBN- 978-1259005121
2. P.D. Chaturvedi – *Busines* Communication (Pearson Education, 3st Edition 2006). ISBN-13 978-9332517608

Web Links:

1. <https://archive.nptel.ac.in/courses/110/105/110105052/>
2. <https://nptel.ac.in/courses/110105052>

Relevant cases have to be discussed in each unit and in examination case study is compulsory from any unit

STARTUP AND NEW VENTURE

	L	T	P	C
Course Code: 2508MS78	2		1	3

Course Outcomes:

At the end of the Course, Student will be able to:

- CO1:** Understand the entrepreneurial mindset, strategic perspectives, and growth strategies for entrepreneurial firms.
- CO2:** Analyze various types of business models and revenue models in the context of entrepreneurship.
- CO3:** Conduct a comprehensive feasibility study covering technical, market, financial, organizational, and legal aspects.
- CO4:** Identify and analyze target customer segments using various segmentation approaches and market research techniques.
- CO5:** Evaluate and strengthen business models using SWOT analysis, Porter's Five Forces, and market positioning strategies.

Mapping of Course Outcomes with Program Outcomes:

CO/PO	PO 1	PO 2	PO 3	PO 4	PO 5	PO 6	PO 7	PO 8
CO1	3	2	2	3	3	2	2	3
CO2	2	3	2	3	3	2	3	3
CO3	3	2	3	2	2	3	2	3
CO4	3	3	3	3	3	3	3	3
CO5	3	3	3	3	3	3	3	3

Mapping of Course Outcomes with Program Specific Outcomes:

CO/PSO	PSO1	PSO2	PSO3
CO1	3	3	2
CO2	2	3	3
CO3	3	2	3
CO4	3	3	3
CO5	3	3	3

UNIT – I

Entrepreneurial Mindset and Strategic Perspectives: Evolution and Role of Entrepreneurship, Entrepreneurial Qualities and Skills, Types and Functions of Entrepreneurs, Approaches and Process of Entrepreneurship, Entrepreneurial Journey and Personality, Motivations and Competencies, Entrepreneurial Stress, Strategic Planning and Positioning, Business Stabilization, Adaptive and Growing Firms, Growth Strategies (Internal & External), Managerial Challenges in Growth.

UNIT – II

Business Model Basics: Introduction to Business Models-Types of Business Models-Traditional v/s New age business Model, Revenue Models: Introduction of the types of revenue models, Advertising Model, Affiliate Model, Selling Real Model- Web Sales, Channel Sales, Retail Sales Model, Selling Virtual model-Freemium Model, Licensing Model, Subscription Model, aggregator business models (OLA, UBER)

UNIT – III

Feasibility Study: Meaning and Importance of Feasibility Study, Steps in Conducting a Feasibility Study, Technical Feasibility, Market Feasibility, Financial Feasibility, Organizational Feasibility, Legal and Regulatory Feasibility, Market Analysis, Demand Forecasting, Cost Estimation, Revenue Projections, Break-even Analysis, SWOT Analysis, Sensitivity Analysis, Components of a Feasibility Report, Feasibility vs Business Plan, Common Mistakes in Feasibility Studies.

UNIT – IV

Segment Profiling: Geographic / Demographic, Behavioural / Psychographic, Target Segment, Customer Segment, Size / TAM, Segment Profiling, Types of Segment Profiling, Different Approaches to Segment Profiling, Market Research Techniques for Understanding Customer Segments, Competitive Activity, Risks, Approach to deal with existing risk

UNIT – V

Evaluating Strength of Business Model: SWOT Analysis, Porter's Five Forces Analysis, Marketing Strategies-Market positioning, Tangible and perceived value of a product, Exploring International Markets and Global Expansion, Growth Potential: Target Segment Collaboration, , **Failure of Business model:** Reasons why does a business model fail, Approaches to revive the failure of business model

Text Books:

1. Allen, K. R. (2021). Launching new ventures: An entrepreneurial approach (8th ed.). Cengage Learning. ISBN: 9780357039175
2. Neck, H. M., Neck, C. P., & Murray, E. L. (2023). Entrepreneurship: The practice and mindset (3rd ed.). SAGE Publications. ISBN: 9781071884874

Reference Books:

1. Shepherd, D. A., & Patzelt, H. (2021). Entrepreneurial strategy: Starting, managing, and scaling new ventures. Palgrave Macmillan. ISBN: 9783030789343.
2. Kuratko, D. F., & Hornsby, J. S. (2021). New venture management: The entrepreneur's roadmap (3rd ed.). Routledge. ISBN: 9780367466725

Web Links:

1. https://onlinecourses.nptel.ac.in/noc22_mg32/preview
2. <https://elearn.nptel.ac.in/shop/iit-workshops/ongoing/innovation-and-entrepreneurship-a-multidisciplinary-approach/?v=c86ee0d9d7ed>

Relevant cases have to be discussed in each unit and in examination case is compulsory from any unit.

BUSINESS ETHICS AND CORPORATE GOVERNANCE

	L	T	P	C
Course Code: 2508MS13	2		1	3

Course Outcomes:

At the end of the Course, Student will be able to:

- CO1:** Explain principles of personal and professional ethics, importance and need of business ethics
- CO2:** Identify perspective, major thrust areas and issues of Corporate Governance.
- CO3:** Apply the concepts of ethical decision making in business.
- CO4:** Analyze the factors facilitating globalization, international code of business conduct and role of ethics in the era of globalization.
- CO5:** Determine the role various corporate social responsibility initiatives in business.

Mapping of Course Outcomes with Program Outcomes:

CO/PO	PO 1	PO 2	PO 3	PO 4	PO 5	PO 6	PO 7	PO 8
CO1	3	2	2	3	2	1	1	2
CO2	2	3	2	3	2	1	1	2
CO3	2	3	3	2	2	1	1	2
CO4	3	3	2	3	2	1	1	2
CO5	2	2	2	3	3	1	1	3

Mapping of Course Outcomes with Program Specific Outcomes:

CO/PSO	PSO1	PSO2	PSO3
CO1	3	2	1
CO2	2	3	1
CO3	3	3	2
CO4	3	2	3
CO5	2	3	2

UNIT – I

Introduction to Business Ethics: Definition – Principles of Personal Ethics – Principles of Professional Ethics – The Development of Business Ethics – Importance and Need for Business Ethics – Significance of Business Ethics – Values and Ethics in Business.

UNIT – II

Corporate Governance – Definitions – Historical Perspective of Corporate Governance – Significance of Corporate Governance in Developing Countries – Issues in Corporate Governance – Major thrust areas of Corporate Governance – Indian model of Corporate Governance.

UNIT – III

Ethical Decision Making in Business – Ethical Decision making with Cross – holder conflicts and competition – Applying Moral philosophy to Ethical decision making – Kohlberg’s Model of Cognitive Moral development – Influences on Ethical Decision making

UNIT – IV

Globalization and Business Ethics – Growth of Global Corporations – Factors Facilitating Globalization – Role of Multinational Corporations – International Business Issues – International Codes of Business conduct – Challenges of Globalization in the context of Growing market economies – Key Global issues for Business – Corporate Governance is a pre-requisite for Globalization.

UNIT – V

Corporate Social Responsibility: Definitions of CSR – Models for implementation of CSR – CSR as a business strategy for sustainable development – Advantages of CSR – Scope of CSR – Understanding Social Responsibility of Business – Protecting and Promoting stake holder's interests.

Text Books:

1. Ghillyer, A. (2025). Business ethics now (6th ed.). McGraw Hill Education. ISBN: 9781260262513
2. Kumar, S., & Rai, A. K. (2021). Ethics and corporate governance. Cengage Learning. ISBN: 9789390555840.

Reference Books:

1. Zimmerli, W. C., Holzinger, M., & Richter, K. (Eds.). (2021). Corporate ethics and corporate governance. Springer. ISBN: 9783540708186.
2. Mescher, B. (2021). Quick reference card: Business ethics (2nd ed.). LexisNexis Australia. ISBN: 9780409355819

Web Links:

1. <https://archive.nptel.ac.in/courses/110/105/110105079/>
2. https://onlinecourses.swayam2.ac.in/cec19_mg24/preview

Relevant cases have to be discussed in each unit and in examination case study is compulsory from any unit.

MANAGEMENT INFORMATION SYSTEMS

	L	T	P	C
Course Code: 2508MS57	2		1	3

Course Outcomes:

At the end of the Course, Student will be able to:

- CO1:** Identify the information needs of an organization and a business function
- CO2:** Assess effectiveness of decision-making process and MIS design
- CO3:** Analyze DSS techniques for making effective decisions
- CO4:** Appraise the parameters for information systems process and application
- CO5:** Apply DBMS to attain the goals of the organization

Mapping of Course Outcomes with Program Outcomes:

CO/PO	PO 1	PO 2	PO 3	PO 4	PO 5	PO 6	PO 7	PO 8
CO1	3	2	2	3	1	1	1	2
CO2	3	3	3	2	2	2	1	2
CO3	2	3	3	3	3	2	2	2
CO4	2	2	2	3	3	2	1	2
CO5	3	3	3	2	3	2	1	3

Mapping of Course Outcomes with Program Specific Outcomes:

CO/PSO	PSO1	PSO2	PSO3
CO1	3	2	1
CO2	3	3	2
CO3	3	3	3
CO4	2	2	3
CO5	3	3	3

UNIT – I

Management Information System; Basic Concepts – Organization Structure – Business Functions – Role of MIS – MIS in Business - MIS Developing Process Models - Simon’s Model in Information System – Major Trends in Information Technology.

UNIT – II

Managerial Decision Making and MIS Design: Decision Making Process; Relationship between Decision-Making and MIS; Group Decision Making - Integrating Managerial Levels and Functional areas by MIS-Components of MIS. System and Design; Systems Development Initiate

UNIT – III

Different Methodologies: System Life Cycle Design - Prototype Approach - System Implementation. Decision Support System; Definitions of DSS – Architecture of DSS - Scope of DSS - Characteristic and Capabilities of DSS - Components of DSS – Modules in DSS- Classification of DSS – Steps in Designing a DSS.

UNIT – IV

Information System Applications and Process: MIS applications, DSS – GDSS - DSS applications in E enterprise - Knowledge Management System and Knowledge Based Expert System, Enterprise Model System and E-Business, E- Commerce, E-communication, Business Process Reengineering. Technology of information system: Data process- Transaction and application process; Unified communication and network; Security challenges in E-enterprises; Security threats and vulnerability-Controlling security threat and vulnerability.

UNIT – V

Data Base Management System: Objectives of data base approach- Characters of database, Management systems- Data processing system- Components of DBMS packages, Data base administration, Data models, Data warehouse.

Text Books:

1. Laudon, K. C., & Laudon, J. P. (2021). Management information systems: Managing the digital firm (17th ed.). Pearson. ISBN: 9780136971276.
2. Baltzan, P. (2024). M: Information systems (7th ed.). McGraw Hill Education. ISBN: 9781266609909

Reference Books:

1. Piccoli, G., & Pigni, F. (2022). Information systems for managers: In the digital age (5th ed.). Prospect Press. ISBN: 9781943153848.
2. Valacich, J. S., Schneider, C., & Hashim, M. (2021). Information systems today: Managing in the digital world (9th ed.). Pearson. ISBN: 9780136524656.

Web Links:

1. https://onlinecourses.nptel.ac.in/noc20_mg60/preview
2. <https://archive.nptel.ac.in/courses/122/105/122105022/>

Relevant cases have to be discussed in each unit and in examination case study is compulsory from any unit.

STRATEGIC MANAGEMENT

	L	T	P	C
Course Code: 2508MS80	2		1	3

Course Outcomes:

At the end of the Course, Student will be able to:

- CO1:** Explain the strategic context and terminology and aspects of strategic planning
- CO2:** Analyze the factors involved in strategy formulation and strategic analysis.
- CO3:** Assess the various approaches to strategy implementation
- CO4:** Compare different forms of corporate restructuring
- CO5:** Analyze different techniques of strategic evaluation and control

Mapping of Course Outcomes with Program Outcomes:

CO/PO	PO 1	PO 2	PO 3	PO 4	PO 5	PO 6	PO 7	PO 8
CO1	3	3	2	3	2	1	1	2
CO2	3	3	3	3	2	2	1	2
CO3	2	3	3	2	3	1	1	2
CO4	3	2	2	3	3	2	1	3
CO5	3	2	3	3	3	2	1	3

Mapping of Course Outcomes with Program Specific Outcomes:

CO/PSO	PSO1	PSO2	PSO3
CO1	3	2	1
CO2	3	3	2
CO3	3	3	2
CO4	3	2	3
CO5	3	3	3

UNIT – I

Introduction of Strategic Management: Strategic Context and Terminology; Definition of Strategy; Difference between policy, Strategy and Tactic; strategic planning- Difference between Long Range Planning and Strategic Planning; Characteristics of Strategic Decisions.

UNIT – II

Strategy Formulation: Mission, Vision & Strategic Intent, features of strategic goals. Social Responsibility and ethical decision making; analyzing the business environment: External environment; Porter’s Industry Analysis; Five forces Model. Internal Analysis of the firm, value chain analysis. **Strategic Analysis:** SWOT, BCG Matrix, Ansoff Matrix, PIMS, Market Development, Product Development, Concentration, Horizontal Integration, Vertical Integration, Diversification, Liquidation, Sell-off, Cost Leadership, Differentiation, Focus, Industry Strategies – Fragmented, Emerging, Maturing, Declining.

UNIT – III

Strategy Implementation: Strategy and structure; managing strategic change; establishing strategic controls; Management tools in strategy: Benchmarking; Benchmarking practices worldwide; Reengineering- Systematic approach, clean sheet approach, Reverse Engineering, Balanced Score card, Crisis Management, Strategic Agility – Exports-factors-Export incentives and govt. schemes, business valuation and factors effecting exports and imports.

UNIT – IV

Corporate Restructuring Forms of corporate restructuring; Rational for existence of firms; Organizational forms; Turnaround management; Joint Ventures & Strategic Alliances: Generic motives for a strategic alliance, types of strategic alliances; managing the alliances; Mergers & Acquisitions: Rational for mergers & acquisitions; Mergers types; Divestitures & Spin-offs: Liquidations and spin-offs.

UNIT – V

Strategic Evaluation and Control Strategic Evaluation and Control: Concept, Role, and Barriers; Control Process; Techniques of Strategic Evaluation and Control.

Text Books:

1. Rothaermel, F. T. (2023). Strategic management (6th ed.). McGraw Hill Education. ISBN: 9781264124312
2. Dess, G. G., McNamara, G., Eisner, A. B., & Sauerwald, S. (2023). Strategic management: Text and cases (11th ed.). McGraw Hill Education. ISBN: 9781264124329

Reference Books:

1. Dyer, J. H., Godfrey, P., Jensen, R., & Bryce, D. (2022). Strategic management: Concepts and cases (4th ed.). Wiley. ISBN: 9781119763543
2. David, F. R., David, F. R., & David, M. E. (2023). Strategic management: A competitive advantage approach, concepts and cases (18th ed.). Pearson. ISBN: 9780138168315

Web Links:

1. <https://archive.nptel.ac.in/courses/110/108/110108047/>
2. <https://archive.nptel.ac.in/courses/110/105/110105161/>

Relevant cases have to be discussed in each unit and in examination case study is compulsory from any unit.

BUSINESS TAXATION

	L	T	P	C
Course Code: 2508MS17	2	1		3

Course Outcomes:

At the end of the Course, Student will be able to:

- CO1:** Explain the tax system in India, including the structure and powers of the Union and States to levy taxes.
- CO2:** Analyze the provisions related to small-scale industries and exports under Central Excise.
- CO3:** Assess various infringements of customs law, including offenses and penalties.
- CO4:** Analyze the impact of GST on businesses, including the impact on pricing, supply chain, and tax compliance.
- CO5:** Evaluate the assessment proceedings under GST, including the filing of returns and refunds.

Mapping of Course Outcomes with Program Outcomes:

CO/PO	PO 1	PO 2	PO 3	PO 4	PO 5	PO 6	PO 7	PO 8
CO1	3	2	2	2	2	1	1	3
CO2	2	3	2	2	2	2	1	2
CO3	2	3	3	2	2	2	1	2
CO4	3	3	3	2	2	2	2	3
CO5	3	2	3	2	3	2	2	3

Mapping of Course Outcomes with Program Specific Outcomes:

CO/PSO	PSO1	PSO2	PSO3
CO1	3	2	1
CO2	2	3	2
CO3	2	3	2
CO4	3	3	3
CO5	3	3	3

UNIT – I

Introduction: Objectives of Taxation - Canons of Taxation - Tax system in India - Direct and Indirect Taxes - Meaning and Types - Powers of Union and States to levy taxes- State Excise-CENVAT. Detail study of State Excise during calculation of Tax.

UNIT – II

Income Tax for Business: Residential status and tax incidence for businesses- Computation of business income- Allowable and disallowable expenses- Depreciation as per Income Tax rules- Tax planning vs. tax evasion for businesses- Set-off and carry forward of business losses- Tax Deducted at Source (TDS) compliance for businesses- Advance tax and self-assessment tax

UNIT – III

Customs Duty: Meaning - Levy and Collection of Customs Duty - Organization of the Customs Department - Officers of the Customs - Powers - Appellate machinery - Infringement of the law - Offences and Penalties - Exemption from Duty - Customs Duty Drawback - Duty Free Zones.

UNIT – IV

GST - Background behind implementing GST - The need for GST- Business impact Benefits of GST- SGST-CGST and IGST - Taxes covered by GST- Definitions - Scope and Coverage Scope of supply-Levy of tax - Rate Structure -Taxable Events.

UNIT – V

GST - Assessment Proceedings - Return - Refunds - Input Tax Credit - Reverse charge Mechanism, Transitional Provisions composition under GST- Administrative structure of GST - Officers as per CGST Act - Officers as per SGST Act - Jurisdiction - Appointment Powers.

Text Books:

1. Spilker, B. C., Ayers, B. C., Barrick, J. A., Lewis, T., Robinson, J. R., & Worsham, R. G. (2022). McGraw Hill's taxation of business entities 2022 edition (13th ed.). McGraw Hill Education. ISBN: 9781264369058
2. Jones, S. M., Callaghan, S. R., & Rhoades-Catanach, S. C. (2021). Principles of taxation for business and investment planning 2021 edition (24th ed.). McGraw Hill Education. ISBN: 9781260247817.

Reference Books:

1. James, M. (2022). The taxation of small businesses 2022/2023 (15th ed.). Spiramus Press. ISBN: 9781913507319.
2. Lederman, L., & Cauble, E. (2025). Understanding corporate taxation (5th ed.). Carolina Academic Press. ISBN: 9781531033095

Web Links:

1. <https://www.youtube.com/watch?v=swrzarYcMvY>
2. https://www.youtube.com/watch?v=QUI_OevD3yw

Relevant cases have to be discussed in each unit and in examination case study is compulsory from any unit.

MAJOR PROGRAM ELECTIVE COURSES
MAJOR 1: FINANCE (FIN)

**INVESTMENT ANALYSIS AND PORTFOLIO
MANAGEMENT**

	L	T	P	C
Course Code: 2508MS51	2	1		3

Course Outcomes:

At the end of the Course, Student will be able to:

- CO1:** Identify the Indian Financial System, investment distinctions, and SEBI's roles.
- CO2:** Analyze risk and return, and evaluate portfolios using the CAPM.
- CO3:** Examine bond valuation and analyze bond management strategies.
- CO4:** Apply equity valuation models and analyze equity using various analytical methods.
- CO5:** Assess mutual fund performance and evaluate using performance models

Mapping of Course Outcomes with Program Outcomes:

CO / PO	PO1	PO2	PO3	PO4	PO5	PO6	PO7	PO8
CO1	3	2	1	2	0	1	2	0
CO2	3	3	0	1	0	2	2	0
CO3	3	2	0	1	0	2	2	0
CO4	3	3	0	2	0	3	2	0
CO5	2	3	0	2	0	2	1	1

Mapping of Course Outcomes with Program Specific Outcomes:

CO / PSO	PSO1	PSO2	PSO3
CO1	3	2	2
CO2	3	3	2
CO3	3	3	2
CO4	3	3	2
CO5	2	3	2

UNIT – I

Introduction to Investment: Introduction, Indian Financial System and Structure, Investment, Speculation and Gambling, Features of Investment, Investment Avenues, Investment Process. The Investment Environment, Securities Market of India, Securities Trading and Settlement, Types of Orders, Margin Trading, Roles and Responsibilities of SEBI.

UNIT – II

Portfolio Analysis: Risk and Return Analysis, Markowitz Portfolio Theory, Mean – Variance Approach, Portfolio Selection, Efficient Portfolios, Single Index Model, Capital Asset Pricing Model, Arbitrage Pricing Theory.

UNIT – III

Bond Valuation: Classification of Fixed Income Securities, Types of Bonds, Interest Rates, Term Structure of Interest Rates, Measuring Bond Yields, Yield to Maturity, Yield to Call, Holding Period Return, Bond Pricing Theorems, Bond Duration, Modified Duration. Active and Passive Bond Management Strategies, Bond immunization, Bond Volatility, Bond Convexity.

UNIT – IV

Equity Valuation: a) Intrinsic Value versus Market Value, Equity Valuation Models- Discounted Cash Flow Techniques, Dividend Discount Models (DDM), Growth Rate cases for DDM, Free Cash Flow Valuation Approaches, Relative Valuation Techniques, Earnings Multiplier Approach, Price/ Earnings, Price/ Book Value, Price/ Sales Ratio, EVA. b) Fundamental Analysis, Technical Analysis, Efficient Market Hypothesis.

UNIT – V

Performance Evaluation: Mutual Funds, Types of Mutual Funds Schemes, Structure, Trends in Indian Mutual Funds, Net Asset Value, Risk and Return, Performance Evaluation Models: Sharpe Model, Treynor Model, Jensen Model, Fama's Decomposition

Text Books:

1. Reilly, F. K., Brown, K. C., & Leeds, S. (2024). Investment analysis and portfolio management (12th ed.). Cengage Learning. ISBN: 9780357988176.
2. Rustagi, R. P. (2021). Investment analysis & portfolio management. Sultan Chand & Sons. ISBN: 9789351611868.

Reference Books:

1. Haghani, V., & White, J. (2023). The missing billionaires: A guide to better financial decisions. Wiley. ISBN: 9781119747918.
2. Verbeek, M. (2021). Panel methods for finance: A guide to panel data econometrics for financial applications. De Gruyter. ISBN: 9783110705390

Web Links:

1. https://onlinecourses.nptel.ac.in/noc21_mg99/preview
2. https://onlinecourses.nptel.ac.in/noc23_mg62/preview

Relevant cases have to be discussed in each unit and in examination case study is compulsory from any unit.

BANKING AND FINANCIAL INSTITUTIONS

	L	T	P	C
Course Code: 2508MS05	2		1	3

Course Outcomes:

At the end of the Course, Student will be able to:

- CO1:** Identify the evolution of banking and role of RBI in the Indian financial system.
- CO2:** Analyze and evaluate the structure and functions of RBI and commercial banks
- CO3:** Apply asset/liability management practices and analyze credit risk management models.
- CO4:** Choose the origin, growth, and lending policies of term lending institutions.
- CO5:** Develop new financial instruments and evaluate SEBI and RBI guidelines.

Mapping of Course Outcomes with Program Outcomes:

CO / PO	PO1	PO2	PO3	PO4	PO5	PO6	PO7	PO8
CO1	3	2	1	2	-	1	2	1
CO2	3	3	1	2	-	1	2	1
CO3	3	3	-	1	-	2	3	1
CO4	2	2	-	2	-	2	2	1
CO5	3	3	1	2	-	3	2	2

Mapping of Course Outcomes with Program Specific Outcomes:

CO / PSO	PSO1	PSO2	PSO3
CO1	3	2	2
CO2	3	3	2
CO3	3	3	3
CO4	2	2	2
CO5	3	3	3

UNIT – I

Financial System in India: Introduction - Evolution of Banking - Phases of development - RBI and the Financial System - Committees on Banking Sector Reforms - Prudential Banking -RBI Guidelines and directions.

UNIT – II

RBI and Commercial Banks: Introduction - Origination, Structure and Functions of RBI and Commercial Banks - Role of RBI and Commercial Banks - Lending and Operation policies - Banks as Intermediaries - NBFCs - Growth of NBFCs - FDI in Banking Sector - Banking Regulations - Law and Practice

UNIT – III

Risk Management in Banks: Introduction - Asset/Liability Management Practices - Credit Risk Management - Credit Risk Models - Country Risk Management - Insurance Regulations and Development Authority (IRDA).

UNIT – IV

Financial Institutions and Development Banking: Introduction - Origin, Growth and Lending Policies of Terms lending Institutions - Working of IDBI - IFCI - STCs - SIDBI - LIC - GIC - UTI - Role of Financial Institutions in Capital Market.

UNIT – V

New Financial Instruments and Institutions: Private Banks - Old generation and new generation private banks - Foreign Banks - NSE - Depositories - DFHI - New Equity and Debt Instruments - SEBI and RBI guidelines.

Text Books:

1. Saunders, A., Cornett, M. M., & Erhemjants, O. (2024). Financial markets and institutions (8th ed.). McGraw Hill Education. ISBN: 9781265068349
2. Choudhry, M. (2022). The principles of banking (2nd ed.). Wiley. ISBN: 9781119755647

Reference Books:

1. Broome, L. L., Markham, J. W., & Gabilondo, J. M. (2022). Regulation of bank financial service activities: Cases and materials (6th ed.). West Academic Publishing. ISBN: 9781647084394.
2. Mishkin, F. S., & Eakins, S. G. (2023). Financial markets and institutions (10th ed.). Pearson. ISBN: 9780138025465

Web Links:

1. <https://archive.nptel.ac.in/courses/110/105/110105121/>
2. https://onlinecourses.nptel.ac.in/noc22_hs72/preview

Relevant cases have to be discussed in each unit and in examination case study is compulsory from any unit.

INTRODUCTION TO FINTECH

	L	T	P	C
Course Code: 2508MS50	2		1	3

Course Outcomes:

At the end of the Course, Student will be able to:

- CO1:** Remember the fundamental concepts of FinTech, its evolution, key drivers, and its impact on various financial sectors.
- CO2:** Understand the different types of digital payment systems, their mechanisms, and regulatory frameworks in digital payments.
- CO3:** Apply blockchain technology and cryptocurrencies in real-world financial applications, including smart contracts and financial inclusion.
- CO4:** Analyze the innovations in InsurTech and WealthTech, and evaluate their impact on the financial industry, including the role of AI and machine learning.
- CO5:** Evaluate emerging FinTech trends, opportunities, challenges, and their potential impact on traditional financial services and global markets.

Mapping of Course Outcomes with Program Outcomes:

CO / PO	PO1	PO2	PO3	PO4	PO5	PO6	PO7	PO8
CO1	2	2	1	2	-	1	2	1
CO2	3	2	1	3	-	1	3	1
CO3	3	3	1	3	-	2	3	2
CO4	3	3	2	3	-	3	3	1
CO5	3	3	2	3	1	3	3	2

Mapping of Course Outcomes with Program Specific Outcomes:

CO / PSO	PSO1	PSO2	PSO3
CO1	2	2	2
CO2	3	3	2
CO3	3	3	3
CO4	3	3	3
CO5	3	3	3

UNIT – I

Introduction to Financial Technologies (FinTech): Definition and scope of FinTech, Historical evolution of FinTech and the role of technology in financial services, Key drivers of the FinTech revolution (regulations, innovations, consumer behavior), Types of FinTech companies and their business models (startups, established companies, tech giants), Global landscape of FinTech and market trends, Key sectors: Payments, Lending, Wealth Management, InsurTech, RegTech, and Blockchain

UNIT – II

Digital Payments & E-Wallets: Overview of digital payment systems: Traditional vs. digital payments, Types of digital payment methods (e.g., mobile wallets, QR codes, P2P payments), Key players in the payment ecosystem (e.g., PayPal, Google Pay, Stripe, Square), Payment gateways and their working mechanism, Security and fraud prevention in digital payments, Rise of contactless payments and mobile banking, Regulatory frameworks for digital payments (e.g., RBI guidelines in India)

UNIT – III

Blockchain & Cryptocurrencies: Introduction to blockchain technology: Definition, working mechanism, and components (blocks, miners, nodes), Applications of blockchain beyond cryptocurrencies: Supply chain, healthcare, voting, etc., Overview of cryptocurrencies: Bitcoin, Ethereum, stablecoins, and altcoins, Understanding cryptocurrency markets and exchanges, Smart contracts and their role in blockchain ecosystems, Regulatory challenges and legal perspectives of cryptocurrencies, Blockchain for financial inclusion

UNIT – IV

InsurTech & WealthTech Innovations: Overview of InsurTech: Disrupting the insurance industry with technology, Types of InsurTech solutions: On-demand insurance, peer-to-peer insurance, data-driven underwriting, WealthTech innovations: Robo-advisors, AI in asset management, digital wealth platforms, Crowdfunding and peer-to-peer lending models, Machine learning and artificial intelligence in personalized wealth management, Regulatory considerations in InsurTech and WealthTech

UNIT – V

The Future of FinTech: Trends, Challenges, and Opportunities: Emerging trends: Artificial intelligence, machine learning, big data, and IoT in FinTech, The role of Open Banking and APIs in the future of FinTech, Challenges: Cybersecurity, data privacy, and regulatory compliance, The impact of FinTech on traditional banking and financial services, FinTech ecosystem in emerging markets, FinTech career opportunities and skills in demand, Case study analysis: Successful FinTech startups and their business models (e.g., Robinhood, Revolut)

Text Books:

1. Kumar, D., & Dhingra, M. (2022). FinTech: Concepts and applications. New Delhi: Sage Publications India. ISBN: 9789354793310
2. Agarwal, R. (2021). Introduction to FinTech: Principles and practices. New Delhi: Taxmann Publications. ISBN: 9789390585950

Reference Books:

1. Gupta, S. (2021). FinTech and digital finance: Transforming the financial landscape. Mumbai: Himalaya Publishing House. ISBN: 9789355431693
2. Mehta, A., & Malik, S. (2022). Emerging trends in FinTech: Technology, regulation and disruption. New Delhi: Bharti Publications. ISBN: 9789392209250

Web Links:

1. <https://www.coursera.org/specializations/wharton-business-financial-modeling>
2. https://onlinecourses.nptel.ac.in/noc21_mg93/preview

Relevant cases have to be discussed in each unit and in examination case study is compulsory from any unit.

**MERGERS, ACQUISITIONS AND CORPORATE
RESTRUCTURING**

	L	T	P	C
Course Code: 2508MS66	2		1	3

Course Outcomes:

At the end of the Course, Student will be able to:

- CO1:** Compare the impact of different types of mergers on stakeholders
- CO2:** Develop strategic M&A decisions using industry life cycle, product life cycle analysis
- CO3:** Construct a comprehensive merger process plan, incorporating target identification
- CO4:** Analyze methods of financing mergers and their implications on capital budgeting decisions
- CO5:** Assess the significance and various forms of corporate restructuring.

Mapping of Course Outcomes with Program Outcomes:

CO / PO	PO1	PO2	PO3	PO4	PO5	PO6	PO7	PO8
CO1	3	3	2	3	1	2	2	2
CO2	3	3	2	3	-	2	3	1
CO3	3	3	1	3	-	2	3	1
CO4	3	2	2	3	-	2	2	1
CO5	2	2	2	3	1	2	2	2

Mapping of Course Outcomes with Program Specific Outcomes:

CO / PSO	PSO1	PSO2	PSO3
CO1	3	3	3
CO2	3	3	3
CO3	3	3	2
CO4	3	3	3
CO5	3	2	3

UNIT – I

Mergers- types of mergers– theories of mergers- operating, financial and managerial synergy of mergers – value creation in horizontal, vertical and conglomerate mergers – internal and external change forces contributing to M & A activities- Impact of M & A on stakeholders.

UNIT – II

M & A – A Strategic Perspective- industry life cycle and product life cycle analysis in M&A decision, strategic approaches to M&A- SWOT analysis, BCG matrix. Takeovers, types, takeover strategies, - Takeover defenses – financial defensive measures – methods of resistance – anti-takeover amendments – poison pills Legal aspects of Mergers/amalgamations and acquisitions/takeovers- Combination and Competition Act- Competition Commission of India (CCI), The SEBI Substantial Acquisition of Shares and Takeover code.

UNIT – III

Merger Process: Dynamics of M&A process - identification of targets – negotiation - closing the deal. Five-stage model – Due diligence– Types - due diligence strategy and process - due diligence challenges. Process of merger integration – organizational and human aspects – managerial challenges of M & A.

UNIT – IV

Methods of Financing Mergers – cash offer, share exchange ratio – mergers as a capital budgeting decision
Synergies from M&A: Operating and Financial synergy Accounting for amalgamation – amalgamation in the nature of merger and amalgamation in the nature of purchase- pooling of interest method, purchase method – procedure laid down under Indian companies act of 2013.

UNIT – V

Corporate Restructuring – significance - forms of restructuring – joint ventures – sell off and spin off – divestitures – equity carve out – leveraged buy outs (LBO) – management buy outs – master limited partnership– Limited Liability Partnership (LLP) in India: Nature and incorporation of LLP-De merger-strategic alliance buyback of shares.

Text Books:

1. Gaughan, P. A. (2021). Mergers, acquisitions, and corporate restructurings (7th ed., Indian adaptation). New Delhi: Wiley India. ISBN: 9788126579902.
2. Sharma, S. K. (2022). Mergers and acquisitions. New Delhi: Sage Publications India. ISBN: 9789354793747.

Reference Books:

1. Godbole, P. (2021). Mergers, acquisitions and corporate restructuring (3rd ed.). New Delhi: Vikas Publishing House. ISBN: 9789354538300
2. Bansal, L. K. (2020). Corporate restructuring: Mergers, acquisitions and other forms. New Delhi: Himalaya Publishing House. ISBN: 9789352628379.

Web Links:

1. <https://nptel.ac.in/courses/110105165>
2. <https://www.coursera.org/specializations/mergersandacquisitions>

Relevant cases have to be discussed in each unit and in examination case study is compulsory from any unit.

FINANCIAL RISK MANAGEMENT AND FINANCIAL DERIVATIVES

	L	T	P	C
Course Code: 2508MS38	2		1	3

Course Outcomes:

At the end of the Course, Student will be able to:

- CO1:** Analyze various types of risks and their measurement, and evaluation.
- CO2:** Apply concepts of Economic Capital and RAROC to measure and manage credit.
- CO3:** Estimate the use of forward and futures contracts.
- CO4:** Explain the mechanics and types of swaps, and assess their application.
- CO5:** Compare and analyze options and their pricing.

Mapping of Course Outcomes with Program Outcomes:

CO / PO	PO1	PO2	PO3	PO4	PO5	PO6	PO7	PO8
CO1	3	3	2	2	-	2	3	1
CO2	3	3	2	3	-	2	3	1
CO3	3	2	2	3	-	1	2	1
CO4	2	2	2	3	-	1	2	1
CO5	3	2	2	3	-	2	2	1

Mapping of Course Outcomes with Program Specific Outcomes:

CO / PSO	PSO1	PSO2	PSO3
CO1	3	3	2
CO2	3	3	3
CO3	3	3	2
CO4	2	3	2
CO5	3	3	2

UNIT – I

Introduction: The concept of Risk- Nature- Need and scope of risk. Source- measurement- identification and evaluation of Risk. Types of risk–Credit, Market, operational risk, Possible Risk events- Risk Indicators. Risk management approaches and methods. Risk reporting process– internal and external.

UNIT – II

Risk Measurement at Corporate Level: Economic capital and RAROC. -Introduction-Meaning of Economic Capital-Probability of Default-Using Risk Adjusted Performance for Business Decisions-Measuring Credit Risk-Measuring Market Risk and measuring operational risk Value at risk (VaR): The concept, Historical Simulation, Monte Carlo simulation, stress testing, back testing

UNIT – III

Forwards: features and pay-off profile of Forward contract. Valuation of forward contracts. Forward Contracts to manage Commodity price risk- Interest rate risk and exchange rate risk. Limitations of Forward contract. **Futures:** Definition. Clearing house- margin requirements- marking to market. Basis and convergence of future price to spot price. Valuation of Futures contract. Differences between forward contracts and futures contracts. Risk management with Futures contracts–hedge ratio and portfolio approach to a risk–minimizing hedge.

UNIT – IV

Swaps: Definition- Introduction to types of swaps like Simple Plain Swaps, Interest rate swaps, currency swaps, and others like Accrediting, Amortizing and Roller Coaster Swaps, Basis Swap, CMT Swaps, Total Return Swaps, Credit Default Swaps. Mechanics of Interest rate Swaps and currency swaps.

UNIT – V

Options: Definition - Types - call option- put option- American option and European option. Options- in the money-at the money and out of the money. Option premium- intrinsic value and time value of options. Pricing of call and put options at expiration and before expiration. Options on stock indices and currencies. Introduction to Greeks, Black & Scholes option pricing model (BSOPM): assumptions.

Text Books:

1. Ghosh, S. (2022). Risk management and financial derivatives (2nd ed.). New Delhi: Cengage Learning India. ISBN: 9789355730079
2. Chance, D. M., & Brooks, R. (2021). An introduction to derivatives and risk management (10th ed., Indian adaptation). Noida: Cengage Learning India. ISBN: 9789387511941.

Reference Books:

1. Kotreshwar, G. (2020). Risk management: Insurance and derivatives (2nd ed.). New Delhi: Himalaya Publishing House. ISBN: 9789352025222
2. Varma, J. R. (2021). Derivatives and risk management. New Delhi: Tata McGraw Hill Education. ISBN: 9789354600533

Web Links:

1. <https://archive.nptel.ac.in/courses/110/107/110107128/>
2. https://onlinecourses.nptel.ac.in/noc22_mg91/preview

Relevant cases have to be discussed in each unit and in examination case study is compulsory from any unit.

INTERNATIONAL FINANCE

	L	T	P	C
Course Code: 2508MS46	2		1	3

Course Outcomes:

At the end of the Course, Student will be able to:

- CO1:** Explain the nature, scope, and challenges of International Financial Management
- CO2:** Analyze the evolution and current structure of the International Monetary System
- CO3:** Identify the function and structure of the foreign exchange market
- CO4:** Apply knowledge of exchange rate movements, government influence, and arbitrage.
- CO5:** Develop strategies for effective asset-liability management, international capital budgeting, and financing, including portfolio and cash management techniques.

Mapping of Course Outcomes with Program Outcomes:

CO / PO	PO1	PO2	PO3	PO4	PO5	PO6	PO7	PO8
CO1	3	2	2	2	-	1	2	1
CO2	3	2	2	2	-	1	2	1
CO3	3	3	2	2	-	1	2	1
CO4	3	3	2	3	-	2	2	1
CO5	3	3	2	3	-	2	3	1

Mapping of Course Outcomes with Program Specific Outcomes:

CO / PSO	PSO1	PSO2	PSO3
CO1	3	2	2
CO2	3	2	2
CO3	3	3	2
CO4	3	3	2
CO5	3	3	3

UNIT – I

Introduction: Nature and Scope of International Financial Management, Domestic FM Vs. IFM, Challenges in International Financial Management. International Flow of Funds: Balance of Payments (BOP), Accounting Components of BOP, Factors affecting International Trade Flows, Agencies that facilitate International Flows. Payment methods of International Trade, Trade Finance Methods, EXIM Bank of India, Amendments in EXIM policy, Regulations and Guidelines.

UNIT – II

International Monetary System: Evolution, Gold Standard, Bretton Woods’s System, the Flexible Exchange Rate Regime, Evaluation of Floating Rates, the Current Exchange Rate arrangements, the Economic and Monetary Union (EMU) and Developments.

UNIT – III

Foreign Exchange Market: Function and Structure of the Forex Markets, Major Participants, Types of Transactions and Settlements Dates, Foreign Exchange Quotations. Process of Arbitrage, Speculation in the Forward Market. Currency Futures and Options Markets, Overview of the other markets, Euro Currency Market, Euro Credit Market, Euro Bond Market, International Stock Market.

UNIT – IV

Exchange Rates: Measuring Exchange Rate Movements, Factors influencing Exchange Rates. Government influence on Exchange Rates, Exchange Rate Systems. Managing Foreign Exchange Risk. International Arbitrage and Interest Rate Parity. Relationship between Inflation, Interest Rates and Exchange Rates, Purchasing Power Parity, International Fisher Effect, Fisher Effect, Interest Rate Parity, Expectations Theory

UNIT – V

Asset–Liability Management: Foreign Direct Investment, International Capital Budgeting, International Capital Structure and Cost of Capital. International Portfolio Management. International Financing: Equity, Bond Financing, Parallel Loans, International Cash Management, Accounts Receivable Management, Inventory Management.

Text Books:

1. Apte, P. G. (2022). International financial management (8th ed.). New Delhi: McGraw Hill Education India. ISBN: 9789354600878
2. Sharan, V. (2021). International financial management (8th ed.). Noida: Pearson Education India. ISBN: 9789353945888

Reference Books:

1. Madura, J. (2021). International financial management (13th Indian ed., adapted by Ashok Banerjee). New Delhi: Cengage Learning India. ISBN: 9789387511897
2. Bhalla, V. K. (2020). International financial management: Text and cases (6th ed.). New Delhi: Anmol Publications. ISBN: 9788126160490

Web Links:

1. https://ugcmoocs.inflibnet.ac.in/index.php/courses/view_pg/733
2. https://onlinecourses.nptel.ac.in/noc23_mg30/preview

Relevant cases have to be discussed in each unit and in examination case study is compulsory from any unit.

BEHAVIORAL FINANCE

	L	T	P	C
Course Code: 2508MS06	2		1	3

Course Outcomes:

At the end of the Course, Student will be able to:

- CO1:** Explain the nature, scope, objectives, and applications of behavioral finance
- CO2:** Analyze Expected Utility Theory and other decision-making theories under risk and uncertainty
- CO3:** Estimate the impact of behavioral factors on financial markets
- CO4:** Apply behavioral factors to corporate finance decisions
- CO5:** Identify the experimental approaches to measure and understand the emotional and neuro physiological mechanisms

Mapping of Course Outcomes with Program Outcomes:

CO / PO	PO1	PO2	PO3	PO4	PO5	PO6	PO7	PO8
CO1	3	2	2	2	-	2	2	1
CO2	3	3	2	2	-	2	2	1
CO3	3	3	2	2	-	3	2	1
CO4	3	2	2	2	1	2	2	1
CO5	2	3	3	2	-	3	2	1

Mapping of Course Outcomes with Program Specific Outcomes:

CO / PSO	PSO1	PSO2	PSO3
CO1	3	2	2
CO2	3	3	2
CO3	3	3	3
CO4	3	3	2
CO5	3	3	3

UNIT – I

Introduction to Behavioral finance: Nature, scope, objectives and application; Investment Decision Cycle: Judgment under Uncertainty :Cognitive information perception - Peculiarities (biases) of quantitative and numerical information perception - Weber law Subjective probability – Representativeness – Anchoring - Asymmetric perception of gains and losses framing and other behavioral effects - Exponential discounting - Human economic behavior - Discount factors for short and long horizons - Experimental measurement of the discount factor - Hyperbolic discounting.

UNIT – II

Utility/ Preference Functions: Expected Utility Theory [EUT] and Rational Thought: Decision making under risk and uncertainty - Expected utility as a basis for decision-making – Theories based on Expected Utility Concept – Decision making in historical prospective - Allais and Elsbeg ‘s Paradoxes - Rationality

from an economics and evolutionary perspective – Herbert Simon and bounded rationality- Investor rationality and market efficiency - Empirical data that questions market efficiency.

UNIT – III

Behavioral Factors and Financial Markets: The Efficient Markets Hypothesis – Fundamental Information and Financial Markets - Information available for Market Participants and Market Efficiency -Market Predictability –The Concept of limits of Arbitrage Model - Asset management and behavioral factors - Active Portfolio Management: return statistics and sources of systematic underperformance. - Fundamental information and technical analysis – the case for psychological influence.

UNIT – IV

Behavioral Corporate Finance: Behavioral factors and Corporate Decisions on Capital Structure and Dividend Policy - Capital Structure dependence on Market Timing - Mergers and Acquisitions. Systematic approach to using behavioral factors in corporate decision making. External Factors and Investor Behavior: Mechanisms of the External Factor influence on risk perception and attitudes - Connection to human psychophysiology and emotional regulation Active portfolio management – the source of the systematic underperformance.

UNIT – V

Emotions and Decision-Making: Experimental measurement of risk-related - Measuring Risk - Emotional mechanisms in modulating risk-taking attitude - Neurophysiology of risk taking. Personality traits and risk attitudes in different domains.

Text Books:

1. Chandra, P. (2021). Behavioral finance (3rd ed.). New Delhi: McGraw Hill Education India. ISBN: 9789354600341
2. Shefrin, H. (2022). Behavioral finance: Psychology, decision-making, and markets (2nd Indian ed.). Noida: Pearson Education India. ISBN: 9789356061516

Reference Books:

1. Baker, H. K., & Ricciardi, V. (2021). Investor behavior: The psychology of financial planning and investing. New Delhi: Wiley India. ISBN: 9781118492987.
2. Rastogi, R. P. (2020). Behavioral finance: Understanding the irrational mind in financial decision making. New Delhi: Sage Publications India. ISBN: 9789353885986.

Web Links:

1. https://onlinecourses.nptel.ac.in/noc23_mg38/preview
2. <https://www.coursera.org/learn/duke-behavioral-finance>

Relevant cases have to be discussed in each unit and in examination case study is compulsory from any unit.

FINANCIAL ANALYTICS

	L	T	P	C
Course Code: 2508MS36	2		1	3

Course Outcomes:

At the end of the Course, Student will be able to:

- CO1:** Identify financial statements to interpret organizational financial health.
- CO2:** Apply time value of money and risk-return measures to make financial decisions.
- CO3:** Analyze investment opportunities using capital budgeting techniques
- CO4:** Assess equity valuations and perform industry, economic, and technical analysis.
- CO5:** Examine bond valuation and immunization strategies to manage fixed-income portfolios effectively.

Mapping of Course Outcomes with Program Outcomes:

CO / PO	PO1	PO2	PO3	PO4	PO5	PO6	PO7	PO8
CO1	3	3	2	2	-	2	2	1
CO2	3	3	3	2	-	2	3	1
CO3	3	3	2	2	-	2	3	1
CO4	3	3	2	3	-	2	3	1
CO5	3	3	2	2	-	2	3	1

Mapping of Course Outcomes with Program Specific Outcomes:

CO / PSO	PSO1	PSO2	PSO3
CO1	3	3	2
CO2	3	3	2
CO3	3	3	2
CO4	3	3	2
CO5	3	3	2

UNIT – I

Techniques of Financial Statement: Horizontal, Vertical Analysis, Trend Analysis, Ratio Analysis, Liquidity, Profitability, Solvency and Turnover Ratio, Valuation of Ratios, Statement of Cash Flow, Classification of Cash Flow, Computing Net Cash Flow: Operating, Investing and Financing Activities. Reporting and Interpretation using Spreadsheet.

UNIT – II

Time Value of Money: Future Value: Simple, Compound Interest and Annuity, Present Value: Discounted, Annuity, Equated Loan Amortization, Perpetuity using Spreadsheets. **Risk and Return:** Holding Period Returns, Arithmetic Mean vs Geometric Mean, Risk: Standard Deviation, Coefficient of Variation, Beta, and Covariance of Stock.

UNIT – III

Capital Budgeting Techniques: Payback Period, Accounting Rate of Return, Net Present Value, Internal Rate of Return, Profitability Index, Decision Tree, Cash Flow in Capital Budgeting, Cost of Capital, Advance Capital Budgeting Techniques, Adjusted Present Value Approach, Competing Project Risk using Spreadsheets.

UNIT – IV

Time series and Trend Analysis: Financial time series data and components (trend, seasonality, volatility)-Moving averages and exponential smoothing-Forecasting techniques: AR, MA, ARIMA (basic concepts)-Use of time series in budgeting, sales, and cash flow forecasting-Visualization of trends using BI tools

UNIT – V

Risk and Scenario Analytics: Types of financial risk: credit, market, liquidity, operational-Risk modeling using historical and simulated data-Sensitivity analysis, scenario analysis, and what-if modeling - Value at Risk (VaR) – basic concept and applications - Use of Monte Carlo simulation for financial risk forecasting

Text Books:

1. Ruparelia, N. B. (2021). Financial analytics: The future of finance (2nd ed.). New Delhi: McGraw Hill Education India. ISBN: 9789354600037.
2. Chandra, P. (2022). Financial management with analytics (10th ed.). New Delhi: Tata McGraw Hill Education. ISBN: 9789355321900.

Reference Books:

1. Rajagopal, S. (2021). Essentials of financial analytics: Tools and techniques. New Delhi: Sage Publications India. ISBN: 9789354791520.
2. Agarwal, V. (2020). Financial analytics for decision making. New Delhi: Vikas Publishing House. ISBN: 9789325986785

Web Links:

1. https://onlinecourses.nptel.ac.in/noc23_mg12/preview
2. <https://www.udemy.com/course/intro-to-business-models-financial-modelling-valuation/>

Relevant cases have to be discussed in each unit and in examination case study is compulsory from any unit.

MAJOR 2: MARKETING (MKTG)

SALES AND RETAIL MANAGEMENT

	L	T	P	C
Course Code: 2508MS74	2		1	3

Course Outcomes:

At the end of the Course, Student will be able to:

- CO1:** Explain the scope and evolution of retail management.
- CO2:** Differentiate between store-based and non-store-based retail formats.
- CO3:** Apply site analysis techniques for selecting retail locations.
- CO4:** Analyze merchandise buying systems and apply market segmentation concepts.
- CO5:** Compare traditional and e-retailing methods and assess the impact of in-store technologies

Mapping of Course Outcomes with Program Outcomes:

CO / PO	PO1	PO2	PO3	PO4	PO5	PO6	PO7	PO8
CO1	3	2	2	2	1	1	2	1
CO2	3	2	2	2	2	1	2	1
CO3	3	3	2	2	1	2	3	2
CO4	3	3	2	3	1	2	3	2
CO5	3	3	2	3	2	2	3	2

Mapping of Course Outcomes with Program Specific Outcomes:

CO / PSO	PSO1	PSO2	PSO3
CO1	3	2	2
CO2	3	2	2
CO3	3	3	2
CO4	3	3	2
CO5	3	3	3

UNIT – I

Introduction - Definition - scope – Characteristics – Evolution – Functions – The retailing process - Managing a retail store / chain - Classification of retail formats - Private label brands or store brands - Retail industry in India - Principles – Retail Sales Goals – Retailing in India – Retailing across the Globe – Global Retailing Trends – Reasons for Retail Growth – Emerging Trends

UNIT – II

Delivering Value Through Retail Formats: Store Based Retail Formats – Retail Sale by Ownership – On the Basis of Merchandise Offered (Food Based Retailer and General Merchandise Retailers). Non– Store Based (Traditional) Retail Mix and Non– Traditional Selling – Traditional Retailing, non – Traditional Retailing and Emerging Retail Formats.

UNIT – III

Deciding Location: Store Location – Introduction – Importance – Target and Store Location – Selection of Loyalty – Site Analysis – Trading Area Analysis – Demand Density – Supply Density – Site Availability – Common Errors – Recent Trends in Store Location. Supply Chain Management – The Supply Chain – Evolution – Why SCM – Innovation in SCM – Hierarchy of Supply Chain Decisions – Warehousing – Major Drivers of Supply Chain – Components of Supply Chain.

UNIT – IV

Retail Buying/Merchandise Buying Systems: Buying systems for staple and fashion merchandise, merchandise budget plan, evaluation of merchandise budget plan, open-to-buy system, allocation of merchandise to stores, analyzing merchandise performance, global sourcing decisions, costs associated with global sourcing, managerial issues, ethical and legal issues, counterfeit merchandise.

Retail Marketing Segmentation: Concept, significance and philosophies of market segmentation, identification of target market, market segmentation process, understanding target market, market demand potential, market supply factors, key retail segments.

UNIT – V

E-Retailing, HRM in Retailing, Category Management, and Pricing Strategy: E-retailing focuses on internet-based retailing, influenced by factors like customer buying behavior, and contrasts with traditional retailing. In-store technologies and the human-tech interface are also important. HRM in retailing involves objectives, job analysis, organizational structure, and setting up a retail organization. Category management optimizes product categories, including store layout and design. Pricing strategies are crucial for retail, covering merchandise pricing, price objectives, and various pricing types to align with business goals.

Text Books:

1. Panda, T. K., Sahadev, S., & Mishra, S. (2021). Sales and distribution management (3rd ed.). New Delhi: Oxford University Press India. ISBN: 9780199492639
2. Berman, B., & Evans, J. R. (2022). Retail management: A strategic approach (13th ed., Indian adaptation by Joel, L.). Noida: Pearson Education India. ISBN: 9789353946198

Reference Books:

1. Sinha, P. K., & Uniyal, D. P. (2020). Managing retailing (3rd ed.). New Delhi: Oxford University Press India. ISBN: 9780199497405
2. Kumar, N. (2021). Sales management: Concepts and cases. New Delhi: Vikas Publishing House. ISBN: 9789325987591

Web Links:

1. https://onlinecourses.nptel.ac.in/noc22_mg51/preview
2. <https://archive.nptel.ac.in/courses/110/105/110105158/>

Relevant cases have to be discussed in each unit and in examination case study is compulsory from any unit.

CONSUMER BEHAVIOR & CUSTOMER RELATIONSHIP MANAGEMENT

	L	T	P	C
Course Code: 2508MS21	2		1	3

Course Outcomes:

At the end of the Course, Student will be able to:

- CO1:** Apply research methods to analyze consumer trends in diverse economic and rural settings.
- CO2:** Compare and contrast various consumer behavior models for strategic application.
- CO3:** Examine CRM strategies and their integration with business operations.
- CO4:** Assess CRM implementation frameworks and barriers.
- CO5:** Analyze the role of call centers and multimedia contact centers in CRM operations.

Mapping of Course Outcomes with Program Outcomes:

CO / PO	PO1	PO2	PO3	PO4	PO5	PO6	PO7	PO8
CO1	3	3	2	2	2	2	2	2
CO2	3	3	2	3	2	2	2	2
CO3	3	2	3	3	2	3	3	2
CO4	3	2	3	2	1	3	3	2
CO5	3	2	2	2	1	3	2	2

Mapping of Course Outcomes with Program Specific Outcomes:

CO / PSO	PSO1	PSO2	PSO3
CO1	3	2	2
CO2	3	3	2
CO3	3	3	3
CO4	3	3	3
CO5	3	2	3

UNIT – I

Understanding Consumer Behavior: Defining Consumer Behavior, need for Consumer Behavior, Understanding Consumer through Research Process, Consumer Behavior in a world of economic instability, Rural Consumer Behavior, Consumer Segmentation, Targeting and Positioning, Segmentation & Branding, Rural Markets.

UNIT – II

Environmental Influences on Consumer Behavior: Influence of Culture, Sub Culture, Social Class, Social Group, Family and Personality, Cross-Cultural Consumer Behavior. Consumer Behavior Models: Advert Sheth Model, EKB Model, Howard Sheth Model, Family Decision-making Model, Pavlovian Model and Economic Model

UNIT – III

Customer Relationship Management Fundamentals: Definition and Significance of Customer Relationship Marketing, Theoretical perspectives of relationship, Evolution of Relationship marketing, Stages of relationship, Issues of relationship, Purpose of relationship marketing, Approach towards marketing: A paradigm shift, Historical Perspectives, CRM Definitions, Emergence of CRM practice, CRM cycle, Significance of CRM, CRM Strategy, Customer Life Time Value, Relationship Life Cycle.

UNIT – IV

Building Customer Relationship Management: Requisites for Effective Customer acquisition, Customer Knowledge Management for Effective CRM, Customer Retention Process, Strategies to Prevent Defection and Recover Lapsed Customers, CRM Implementation: CRM framework for Implementation, Implementing CRM process, Integration of CRM with ERP System, Barriers to effective CRM Gartner ‘s Competency model of CRM.

UNIT – V

Functional Components of CRM: Database Management, Database Construction, Data Warehousing, architecture, Data Mining. Characteristics, Data Mining tools and techniques, Meaning, Significance, Advantages, Call Centre, Multimedia Contact Centre, Important CRM software

Text Books:

1. **Schiffman, L. G., & Wisenblit, J.** (2022). Consumer behavior (12th ed., Indian adaptation by Kumar, S.). Noida: Pearson Education India. ISBN: 9789356061959
2. **Sahay, B. S.** (2021). Customer relationship management (2nd ed.). New Delhi: McGraw Hill Education India. ISBN: 9789354600099

Reference Books:

1. **Majumdar, R.** (2021). Consumer behaviour: Insights from Indian market (2nd ed.). New Delhi: PHI Learning Pvt. Ltd. ISBN: 9789353067091.
2. **Chaturvedi, M.** (2020). Customer relationship management: An Indian perspective. New Delhi: Vikas Publishing House. ISBN: 9789325986723

Web Links:

1. <https://archive.nptel.ac.in/courses/110/105/110105074/>
2. <https://archive.nptel.ac.in/courses/110/105/110105145/>

Relevant cases have to be discussed in each unit and in examination case study is compulsory from any unit.

MARKETING ANALYTICS

	L	T	P	C
Course Code: 2508MS62	2		1	3

Course Outcomes:

At the end of the Course, Student will be able to:

CO1: Explain the Concepts of Marketing Analytics and their relevance in business

CO2: Make use of MS Excel to deal with Marketing Data at basic level

CO3: Appreciate Customer's journey through Product Selection Process and Customer Lifetime Value

CO4: Develop Analysis in Determining the Pricing Strategies

CO5: Analyze the Process of Optimizing Clusters and Measure the Effectiveness of Promotion

Mapping of Course Outcomes with Program Outcomes:

CO / PO	PO1	PO2	PO3	PO4	PO5	PO6	PO7	PO8
CO1	3	3	2	2	2	2	2	2
CO2	3	3	2	2	2	3	3	2
CO3	3	2	3	3	2	2	3	2
CO4	3	2	3	3	2	3	3	2
CO5	3	3	2	3	2	3	3	2

Mapping of Course Outcomes with Program Specific Outcomes:

CO / PSO	PSO1	PSO2	PSO3
CO1	3	2	2
CO2	3	3	2
CO3	3	3	3
CO4	3	3	3
CO5	3	3	3

UNIT – I

Introduction to Marketing Analytics: Definition, Need and Scope of Marketing Analytics, Marketing Analytics Vs Marketing Research, Levels in Marketing Analytics, Adoption and Application of Marketing Analytics, Marketing Analytics and Business Intelligence. MS Excel as a Tool for conduction of Marketing Analytics. Using MS Excel to Organize and Summarize Marketing Data: Creation of Pivot Tables and Organizing Data.

UNIT – II

Summarizing Marketing Data: Summarizing Revenue Data: Month-wise and Product- wise. Slicing & Dicing of Data: Pareto Principle, Report Filters and Slicers. Demographic Analysis: Analyzing Sales Data by Age, Gender, Income and Location, Construction of Crosstabs of Two Demographic Variables. Using GETPIVOT Function for Pulling Data. Adding Data Labels and Data Tables.

UNIT – III

Customer Analytics: Customer Journey Mapping and the Process of Mapping (How to). Metrics for Tracking Customer Experience: Customer Feedback Metrics & Behaviour Derived Customer Metrics. Customer Persona, Building a Customer Persona and its Benefits, Parts of Buyer Persona. What Customer Wants: Using Conjoint Analysis for Levels in Consumer Decision Process in Product Choices and Product Attributes. Customer Lifetime Value (CLV). Calculating Customer Lifetime Value: Creating the Basic Customer Value Template, Measuring Sensitivity Analysis with Two-Way Tables, Estimating the Chance if Customer is still Active.

UNIT – IV

Pricing Analytics: Pricing, Goals of Pricing, Price Elasticity, Estimating Linear and Power Demand Curves, Using Excel Solver to Optimize Price, Incorporating Complementary Products, Using Solver Table to Price Multiple Products and Finding Demand Curve for All Products. Price Bundling, Bundling Prices to Extract Consumer Surplus, Mixed Bundling, Using Evolutionary Solver to Find Optimal Bundle Prices. Price Skimming.

UNIT – V

Segmentation & Promotion Analytics: Segmentation uses Cluster Analysis, Conjoint Analysis, and Decision Trees. Promotion Analytics covers different promotions, discounting, and measuring ad effectiveness via the Adstock Model. Media models include Linear Allocation, Quantity Discounts, and Monte Carlo Simulation, with Pay-per-click advertising.

Text Books:

1. Davenport, T., & Harris, J. (2022). Competing on analytics: The new science of winning (2nd Indian ed.). Noida: Pearson Education India. ISBN: 9789355305441
2. Sharma, A., & Sharma, S. (2021). Marketing analytics: Data-driven techniques with Excel (2nd ed.). New Delhi: McGraw Hill Education India. ISBN: 9789354657818

Reference Books:

1. Kumar, V. (2021). Marketing analytics: Strategic models and metrics. New Delhi: Vikas Publishing House. ISBN: 9789325985436.
2. Tripathi, P. (2020). Marketing analytics and customer insights. New Delhi: Sage Publications India. ISBN: 9789353888047

Web Links:

1. https://onlinecourses.nptel.ac.in/noc20_mg30/preview
2. <https://archive.nptel.ac.in/courses/110/105/110105142/>

Relevant cases have to be discussed in each unit and in examination case study is compulsory from any unit.

STRATEGIC MARKETING MANAGEMENT

	L	T	P	C
Course Code: 2508MS81	2		1	3

Course Outcomes:

At the end of the Course, Student will be able to:

- CO1:** Explain the concepts of vision, mission, objectives, and goals in relation to marketing strategies
- CO2:** Estimate the need for and forms of corporate restructuring.
- CO2:** Interpret marketing strategies across FMCG, industrial, and services sectors, and analyze constraints in effective marketing strategy implementation
- CO2:** Develop marketing audits to assess strategic effectiveness and measure marketing performance
- CO2:** Develop marketing audits to assess strategic effectiveness and measure marketing performance

Mapping of Course Outcomes with Program Outcomes:

CO / PO	PO1	PO2	PO3	PO4	PO5	PO6	PO7	PO8
CO1	3	2	3	2	3	2	2	3
CO2	3	3	2	2	2	3	2	2
CO3	3	3	3	3	3	3	3	2
CO4	3	3	3	2	2	3	2	3
CO5	3	2	2	3	3	3	2	3

Mapping of Course Outcomes with Program Specific Outcomes:

CO / PSO	PSO1	PSO2	PSO3
CO1	3	3	2
CO2	3	2	2
CO3	3	3	3
CO4	3	3	3
CO5	3	3	3

UNIT – I

Introduction to Strategic Marketing Management: Strategic marketing process. Concept of strategic marketing. Levels of Strategies-Corporate, Business and Operational level. Strategy Formulation – Vision, Mission, Objectives and Goals of business and their relationship with Strategic Marketing Management. Considerations for formulation of marketing strategies for all components of Product, Price, Promotion and Distribution.

UNIT – II

Corporate Restructuring and Strategy Evaluation: Introduction to corporate restructuring, need for corporate restructuring and its forms. Evaluation of strategic alternatives, types of strategic alternatives like portfolio analysis and its techniques. Model as basic foundation of Strategic Marketing - McKinsey's 7s framework for analyzing and improving organizational effectiveness.

UNIT – III

Marketing Strategy Implementation: Integration of Marketing Strategies and their application to different business sectors – FMCG, Industrial, & Services. Constraints in marketing strategy implementation.

UNIT – IV

Marketing Strategy Evaluation: Marketing Audits & their scope – Measurement of Marketing Performance and its feedback to next year 's Marketing strategy formulation. Economic losses due to disasters-Issues and Strategies for preventing disasters and preparedness measures.

UNIT – V

Recent Trends in Strategic Marketing Management - Eco-friendly strategies. Growing need of public private partnership. Corporate Social Responsibility (CSR), strategies of linking CSR with profit and sustainability.

Text Books:

1. Kotler, P., Keller, K. L., & Jha, M. (2021). Marketing management: A south Asian perspective (16th ed.). New Delhi: Pearson Education India. ISBN: 9789332585257
2. Venkatesh, S. (2022). Strategic marketing management: Concepts and cases. New Delhi: McGraw Hill Education India. ISBN: 9789355968127

Reference Books:

1. Kumar, R. (2021). Strategic marketing management: Text and cases. New Delhi: Vikas Publishing House. ISBN: 9789325984576
2. Saxena, R. (2020). Marketing management (6th ed.). New Delhi: Tata McGraw Hill Education. ISBN: 9789352602323

Web Links:

1. <https://archive.nptel.ac.in/courses/110/104/110104055/>
2. <https://nptel.ac.in/courses/110104055>

Relevant cases have to be discussed in each unit and in examination case study is compulsory from any unit.

DIGITAL & SOCIAL MEDIA MARKETING

	L	T	P	C
Course Code: 2508MS29	2		1	3

Course Outcomes:

At the end of the Course, Student will be able to:

- CO1:** Explain the concept, scope, and benefits of digital marketing and compare digital marketing with traditional marketing
- CO2:** Compare various digital marketing channels including website marketing, search engine marketing, social media marketing, and mobile marketing
- CO3:** Develop a digital marketing plan including situational analysis, goals, objectives, marketing strategy, action plan, and budget
- CO4:** Analyze the importance of SEM and online advertising and compare payment methods in online advertising
- CO5:** Assess the role of social media platforms like Facebook, LinkedIn, and Twitter in customer reach and retention.

Mapping of Course Outcomes with Program Outcomes:

CO / PO	PO1	PO2	PO3	PO4	PO5	PO6	PO7	PO8
CO1	3	3	2	2	2	3	3	2
CO2	3	3	3	2	2	3	2	2
CO3	3	3	3	3	2	3	3	3
CO4	3	3	3	3	3	3	3	3
CO5	3	3	2	3	3	3	3	3

Mapping of Course Outcomes with Program Specific Outcomes:

CO / PSO	PSO1	PSO2	PSO3
CO1	3	3	2
CO2	3	3	2
CO3	3	3	3
CO4	3	3	3
CO5	3	3	3

UNIT – I

Understanding Digital Marketing: Concept, Need and Scope of Digital Marketing, Comparison of Marketing and Digital Marketing, Components of Digital Marketing, Benefits of Digital Marketing, Digital Marketing Platforms and Strategies, Digital Marketing Trends.

UNIT – II

Channels of Digital Marketing: Includes Website Marketing, SEO, Online Ads, Email, Blog, Social Media, Audio/Video Marketing, PR, Mobile Marketing, and the shift from traditional to digital channels. Marketing in the Digital Era: Focuses on audience segmentation, digital media use across segments, organizational and purchasing characteristics, and using digital media for customer reach, acquisition, retention, and loyalty.

UNIT – III

Digital Marketing Plan: Need of a Digital Marketing Plan, Elements of a Digital Marketing Plan: Marketing Plan, Executive Summary, Mission, Situational Analysis. Opportunities and Issues, Goals and Objectives, Marketing Strategy, Action Plan, Budget, Writing the Marketing Plan and Implementing the Plan.

UNIT – IV

Search Engine Marketing (SEM) and Online Advertising: Importance of SEM, Understanding Web Search: Key Words, HTML Tags, Inbound Links. Online Advertising vs. Traditional Advertising. Payment Methods of Online Advertising: CPM (Cost-per-Thousand) and CPC (Cost-per click). Display of Ads: Choosing a Display Ad Format, Landing Page and its Importance.

UNIT – V

Social Media Marketing: Understanding social media, Social Networking with Face book, LinkedIn, Blogging as a Social Medium, Micro blogging with Twitter, Social Sharing with YouTube and social media for Customer Reach, Acquisition and Retention. Measurement of Digital Media: Analyzing Digital Media Performance, Analyzing Website Performance, Analyzing Advertising Performance.

Text Books:

1. Chaffey, D., & Ellis-Chadwick, F. (2022). Digital marketing (8th ed.). New Delhi: Pearson Education India. ISBN: 9789355407806.
2. Singh, S., & Kumar, R. (2021). Social media marketing: Principles and strategies. New Delhi: McGraw Hill Education India. ISBN: 9789354658648.

Reference Books:

1. Gupta, S., & Arora, N. (2021). Digital marketing essentials. New Delhi: Vikas Publishing House. ISBN: 9789325984255.
2. Sinha, A. K. (2020). Social media marketing strategies. New Delhi: Sage Publications India. ISBN: 9789353889471

Web Links:

1. https://onlinecourses.nptel.ac.in/noc22_mg109/preview
2. https://onlinecourses.swayam2.ac.in/ugc19_hs26/preview

Relevant cases have to be discussed in each unit and in examination case study is compulsory from any unit.

SERVICES MARKETING

Course Code: 2508MS76

L	T	P	C
2		1	3

Course Outcomes:

At the end of the Course, Student will be able to:

- CO1:** Explain the concepts of services and service marketing.
- CO2:** Identify and explain the key characteristics of services and differentiate the Segmentation, Targeting, Positioning process in services.
- CO3:** Estimate service quality management using models like SERVQUAL and the gap model
- CO4:** Analyze strategies to address the challenges of intangibility, inconsistency, and inseparability of services.
- CO5:** **CO5:** Assess current trends and innovations in services marketing including e-commerce, e-CRM, self-service technologies, and marketing strategies for diverse service categories.

Mapping of Course Outcomes with Program Outcomes:

CO / PO	PO1	PO2	PO3	PO4	PO5	PO6	PO7	PO8
CO1	3	2	2	3	3	2	3	2
CO2	3	3	3	2	3	2	3	2
CO3	3	3	3	3	3	2	3	3
CO4	3	3	3	3	3	3	3	3
CO5	3	3	3	2	3	3	3	3

Mapping of Course Outcomes with Program Specific Outcomes:

CO / PSO	PSO1	PSO2	PSO3
CO1	3	3	2
CO2	3	3	2
CO3	3	3	3
CO4	3	3	3
CO5	3	3	3

UNIT – I

Understanding Services: Introduction - meaning of service concepts, nature and scope of services, marketing of services versus physical goods, growth of services sector in India, Classification of services. Customer involvement in service process and managing service encounters

UNIT – II

Services Marketing: The distinguishing key characteristics of services, Consumer behaviour in services. Services marketing mix - Product, Pricing, Place, Promotion, People, Physical Evidence and Process. - Service triangle - Segmenting, Targeting and positioning for services marketing.

UNIT – III

Role of Quality in Service – Service Quality management, Dimensions of service quality, – gap model - SERVQUAL – demand management services strategies– service blue printing - Service failures and Recovery strategies, etc.

UNIT – IV

Overview of Strategies for Services marketing - strategies to deal with intangibility, inventory inconsistency and inseparability of Services - basic service package – new service development stages. Pricing objectives and strategies – service distribution

UNIT – V

Contemporary Issues in Service Marketing - Current trends in services marketing. Ecommerce and e-marketing – e-CRM - Innovations in services marketing- self-service technologies - Marketing of varied services.

Text Books:

1. Zeithaml, V. A., Bitner, M. J., & Gremler, D. D. (2021). Services marketing: Integrating customer focus across the firm (8th Indian ed.). New Delhi: McGraw Hill Education India. ISBN: 9789354866452
2. Ramaswamy, V. S., & Namakumari, S. (2021). Marketing management: Services marketing (5th ed.). New Delhi: Macmillan India. ISBN: 9789390307868.

Reference Books:

1. Kumar, R., & Rajan, C. A. (2022). Services marketing: Concepts and cases. New Delhi: Vikas Publishing House. ISBN: 9789325986297
2. Pal, P. (2020). Services marketing: Text and cases. New Delhi: Sage Publications India. ISBN: 9789353888757

Web Links:

1. <https://archive.nptel.ac.in/courses/110/105/110105078/>
2. https://onlinecourses.nptel.ac.in/noc20_mg12/preview

Relevant cases have to be discussed in each unit and in examination case study is compulsory from any unit.

MARKETING RESEARCH

	L	T	P	C
Course Code: 2508MS65	2		1	3

Course Outcomes:

At the end of the Course, Student will be able to:

- CO1:** Explain the entry and editing of marketing research data.
- CO2:** Develop the marketing research design and develop a marketing research proposal
- CO3:** Identify the sample design for the marketing research.
- CO4:** Examine the measurement scales and questionnaire design.
- CO5:** Analyze hypothesis testing and data presentation.

Mapping of Course Outcomes with Program Outcomes:

CO / PO	PO1	PO2	PO3	PO4	PO5	PO6	PO7	PO8
CO1	3	2	3	2	2	2	3	2
CO2	3	3	3	2	2	2	3	3
CO3	3	3	3	2	2	3	3	2
CO4	3	3	3	3	3	3	3	3
CO5	3	3	3	3	3	3	3	3

Mapping of Course Outcomes with Program Specific Outcomes:

CO / PSO	PSO1	PSO2	PSO3
CO1	3	2	2
CO2	3	3	2
CO3	3	3	3
CO4	3	3	3
CO5	3	3	3

UNIT – I

Introducing Spreadsheet: Choosing the correct tool; Creating and Saving; Spreadsheet workspace; Managing the workspace; Entering and editing data; Data entry; Selecting cells; Saving time when entering data. Presenting a spreadsheet; Number and date/time format tools; Percentages; Dates and Times; Currency; Text; Performing calculations; Basic arithmetic; Using functions; Replicating formulae; Absolute cell addressing; References between worksheets.

UNIT – II

Marketing Research Design: The Process of Defining the Problem and Developing an Approach, Defining a Marketing Research Problem, Exploratory, Descriptive, Casual Research Design and Marketing Research Proposal.

UNIT – III

Sampling and Data Collection: Sampling Design Process, Classification of Sampling Techniques, Probability and Non-Probability Sampling Techniques, Internet Sampling, Sampling Distribution, Sample Size Determination, Non-Response Issues in Sampling. Sources of Data Collection, Methods of Data Collection.

UNIT – IV

Measurement and Scaling: Concept of Measurement, Types of Measurement Scales: Likert, Semantic Differential, Guttman, Interval, Q-Sort, Nature of Measurement, Characteristics of a Good Measurement, Nature of Attitude Scale, Rating Scale, Ranking Scale, Questionnaire Design, Editing, Coding and Tabulation of data.

UNIT – V

Analysis and Presentation of Data: Data Preparation, Data Preparation Process, Statistically Adjusting Data, Frequency Distribution, Cross Tabulation, Hypothesis Testing, Bi-Variate Analysis, Correlation, Regression, Multi-Variate Analysis, Discriminant, Logit Analysis, Factor Analysis, Cluster Analysis. Report Writing, Report Preparation and Presentation.

Text Books:

1. Naresh K. Malhotra (2021). Marketing research: An applied orientation (8th ed.). Noida: Pearson Education India. ISBN: 9789354340918
2. Kumar, V. (2022). Marketing research (3rd ed.). New Delhi: Oxford University Press India. ISBN: 9780199498853.

Reference Books:

1. Kothari, C. R., & Garg, G. (2021). Research methodology: Methods and techniques (4th ed.). New Delhi: New Age International Publishers. ISBN: 9789355349749.
2. Srivastava, R. K., & Rego, L. L. (2020). Marketing research: Text and cases (2nd ed.). New Delhi: Tata McGraw Hill Education. ISBN: 9789390390857

Web Links:

1. <https://archive.nptel.ac.in/courses/110/107/110107080/>
2. https://onlinecourses.nptel.ac.in/noc20_mg49/preview

Relevant cases have to be discussed in each unit and in examination case study is compulsory from any unit.

BRAND MANAGEMENT

	L	T	P	C
Course Code: 2508MS10	2		1	3

Course Outcomes:

At the end of the Course, Student will be able to:

- CO1:** Explain the basic concepts of branding,
- CO2:** Analyze brand-related terms and brand positioning
- CO3:** Build brand equity through strategic marketing, brand value, planning and potential
- CO4:** Develop and manage brand portfolios, architecture models, and addressing challenges.
- CO5:** Identify extensions' pros and cons, leveraging various secondary brand associations effectively.

Mapping of Course Outcomes with Program Outcomes:

CO / PO	PO1	PO2	PO3	PO4	PO5	PO6	PO7	PO8
CO1	3	2	3	2	2	2	3	2
CO2	3	3	3	2	2	2	3	3
CO3	3	3	3	3	3	3	3	2
CO4	3	3	3	3	3	3	3	3
CO5	3	3	3	3	3	3	3	3

Mapping of Course Outcomes with Program Specific Outcomes:

CO / PSO	PSO1	PSO2	PSO3
CO1	3	2	2
CO2	3	3	2
CO3	3	3	3
CO4	3	3	3
CO5	3	3	3

UNIT – I

Branding Concepts: Introduction to Brand, Brand and Branding Basics, Relationship of Brands with Customers, Building Successful Brands. Benefits of branding, Inputs for branding, Model (David Aker's) to develop brand strategy, Brand management process.

UNIT – II

Terms Associated with Brands: Understanding Various Terms, Brand Names and Brand Extensions, Co-Branding and Corporate Branding, Brand Associations and Brand Image. Brand Positioning: Definition and importance of positioning. Positioning Strategy: Target market, defining competition, updating positioning overtime.

UNIT – III

Brand Equity: Meaning, Relevance of brand equity to business, Brand elements to build brand equity. Designing marketing programme (Product, Price, Distribution channel and IMC strategy) to build brand equity. Brand Processing Brand Evolution: Value of Brand, Brand Planning and Brand Potential.

UNIT – IV

Brand Portfolio: Meaning and Objectives of portfolio, Developing portfolio, Challenges in brand portfolio management. Brand Architecture: Models of brand architecture, Developing brand architecture, Indicators of brand architecture issues.

UNIT – V

Product and Brand Extensions: Advantages of Extensions, Disadvantages of Brand Extensions, Brand Extension Guidelines. Leveraging Secondary Brand Associations: Company, Country of origin, Channels of Distribution, Co-Branding, Licensing, Celebrity Endorsement and Events.

Text Books:

1. Keller, K. L., & Swaminathan, V. (2021). Strategic brand management: Building, measuring, and managing brand equity (5th ed.). Noida: Pearson Education India. ISBN: 9789332587220
2. Sharma, A. (2022). Brand management: Concepts and practices. New Delhi: McGraw Hill Education India. ISBN: 9789355968998.

Reference Books:

1. Kumar, R. (2021). Brand management: A contemporary perspective. New Delhi: Vikas Publishing House. ISBN: 9789325984170
2. Rajagopal, A. (2020). Branding and brand management. Chennai: PHI Learning Private Limited. ISBN: 9789389854225

Web Links:

1. https://onlinecourses.nptel.ac.in/noc23_mg117/preview
2. <https://archive.nptel.ac.in/courses/110/107/110107161/>

Relevant cases have to be discussed in each unit and in examination case study is compulsory from any unit.

**MAJOR 3: HUMAN RESOURCE (HR)
PERFORMANCE MANAGEMENT**

	L	T	P	C
Course Code: 2508MS71	2		1	3

Course Outcomes:

At the end of the Course, Student will be able to

- CO1:** Explain the key concepts of Performance Management.
- CO2:** Identify the process of Performance Management by comparing with Human Resource Management.
- CO3:** Examine the planning and process of Performance Analysis.
- CO4:** Develop the process of Performance Review Discussions and Ratings.
- CO5:** Implement Performance Management System to selected Organizations.

Mapping of Course Outcomes with Program Outcomes:

CO / PO	PO1	PO2	PO3	PO4	PO5	PO6	PO7	PO8
CO1	3	2	3	2	2	2	3	2
CO2	3	3	3	2	3	3	3	3
CO3	3	3	3	3	3	3	3	2
CO4	3	3	3	3	3	3	3	3
CO5	3	3	3	3	3	3	3	3

Mapping of Course Outcomes with Program Specific Outcomes:

CO / PSO	PSO1	PSO2	PSO3
CO1	3	2	2
CO2	3	3	3
CO3	3	3	3
CO4	3	3	3
CO5	3	3	3

UNIT – I

Introduction to Performance Management: Definition of Performance Management, Evolution Performance Management, Definitions and Differentiation of Terms Related to Performance Management. Role, Importance and Dimensions of Performance Management in organization Linkage of Performance Management to Other HR Processes, Performance Management in today scenario.

UNIT – II

Performance Management Process: Relevance of objectives in organizations and Performance Management, organizational and Individual performance in Performance Management, process Performance Management, Performance Management and Human Resource Management.

UNIT – III

Performance Planning and Analysis: Concept of Performance Planning, Performance Planning a Performance Analysis, KPAs and Performance Planning, Components of Performance Plannin Objectives of Performance Analysis, Performance Analysis Process.

UNIT – IV

Performance Review and Discussion: Significance of Performance Review in Performance Management, Process of Performance Review, Performance Ratings: Factors affecting appraisal Methods and Errors, Reducing Rater Biases. Performance Review Discussions: Objectives, Requisites, Process, Role of Mentoring and Coaching in Performance Review Discussions.

UNIT – V

Implementing Performance Management System: Operationalizing change through Performance Management Process, Factors affecting Implementation, Pitfalls of Implementation, Experiences in Performance Management: Traditional Practices in the Industry, Recent approaches in practice, Case studies of Performance Management Systems in selected organizations

Text Books:

1. Aguinis, H. (2022). Performance management (5th ed.). Noida: Pearson Education India. ISBN: 9789356061776
2. Bhattacharyya, D. K. (2021). Performance management systems and strategies (2nd ed.). New Delhi: Pearson Education India. ISBN: 9789353439844

Reference Books:

1. Sarma, A. M. (2021). Performance management systems. Mumbai: Himalaya Publishing House. ISBN: 9789354942077
2. Bhatia, S. K. (2020). Performance management: Systems, practices, and strategies. New Delhi: Deep & Deep Publications. ISBN: 9788176299790

Web Links:

1. <https://archive.nptel.ac.in/courses/110/105/110105137/>
2. <http://digimat.in/nptel/courses/video/110105137/L03.html>

Relevant cases have to be discussed in each unit and in examination case study is compulsory from any unit.

INTERNATIONAL HUMAN RESOURCE MANAGEMENT

	L	T	P	C
Course Code: 2508MS47	2		1	3

Course Outcomes:

At the end of the Course, Student will be able to:

- CO1:** Explain the concepts of International HRM by comparing with Domestic HRM.
- CO2:** Identify and manage various assignments in international context.
- CO3:** Demonstrate Cross Culture Communication and Negotiation
- CO4:** Analyze different Approaches of Compensation in Global Assignments
- CO5:** Apply the IHRD concepts through Global strategic advancements.

Mapping of Course Outcomes with Program Outcomes:

CO / PO	PO1	PO2	PO3	PO4	PO5	PO6	PO7	PO8
CO1	3	2	3	2	2	2	3	2
CO2	3	3	3	2	3	3	3	3
CO3	3	3	3	3	3	3	3	2
CO4	3	3	3	3	3	3	3	3
CO5	3	3	3	3	3	3	3	3

Mapping of Course Outcomes with Program Specific Outcomes:

CO / PSO	PSO1	PSO2	PSO3
CO1	3	2	2
CO2	3	3	3
CO3	3	3	3
CO4	3	3	3
CO5	3	3	3

UNIT – I

Introduction: Introduction to International HRM, A Global HR Perspective in New Economy, HR Challenges at International Level, Implications of Managing People and Leveraging Human Resource, Strategic Role of International HRM, Distinction between Domestic and International HRM, PCNs, TCNs, HCNs.

UNIT – II

Managing International Assignments: Significance, International HR Planning, Recruitment and Selection sources, Staffing policy, Training and Management Development in Multinational Companies, Cross Cultural Training, Performance Management, International Performance Appraisal, International assignments for Women, Problems.

UNIT – III

Cross Cultural Management: Concept, Importance and issues, Theories, Cross Culture Communication and Negotiation, Cross Culture Teams, Talent Crunch, Indian MNCs and Challenges, International Labour Relations, Industrial Democracy, Repatriation Process, Challenges, Repatriation Programme, Managing Expatriates and Causes of Expatriate Failure.

UNIT – IV

Compensation Management: Concept, Objectives, Importance, Trends, Issues, Methods, Factors of Consideration, Different Approaches of Compensation in Global Assignments, Global Compensation Implications on Indian systems, Compensation and Benefits for International Assignees.

UNIT – V

Global Strategic Advantages Through HRD: Measures for creating global HRD Climate – Strategic Framework of HRD and Challenges - Globalization and Quality of Working Life and Productivity – Challenges in Creation of New Jobs through Globalization, New Corporate Culture.

Text Books:

1. Dowling, P. J., Festing, M., & Engle, A. D. (2021). International Human Resource Management (8th ed.). Cengage India, ISBN: 9789386668585
2. Harzing, A.-W., & Pinnington, A. H. (2021). International Human Resource Management (5th ed.). Sage Publications India, ISBN: 9789386062895

Reference Books:

1. Reiche, B. S., Tenzer, H., & Harzing, A.-W. (2022). International Human Resource Management (6th ed.). Sage Publications Ltd, ISBN: 9781529763751
2. Caligiuri, P. (2021). Build Your Cultural Agility: The Nine Competencies of Successful Global Professionals. HarperCollins Leadership, ISBN: 9781400219609.

Web Links:

1. <https://www.youtube.com/watch?v=7ea8l0vM0OU>
2. <https://www.youtube.com/watch?v=bxkgpfh58rU>

Relevant cases have to be discussed in each unit and in examination case study is compulsory from any unit.

HR ANALYTICS

	L	T	P	C
Course Code: 2508MS40	2		1	3

Course Outcomes:

At the end of the Course, Student will be able to:

- CO1:** Gain an understanding of the relevance of HR Analytics in the current scenario.
- CO2:** Develop an understanding of the models of conducting HR Analytics
- CO3:** Use MS Excel for conduction of HR Analytics for key HR Processes
- CO4:** Compare various tools and software technologies used for conduction of descriptive HR Analytics and Visualization of HR Data.
- CO5:** Appreciate the significance of Predictive and Prescriptive Analytics.

Mapping of Course Outcomes with Program Outcomes:

CO / PO	PO1	PO2	PO3	PO4	PO5	PO6	PO7	PO8
CO1	3	3	3	2	3	3	3	3
CO2	3	3	3	3	3	3	3	3
CO3	3	2	3	2	3	3	3	2
CO4	3	3	3	3	3	3	3	2
CO5	3	3	3	3	3	3	3	3

Mapping of Course Outcomes with Program Specific Outcomes:

CO / PSO	PSO1	PSO2	PSO3
CO1	3	3	2
CO2	3	3	3
CO3	3	3	3
CO4	3	3	3
CO5	3	3	3

UNIT – I

Introduction to HR Analytics: History of Different HRM Perspectives, Transition from HRM to HCM and Gaining Sustainable Advantage through HCM. HR Analytics and Changing Role of HR Professionals. Importance, Scope and Benefits of HR Analytics. Levels of Analysis and Conducting analytics. Key Influencers of HR Analytics Process. Big Data Era in HR Analytics, HR Analytics – Linkage to Business Outcomes.

UNIT – II

Understanding HR Analytics: Conducting HR Analytics: Models of HR Analytics, How to Conduct HR Analytics. Understanding HR Data: Importance of Data, Types and Scales of Data, Methods of Capturing Data, Data Examination & Purification. Understanding various HR Metrics from the perspective of HR Analytics.

UNIT – III

Analytics for Key HR Processes Using MS Excel: HR Analytics for Recruitment & Selection, Training & Development, Performance Appraisal, Talent Management, Employee Engagement, Compensation Management – Bench marking- revolt forecasting and Expatriate Management.

UNIT – IV

Descriptive Analytics: Overview of Select Tools for Conduction HR Analytics: MS Excel, Power BI, Python, SPSS. Descriptive Analytics in HR: HR Dashboards using MS Excel, Slicing and Dicing of HR Data using MS Excel Pivot Table Applications, Data Visualization for Key HR processes.

UNIT – V

Predictive & Prescriptive HR Analytics: Predictive HR Analytics: Correlation, Linear and Multiple Regression, Factor Analysis and Cluster Analysis, Comparison of Means and Analysis of Variance for Manpower Demographics, Employee Satisfaction, And Training Effectiveness etc. Prescriptive HR Analytics, Predictive vs Prescriptive HR Analytics, Future of HR Analytics.

Text Books:

1. Dhir, S., & Pal, S. (2021). Human Resource Analytics: Theory and Application Techniques. Cengage Learning India, ISBN: 9789353505295.
2. Uppal, N. (2020). HR Analytics: Strategic Decision Making. Pearson Education India, ISBN: 9789390168408.

Reference Books:

1. Tripathi, S. S., & Ray, R. (2022). HR Analytics In-Depth. BPB Publications, ISBN: 9789355512079.
2. Kumar, P., Rao, S. K., & Nayana, N. (2021). Fundamentals of HR Analytics. IIP Publications, ISBN: 9781956102840

Web Links:

1. https://onlinecourses.nptel.ac.in/noc24_hs126/preview
2. <https://www.coursera.org/learn/human-resources-analytics>

Relevant cases have to be discussed in each unit and in examination case study is compulsory from any unit.

ORGANIZATION CHANGE AND DEVELOPMENT

	L	T	P	C
Course Code: 2508MS70	2		1	3

Course Outcomes:

At the end of the Course, Student will be able to:

- CO1:** Explain the concepts, types, and models of organizational change.
- CO2:** Identify reasons for resistance to change.
- CO3:** Explain the history, process, and key components of OD.
- CO4:** Develop appropriate intervention strategies for specific organizational contexts.
- CO5:** Analyze different perspectives and concepts of learning organizations, knowledge management, and work culture.

Mapping of Course Outcomes with Program Outcomes:

CO / PO	PO1	PO2	PO3	PO4	PO5	PO6	PO7	PO8
CO1	3	2	3	2	3	3	3	2
CO2	2	3	3	3	3	2	3	3
CO3	3	3	3	2	3	3	2	3
CO4	3	3	3	3	3	3	3	2
CO5	3	3	3	3	3	3	3	3

Mapping of Course Outcomes with Program Specific Outcomes:

CO / PSO	PSO1	PSO2	PSO3
CO1	3	2	2
CO2	3	3	3
CO3	3	3	3
CO4	3	3	3
CO5	3	3	3

UNIT – I

Organizational Change: Introduction, Meaning, Nature and Types of Change, Models of Change - Lewis's Force field, Systems Model, Action research model, organizational vision and strategic planning, Dynamics of planned change, Change and its Impact.

UNIT – II

Resistance to Change: Reasons for the resistance, overcoming resistance for the change, Systematic approach to make change, Factors for effective change, Strategies and Skills of leaders for Communicating Change, Designing the change, Implementing Change, Consolidating Change.

UNIT – III

Organization Development (OD): Introduction to Organization Development, History of OD, evolution of OD, Process of OD, Challenges to OD, entering into OD relationship, developing a contract, **Diagnosing Organizations**, Diagnostic Strategies and Skills, Power, Politics and Ethics in OD, Evaluating change and future of Organizational Development, OD Change Agents.

UNIT-IV

Organization Development Interventions: Definition, Types and Process of OD Intervention, Results of OD, Actors to be considered, Choosing and sequencing intervention activities, Typology of interventions based on target groups, Human Process interventions, Structural and Miscellaneous OD Interventions, IT and OD, TQM and OD, Organizational Creativity, OD in International Context.

UNIT-V

Perspectives of Organisation Development: Learning Organisation, Knowledge Management and OD, Organisational Design and Work Culture, Organisational Restructuring.

Text Books:

1. Sharma, R. C., & Sharma, S. (2024). Human Resource Management: Concepts, Theories and Contemporary Practices. Routledge India, ISBN: 9781032628370
2. Gupta, C. B. (2023). Human Resource Management (3rd ed.). Sultan Chand & Sons. ISBN: 9789351611660.

Reference Books:

1. Kandula, S. R. (2020). Organizational Development and Change. PHI Learning Pvt. Ltd, ISBN: 9788120356344
2. Mishra, S. (2024). The Essence of Reinvented OD: A Study on Organization Development & Organizational Development. IOSR Journals, DOI: 10.9790/487X-2611140107

Web Links:

1. <https://archive.nptel.ac.in/courses/110/101/110101146/>
2. <https://archive.nptel.ac.in/courses/110/101/110101146/>

Relevant cases have to be discussed in each unit and in examination case study is compulsory from any unit.

CONTEMPORARY PRACTICES IN HR

	L	T	P	C
Course Code: 2508MS22	2		1	3

Course Outcomes:

At the end of the Course, Student will be able to:

- CO1:** Explain Contemporary trends towards a new HR
- CO2:** Develop knowledge on regulations and public policy influenced by social trends, change management and people's completion in labor market.
- CO3:** Identify HR expectations and help to enhance their knowledge and engagement
- CO4:** Determine the management of international workforce and build knowledge on how to opt ethical decision and strategies.
- CO5:** Examine various functions to evaluate and manage Human Resources.

Mapping of Course Outcomes with Program Outcomes:

CO / PO	PO1	PO2	PO3	PO4	PO5	PO6	PO7	PO8
CO1	3	2	2	2	3	3	2	2
CO2	2	3	2	3	3	3	3	3
CO3	3	3	3	3	3	2	3	3
CO4	3	3	3	3	3	3	3	2
CO5	3	3	3	3	3	3	3	3

Mapping of Course Outcomes with Program Specific Outcomes:

CO / PSO	PSO1	PSO2	PSO3
CO1	3	2	2
CO2	3	3	2
CO3	3	3	3
CO4	3	3	3
CO5	3	3	3

UNIT – I

Introduction: Contemporary trends towards a new HR, Future agendas, Competition and choice– Introduction, Competitive intensity, Financialization, The impact of increased competitive intensity. People and skills - Demand for people, Supply of people, Demand for skills, Supply of skills, The hourglass metaphor.

UNIT – II

Regulation and Public Policy: A regulatory revolution, Contemporary debates, Likely future developments, The wider public policy agenda. Social trends- Affluence and inequality, Individualism, Ethical awareness. Flexibility and change-Change management, Managing the consequences of change, Flexible working. Competing for people-Reward, Employer branding, Labor market segmentation.

UNIT – III

Managing Expectations: Hopes and expectations, Expectancy theory, Equity theory, psychological contracts, managing expectations in practice, are expectations changing. Engaging people- Defining engagement, Current interest in engagement, Benefits for employees, Benefits for employers, improving

levels of employee engagement, Criticisms of employee engagement initiatives, Line management Managing; knowledge and learning-Human capital, Knowledge management, learning organizations, Managing knowledge workers

UNIT – IV

Managing an International Workforce: Convergence and divergence, Cultural differences, Institutional differences, Expatriates, culturally diverse teams, Structural issues. Managing ethically - Ethical decision-making in HRM, theory, Ethical decision-making in HRM, practice, Equality and diversity. Developing HR Strategies- Alternative conceptions of HR strategy, Contingency models, positioning an organization in the labor market, Contemporary approaches to human resource planning.

UNIT – V

Managing the HR Function: Adding value, Outsourcing, Ulrich's models Evaluating the HR contribution, Evaluation criteria, Evaluation methods and Cutting-edge approaches to evaluation.

Text Books:

1. Sharma, R. C., & Sharma, S. (2024). Human Resource Management: Concepts, Theories and Contemporary Practices. Routledge India. ISBN: 9781032628370.
2. Gupta, C. B. (2023). Human Resource Management (3rd ed.). Sultan Chand & Sons. ISBN: 9789351611660.

Reference Books:

1. Shahani, P. (2020). Queeristan: LGBTQ Inclusion in the Indian Workplace. Westland Business. ISBN: 9789389648881
2. Rajesh, S. (2024). Conversations with the Career Doctor: Women Thriving and Winning at Work. Penguin Random House India. ISBN: 9780670099305

Web Links:

1. <https://srmuniv.digimat.in/nptel/courses/video/122105020/L22.html>
2. <https://www.youtube.com/watch?v=E5mvG6jrDjo>

Relevant cases have to be discussed in each unit and in examination case study is compulsory from any unit.

INDUSTRIAL RELATIONS

	L	T	P	C
Course Code: 2508MS43	2		1	3

Course Outcomes:

At the end of the Course, Student will be able to:

- CO1:** Explain the concept and background of industrial relations in India.
- CO2:** Identify the growth, objectives, and legal framework of trade unions in India.
- CO3:** Analyze the concept and levels of workers' participation in management.
- CO4:** Assess the provisions of the Workmen Compensation Act and Employees' State Insurance Act concerning social security.
- CO5:** Discover the causes of employee grievances

Mapping of Course Outcomes with Program Outcomes:

CO / PO	PO1	PO2	PO3	PO4	PO5	PO6	PO7	PO8
CO1	3	2	2	3	3	2	2	2
CO2	3	3	2	3	3	2	3	3
CO3	3	3	3	2	2	2	3	3
CO4	3	3	2	3	2	3	2	3
CO5	3	3	3	2	3	2	3	3

Mapping of Course Outcomes with Program Specific Outcomes:

CO / PSO	PSO1	PSO2	PSO3
CO1	3	2	2
CO2	3	3	2
CO3	3	3	3
CO4	3	3	3
CO5	3	3	3

UNIT – I

Industrial Relations Management: Concept- Evaluation –Background of industrial Relations in India- Influencing factors of IR in enterprise and the consequences. Economic, Social and Political environments- Employment Structure –Social Partnership-Wider approaches to industrial relations- Labor Market.

UNIT – II

Trade Unions: Introduction-Definition and objectives-growth of Trade Unions in India-trade Unions Act, 1926 and Legal framework-Union recognition-Union Problems-Employees Association-introduction, Objective Membership, Financial Status.

UNIT – III

Quality of Work Life: Workers' Participation in Management - Worker's Participation in India, shop floor, Plant Level, Board Level- Workers' Welfare in Indian scenario- Collective bargaining concepts & Characteristics –Promoting peace. Wage and Salary administration: Nature & Significance of wage, salary administration, essentials- Minimum wage- Fair wage, Real wage, Incentives & fringe benefits. Issues and Constraints in Wage Determination in India.

UNIT – IV

Social Security: Introduction and types –Social Security in India, Health and Occupational safety programs- Salient features of Workmen Compensation Act and Employees’ State Insurance Act relating to social security – Workers’ education objectives -Rewarding.

UNIT – V

Employee Grievances: Causes of Grievances –Conciliation, Arbitration and Adjudication procedural aspects for Settlement of Grievances –Standing Orders- Code Discipline. Industrial Disputes: Meaning, nature and scope of industrial disputes - Cases and Consequences of Industrial Disputes –Prevention and Settlement of industrial disputes in India- Industrial Disputes act 1947- works committees, conciliation officers, boards of conciliation, labour courts, industrial tribunals, and national tribunals.

Text Books:

1. Srivastava, S. C. (2022). Industrial Relations and Labour Laws (8th ed.). Vikas Publishing House. ISBN: 9789354539961
2. Gupta, C. B., Kapoor, N. D., & Tripathi, P. C. (2020). Industrial Relations and Labour Laws. Sultan Chand & Sons. ISBN: 9789351611660

Reference Books:

1. Gupta, P. (2023). Industrial Relations & Labour Laws for Managers (2nd ed.). Taxmann Publications. ISBN: 9789356226944
2. Taxmann's Editorial Board. (2023). Labour Laws. Taxmann Publications. ISBN: 9789357781268

Web Links:

1. <https://nptel.ac.in/courses/110103506>
2. <https://enine.digimat.in/nptel/courses/video/122102007/L21.html>

Relevant cases have to be discussed in each unit and in examination case study is compulsory from any unit.

LABOUR WELFARE AND LEGISLATION

Course Code: 2508MS52

L	T	P	C
2		1	3

Course Outcomes:

At the end of the Course, Student will be able to:

- CO1:** Explain the key provisions and implications of major welfare legislations in India.
- CO2:** Identify the fundamental aspects of industrial relations legislation, including the Industrial Disputes Act, Industrial Employment Act, and Trade Unions Act.
- CO3:** Examine the main provisions of wage and social security legislation
- CO4:** Analyze the role of the Indian constitution and various agencies in promoting labor welfare.
- CO5:** Classify statutory and non-statutory labor welfare programs.

Mapping of Course Outcomes with Program Outcomes:

CO / PO	PO1	PO2	PO3	PO4	PO5	PO6	PO7	PO8
CO1	3	2	2	3	2	2	3	2
CO2	3	3	2	3	2	2	3	3
CO3	3	3	2	3	3	2	3	3
CO4	3	3	3	2	3	3	3	3
CO5	3	3	3	2	3	2	3	3

Mapping of Course Outcomes with Program Specific Outcomes:

CO / PSO	PSO1	PSO2	PSO3
CO1	3	2	2
CO2	3	3	2
CO3	3	3	3
CO4	3	3	3
CO5	3	3	3

UNIT – I

Labour Welfare Legislation: The Factories Act, 1948, The Mines Act, 1952, The Plantation Labor Act, 1951, The Contract Labor (Regulation and Abolition) Act, 1970 and The Andhra Pradesh. Shops and Establishments Act, 1988.

UNIT – II

Industrial Relations Legislation: The Industrial Disputes Act, 1947; The Industrial Employment (standing orders) Act, 1946 and Trade Unions Act 1926.

UNIT – III

Wage and Social Security Legislation: The Payment of wages Act, 1936, The Minimum wages Act, 1948, The Payment of Bonus Act, 1966, The Payment of Gratuity Act, 1972, The Workmen’s Compensation Act, 1923, The Employees State Insurance Act, 1948, The Maternity Benefit Act, 1961, The Employees Provident Fund and Miscellaneous Provisions Act, 1952.

UNIT – IV

Labor Welfare: Concept, scope and philosophy, principles of labor welfare, Indian constitution on labor, Agencies of labor welfare and their roles. ILO, Impact of ILO on labor welfare in India.

Labor problems – Indebtedness, Absenteeism, Alcoholism, Personal and Family Counselling.

UNIT – V

Labor Welfare Programmes: Statutory and non-statutory, extra mural and intra mural, Central Board of Workers' Education; Workers' Cooperatives; Welfare Centers, Welfare Officers' Role, Status and Functions. Role of social work in industry

Text Books:

1. Goswami, V. G. (2021). Labour and Industrial Laws. Central Law Agency. ISBN: 9788194003663,
2. Kumawat, B. (2020). Labour Welfare Laws: For B.Com Vth Semester of Lucknow University. Sahitya Bhawan Publications. ISBN: 9789389797367

Reference Books:

1. Kumar, H. L. (2024). Practical Guide to Contract Labour Regulation & Abolition Act, 12th Edn. Law & Justice Publishing Co. ISBN: 978-81-19129-53-9.
2. Kumar, H. L. (2024). Practical Guide to Payment of Gratuity Act & Rules, 13th Edn. Law & Justice Publishing Co. ISBN: 978-81-19129-47-8.

Web Links:

1. https://onlinecourses.nptel.ac.in/noc24_mg104/preview
2. <https://www.youtube.com/watch?v=KpsTCmK6TbU>

Relevant cases have to be discussed in each unit and in examination case study is compulsory from any unit.

COMPENSATION AND REWARD MANAGEMENT

Course Code: 2508MS19	L	T	P	C
	2		1	3

Course Outcomes:

At the end of the Course, Student will be able to:

CO1: Explain the fundamental concepts and theories of compensation management

CO2: Analyze various pay structures based on job analysis and evaluation.

CO3: Identify different types of employee benefits and rewards

CO4: Examine the key provisions of Legislation and Compensation Acts.

CO5: Simplify the concept of expatriate Compensation.

Mapping of Course Outcomes with Program Outcomes:

CO / PO	PO1	PO2	PO3	PO4	PO5	PO6	PO7	PO8
CO1	3	2	3	3	2	2	3	2
CO2	3	3	2	3	2	2	3	3
CO3	3	2	2	3	3	2	3	3
CO4	3	3	2	2	3	3	3	3
CO5	3	3	3	3	3	2	3	3

Mapping of Course Outcomes with Program Specific Outcomes:

CO / PSO	PSO1	PSO2	PSO3
CO1	3	2	2
CO2	3	3	2
CO3	3	2	2
CO4	3	3	3
CO5	3	3	3

UNIT – I

Compensation Management An Introduction to Compensation Management, Theories of Compensation management, 3–P Concept in Compensation Management, Strategic Compensation Management, Strategic and Tactical Compensation Issues.

UNIT – II

Job Design, Job Evaluation and Compensation structures Job Analysis & Design, Job evaluation and methods, understanding market pay and benchmarking, latest pay band - Base pay, Performance based pay, Broad banding, Pay-for-Skills / Skill-Based Pay, Competency-Based Pay, Team-Based Pay, Pay Transparency and Equity Trends, Hybrid Pay Structures.

UNIT – III

Benefits and Services Employee benefits and rewards, Long–term and Short–term benefits and rewards, Administration of benefits and the influencing factors, Employee welfare and services,

UNIT – IV

Legalization and Compensation The legislative process – Payment of Wages Act 1936, Employees Insurance Act 1948, Workers Compensation Act 1923, Employees Provident Fund Act 1952.

UNIT – V

Executive and International Compensation Executive compensation – concepts and elements, Quantitative tools, Expatriate Compensation and its Objectives, Elements of Expatriate’s Compensation Package, Laws relating compensation.

Text Books:

1. Sharma, R. C., & Sharma, S. (2024). Compensation and Reward Management: Wage and Salary Administration and Benefits. Routledge India. ISBN: 9781032626116
2. Kamaksha. (2024). MMPH-007: Compensation and Reward Management (IGNOU Study Guide Book). Gyaniversity Publications. ISBN: 9789362458360

Reference Books:

1. Ghosh, B. (2022). Compensation & Reward Management. Sterling Publishers (P) Ltd. ISBN: 9788120777422
2. Shaikh, M. W. (2022). Compensation and Reward Management. eBooks2go. ISBN: 9781545755587

Web Links:

1. <https://dituniversity.digimat.in/nptel/courses/video/110105069/L10.html>
2. https://www.youtube.com/watch?v=iY6e_NDCJgM

Relevant cases have to be discussed in each unit and in examination case study is compulsory from any unit.

MAJOR 4: BUSINESS ANALYTICS (BA)

DATA ANALYSIS WITH PYTHON

Course Code: 2508MS26	L	T	P	C
	2		1	3

Course Outcomes:

At the end of the Course, Student will be able to:

- CO1:** Explain basic Python programming concepts to solve simple business analytics problems.
- CO2:** Apply data handling techniques using Pandas for basic business analysis such as sales, customer segmentation, and HR attrition.
- CO3:** Apply data visualization techniques using Matplotlib and Seaborn to interpret market trends, customer demographics, and financial KPIs.
- CO4:** Analyze business data using statistical methods such as descriptive statistics, hypothesis testing, and regression to support data-driven decision making.
- CO5:** Analyze and solve real-world business problems by applying data analytics techniques and interpreting results in a business context.

Mapping of Course Outcomes with Program Outcomes:

CO / PO	PO1	PO2	PO3	PO4	PO5	PO6	PO7	PO8
CO1	3	2	3	2	3	3	2	2
CO2	3	3	3	2	3	3	3	2
CO3	3	3	2	3	3	3	3	2
CO4	3	2	3	3	3	3	3	3
CO5	3	3	3	3	3	3	3	3

Mapping of Course Outcomes with Program Specific Outcomes:

CO / PSO	PSO1	PSO2	PSO3
CO1	3	2	2
CO2	3	3	2
CO3	3	3	2
CO4	3	2	3
CO5	3	3	3

UNIT – I

Introduction to Python for Business: Why Python for business analytics? Installing Python and Jupyter Notebooks, Basic syntax, variables, data types, Lists, tuples, dictionaries, sets, Conditional statements, loops, and functions, Business use cases: ROI calculation, simple pricing models

UNIT – II

Data Handling with Pandas: Introduction to Pandas library, DataFrames and Series, Importing/exporting data (CSV, Excel), Handling missing data, Data filtering and selection, Grouping and aggregations, Merging and joining datasets, Business use cases: Sales data, customer segmentation, HR attrition data

UNIT – III

Data Visualization with Matplotlib & Seaborn: Introduction to Matplotlib, Line plots, bar charts, pie charts, Introduction to Seaborn, Histograms, boxplots, scatter plots, heatmaps, Customizing plots (titles, labels, legends), Business use cases: Market trends, customer demographics, financial KPIs

UNIT – IV

Statistical Analysis for Business Decisions: Descriptive statistics: mean, median, mode, standard deviation, Correlation and covariance, Probability distributions, Hypothesis testing (t-test, chi-square), Linear regression, Business use cases

UNIT – V

Capstone Project / Business Data Hackathon: Problem definition and dataset selection, Data cleaning and preprocessing, Exploratory data analysis and visualization, Application of statistical and predictive techniques, Interpretation of results in business context, Report writing and presentation

Text Books:

1. Wes McKinney, Python for Data Analysis, O'Reilly Media publishers, ISBN 13 978-1491957660
2. Foster Provost and Tom Fawcett, Data Science for Business, O'Reilly Media publishers, ISBN 13 978-1449374266

Reference Books:

1. Kaggle, Analytics Vidhya, Towards Data Science (Medium)

Web Links:

1. https://onlinecourses.nptel.ac.in/noc21_cs45/preview
2. <https://nptel.ac.in/courses/106107220>

Relevant cases have to be discussed in each unit and in examination case study is compulsory from any unit.

MARKETING ANALYTICS

Course Code: 2508MS63

L	T	P	C
2		1	3

Course Outcomes:

At the end of the Course, Student will be able to:

- CO1:** Explain the Concepts of Marketing Analytics and their relevance in business,
- CO2:** Make use of MS Excel to deal with Marketing Data at basic level,
- CO3:** Appreciate Customer’s journey through Product Selection Process and Customer Lifetime Value,
- CO4:** Conduct Analysis in Determining the Pricing Strategies
- CO5:** Analyze the Process of Optimizing Clusters and Measure the Effectiveness of Promotion

Mapping of Course Outcomes with Program Outcomes:

CO / PO	PO1	PO2	PO3	PO4	PO5	PO6	PO7	PO8
CO1	3	3	3	2	3	3	2	2
CO2	3	3	3	2	3	3	2	2
CO3	3	3	3	3	3	3	3	2
CO4	3	3	3	3	3	3	2	2
CO5	3	3	3	3	3	3	3	3

Mapping of Course Outcomes with Program Specific Outcomes:

CO / PSO	PSO1	PSO2	PSO3
CO1	3	2	3
CO2	3	3	3
CO3	3	3	3
CO4	3	3	3
CO5	3	3	3

UNIT – I

Introduction to Marketing Analytics: Definition, Need and Scope of Marketing Analytics, Marketing Analytics Vs. Marketing Research, Levels in Marketing Analytics, Adoption and Application of Marketing Analytics, Marketing Analytics and Business Intelligence. MS Excel as a Tool for conduction of Marketing Analytics. Using MS Excel to Organize and Summarize Marketing Data: Creation of Pivot Tables and Organizing Data.

UNIT – II

Summarizing Marketing Data: Summarizing Revenue Data: Month-wise and Product-wise. Slicing & Dicing of Data: Pareto Principle, Report Filters and Slicers. Demographic Analysis: Analyzing Sales Data by Age, Gender, Income and Location, Construction of Crosstabs of Two Demographic Variables. Using GETPIVOT Function for Pulling Data. Adding Data Labels and Data Tables.

UNIT – III

Customer Analytics: Customer Journey Mapping, Tracking Customer Experience Metrics, Customer Feedback, Behavior Metrics, Building Customer Persona, Conjoint Analysis for Product Choices, Customer Lifetime Value (CLV), Calculating CLV, Sensitivity Analysis, Estimating Customer Activity.

UNIT – IV

Pricing Analytics: Pricing, Goals of Pricing, Price Elasticity, Estimating Linear and Power Demand Curves, Using Excel Solver to Optimize Price, Incorporating Complementary Products, Using Solver Table to Price Multiple Products and Finding Demand Curve for All Products. Price Bundling, Bundling Prices to Extract Consumer Surplus, Mixed Bundling, Using Evolutionary Solver to Find Optimal Bundle Prices. Price Skimming.

UNIT – V

Segmentation & Promotion Analytics: Cluster Analysis, Location-wise Clustering, Solver for Optimal Clusters, Conjoint Analysis, Decision Trees for Market Segmentation, Types of Promotions, Discounting, Adstock Model for Advertising Effectiveness, Media Selection Models, Linear Media Allocation, Quantity Discounts, Monte Carlo Simulation, Pay per Click Advertising.

Text Books:

1. Gupta, S., & Jathar, A. (2020). Marketing Analytics. Wiley India, ISBN: 978-9354242625
2. Palmatier, R. W., & Petersen, J. A. (2022). Marketing Analytics: Based on First Principles. Bloomsbury Publishing India, ISBN: 978-9356400634.

Reference Books:

1. Charan, A. (2020). A Practitioner's Guide to Marketing Analytics and Research Methods. World Scientific, ISBN: 978-0000988881.
2. Dheenadhayalan, V., & Vijai, C. (2023). Contemporary Research in Commerce and Management. Sankalp Publications, ISBN: 978-9394901711

Web Links:

1. https://onlinecourses.nptel.ac.in/noc20_mg30/previe
2. <https://www.superheuristics.com/marketing-analytics-using-excel/>

Relevant cases have to be discussed in each unit and in examination case study is compulsory from any unit.

FINANCIAL ANALYTICS

Course Code: 2508MS37

L	T	P	C
2		1	3

Course Outcomes:

At the end of the Course, Student will be able to:

- CO1:** Examine financial statements to interpret organizational financial health.
- CO2:** Apply time value of money and risk-return measures to make financial decisions.
- CO3:** Analyze investment opportunities using capital budgeting techniques
- CO4:** Assess equity valuations and perform industry, economic, and technical analysis.
- CO5:** Interpret bond valuation and immunization strategies to manage fixed-income portfolios effectively.

Mapping of Course Outcomes with Program Outcomes:

CO / PO	PO1	PO2	PO3	PO4	PO5	PO6	PO7	PO8
CO1	3	3	3	2	3	3	2	2
CO2	3	3	3	3	3	3	2	2
CO3	3	3	3	3	3	3	2	3
CO4	3	3	3	3	3	3	2	3
CO5	3	3	3	3	3	3	3	3

Mapping of Course Outcomes with Program Specific Outcomes:

CO / PSO	PSO1	PSO2	PSO3
CO1	3	3	2
CO2	3	3	3
CO3	3	3	3
CO4	3	3	3
CO5	3	3	3

UNIT – I

Techniques of Financial Statement: Horizontal, Vertical Analysis, Trend Analysis, Ratio Analysis, Liquidity, Profitability, Solvency and Turnover Ratio, Valuation of Ratios, Statement of Cash Flow, Classification of Cash Flow, Computing Net Cash Flow: Operating, Investing and Financing Activities. Reporting and Interpretation using Spreadsheet.

UNIT – II

Time Value of Money: Future Value: Simple, Compound Interest and Annuity, Present Value: Discounted, Annuity, Equated Loan Amortization, Perpetuity using Spreadsheets. Risk and Return- Holding Period Returns, Arithmetic Mean vs Geometric Mean, Risk: Standard Deviation, Coefficient of Variation, Beta, Covariance of Stock.

UNIT – III

Capital Budgeting Techniques: Payback Period, Accounting Rate of Return, Net Present Value, Internal Rate of Return, Profitability Index, Decision Tree, Cash Flow in Capital Budgeting, Cost of Capital, Advance Capital Budgeting Techniques, Adjusted Present Value Approach, Competing Project Risk using Spreadsheets.

UNIT – IV

Equity Valuation: Calculation of Portfolio Mean and Variance, Capital Asset Pricing Model (CAPM), Variance: Covariance Matrix, Estimating Beta and Security Market Line. Industry Analysis, Economic Analysis and Technical Analysis in Stock, Real Option in Capital Budgeting.

UNIT – V

Bond Valuation: Duration, Duration of Bond with Uneven Payments, Immunization Strategies, Modelling the Term Structure, Calculating Expecting Bond Return in a Single and Multi-period Framework, Semi-annual Transition Matrix, Computation of Bond Beta.

Text Books:

1. Mohanty, P. (2023). Financial Analytics. Wiley India, ISBN: 978-9354644177
2. Kalkar, P., Gosavi, P., & Adkar, V. (2021). Financial Analytics. Indian Books and Periodicals, ISBN: 978-9354952197.

Reference Books:

1. Anuradha, B. (2021). Financial Analytics and Control. Notion Press, ISBN: 978-1639749690.
2. Dheenadhayalan, V., & Vijai, C. (2023). Contemporary Research in Commerce and Management. Sankalp Publications, ISBN: 978-9394901711.

Web Links:

1. <https://www.coursera.org/learn/applying-data-analytics-business-in-finance>
2. <https://www.udemy.com/course/financial-analytics-excel-tableau/>

Relevant cases have to be discussed in each unit and in examination case study is compulsory from any unit.

HR ANALYTICS

Course Code: 2508MS41

L	T	P	C
2		1	3

Course Outcomes:

At the end of the Course, Student will be able to:

- CO1:** Develop an understanding of the relevance of HR Analytics in the current scenario.
- CO2:** Explain the models of conducting HR Analytics
- CO3:** Make use of MS Excel for conduction of HR Analytics for key HR Processes
- CO4:** Classify various tools and software technologies used for conduction of descriptive HR Analytics and Visualization of HR Data.
- CO5:** Assess the significance of Predictive and Prescriptive Analytics.

Mapping of Course Outcomes with Program Outcomes:

CO / PO	PO1	PO2	PO3	PO4	PO5	PO6	PO7	PO8
CO1	3	2	3	3	3	3	3	2
CO2	3	3	3	3	3	2	3	3
CO3	3	3	3	2	3	3	2	3
CO4	3	3	3	3	3	3	3	3
CO5	3	3	3	3	3	3	3	3

Mapping of Course Outcomes with Program Specific Outcomes:

CO / PSO	PSO1	PSO2	PSO3
CO1	3	2	2
CO2	3	3	3
CO3	3	3	3
CO4	3	3	3
CO5	3	3	3

UNIT – I

Introduction to HR Analytics: History of Different HRM Perspectives, Transition from HRM to HCM and Gaining Sustainable Advantage through HCM. HR Analytics and Changing Role of HR Professionals. Importance, Scope and Benefits of HR Analytics. Levels of Analysis and Conducting analytics. Key Influencers of HR Analytics Process. Big Data Era in HR Analytics, HR Analytics – Linkage to Business Outcomes.

UNIT – II

Understanding HR Analytics: Conducting HR Analytics: Models of HR Analytics, How to Conduct HR Analytics. Understanding HR Data: Importance of Data, Types and Scales of Data, Methods of Capturing Data, Data Examination & Purification. Understanding various HR Metrics from the perspective of HR Analytics.

UNIT – III

Analytics for Key HR Processes Using MS Excel: HR Analytics for Recruitment & Selection, Training & Development, Performance Appraisal, Talent Management, Employee Engagement, Compensation Management, Compensation benchmarking and revolt forecasting, Expatriate Management.

UNIT – IV

Descriptive Analytics: Overview of Select Tools for Conduction HR Analytics: MS Excel, Power BI, Python, SPSS. Descriptive Analytics in HR: HR Dashboards using MS Excel, Slicing and Dicing of HR Data using MS Excel Pivot Table Applications, Data Visualization for Key HR processes.

UNIT – V

Predictive & Prescriptive HR Analytics: Predictive HR Analytics: Correlation, Linear and Multiple Regression, Factor Analysis and Cluster Analysis, Comparison of Means and Analysis of Variance for Manpower Demographics, Employee Satisfaction, And Training Effectiveness etc. Prescriptive HR Analytics, Predictive vs Prescriptive HR Analytics, Future of HR Analytics.

Text Books:

1. Walsh, M. J. (2021). HR Analytics Essentials You Always Wanted To Know. Vibrant Publishers, ISBN: 978-1636510347
2. Kumar, P., Rao, S. K., & Nayana, N. (2021). Fundamentals of HR Analytics. IIP Books, ISBN: 978-1956102840

Reference Books:

1. Qin, C., Zhang, L., Cheng, Y., Zha, R., Shen, D., Zhang, Q., Chen, X., Sun, Y., Zhu, C., & Xiong, H. (2023). A Comprehensive Survey of Artificial Intelligence Techniques for Talent Analytics. arXiv.
2. Leidner, J. L., & Stevenson, M. (2024). Challenges and Opportunities of NLP for HR Applications: A Discussion Paper. arXiv..

Web Links:

1. https://onlinecourses.nptel.ac.in/noc24_hs126/preview
2. <https://www.coursera.org/learn/human-resources-analytics>

Relevant cases have to be discussed in each unit and in examination case study is compulsory from any unit.

TIME SERIES FORECASTING AND DATA VISUALIZATION

Course Code: 2508MS87	L	T	P	C
	2		1	3

Course Outcomes:

At the end of the Course, Student will be able to:

- CO1:** Explain time series data components, visualization, smoothing, and decomposition techniques.
- CO2:** Apply preprocessing, feature engineering, and stationarity testing techniques for time series data.
- CO3:** Evaluate various time series forecasting models using appropriate techniques and error metrics.
- CO4:** Apply advanced machine learning techniques for time series forecasting and evaluate models for business insights.
- CO5:** Design and implement interactive time series dashboards and execute a full forecasting project with business insights.

Mapping of Course Outcomes with Program Outcomes:

CO / PO	PO1	PO2	PO3	PO4	PO5	PO6	PO7	PO8
CO1	3	3	3	3	3	3	3	3
CO2	3	3	3	3	3	3	2	3
CO3	3	3	3	3	3	2	3	2
CO4	3	3	3	3	3	2	3	3
CO5	2	3	3	2	2	3	3	2

Mapping of Course Outcomes with Program Specific Outcomes:

CO / PSO	PSO1	PSO2	PSO3
CO1	3	3	3
CO2	3	3	3
CO3	3	3	3
CO4	3	3	3
CO5	3	3	3

UNIT – I

Introduction to Time Series Data and Visualization: Time series components – trend, seasonality, cycles, Time index, frequency, date-time formats, Types – univariate vs. multivariate, stationary vs. non-stationary, Plotting with Matplotlib and Pandas, Smoothing – moving average, exponential smoothing, Decomposing series into trend, seasonality, residuals.

UNIT – II

Time Series Preprocessing and Feature Engineering: Handling missing values and outliers, Time-based indexing, slicing, resampling, Feature extraction – hour, day, week, lag features, Stationarity testing – ADF test, transformations – log, sqrt, Box-Cox, ACF and PACF plots for pattern detection.

UNIT – III

Forecasting Models for Time Series: Basics of forecasting and model evaluation, Naive, moving average, exponential smoothing methods, Holt’s linear trend and Holt-Winters seasonal models, AR, MA, ARMA, ARIMA models – theory and use, Model selection – AIC, BIC, Error metrics – MAE, MSE, RMSE, MAPE.

UNIT – IV

Advanced Forecasting with Machine Learning: Regression-based forecasting models, Train/test split based on time, Random Forest, Gradient Boosting (XGBoost), Intro to LSTM – conceptual overview, Multi-step forecasting, ensemble models, hyperparameter tuning, Evaluating models for business insights.

UNIT – V

Interactive Dashboards and Capstone Project: Data visualization with Plotly, Seaborn, Interactive dashboards with Dash or Streamlit, Building KPIs, dynamic filters for business, Capstone – full project from preprocessing to dashboard, Project presentation with business impact.

Text Books:

1. Practical Time Series Analysis: Prediction with Statistics and Machine Learning”, Aileen Nielsen, Publisher: O’Reilly Media
2. “Python for Data Analysis: Data Wrangling with Pandas, NumPy, and IPython”, Wes McKinney, Publisher: O’Reilly Media

Reference Books:

1. “Introduction to Time Series and Forecasting”, Peter J. Brockwell and Richard A. Davis, Publisher: Springer

Web Links:

1. <https://blog.streamlit.io/forecasting-with-streamlit-prophet/>
2. <https://codezup.com/build-time-series-dashboards-python/>

Relevant cases have to be discussed in each unit and in examination case study is compulsory from any unit.

BIG DATA ANALYTICS

Course Code: 2508MS07

L	T	P	C
2		1	3

Course Outcomes:

At the end of the Course, Student will be able to:

- CO1:** Explain big data futures and classification of analytics
- CO2:** Develop knowledge on analytics flow for big data and big data stack
- CO3:** Analyze big data tool using Hadoop
- CO4:** Identify the security related aspects in big data
- CO5:** Discover various application areas of big data

Mapping of Course Outcomes with Program Outcomes:

CO / PO	PO1	PO2	PO3	PO4	PO5	PO6	PO7	PO8
CO1	3	3	3	3	3	3	3	3
CO2	3	3	3	3	3	3	3	3
CO3	3	3	3	3	3	3	3	3
CO4	3	3	3	3	3	3	3	3
CO5	3	3	3	3	3	3	3	3

Mapping of Course Outcomes with Program Specific Outcomes:

CO / PSO	PSO1	PSO2	PSO3
CO1	3	3	3
CO2	3	3	3
CO3	3	3	3
CO4	3	3	3
CO5	3	3	3

UNIT – I

Introduction to Big Data: What is Analytics- Descriptive Analytics, Diagnostic Analytics, Predictive Analytics and Prescriptive Analytics? What is Big Data- Characteristics of Big Data- Volume, Velocity, Variety, Veracity and Value?

UNIT – II

Analytics Flow and Big Data Stack: Analytics Flow for Big Data- Data Collection, Data Preparation, Analysis Types, Analysis Modes, Visualizations, Big Data Stack- Raw Data Sources, Data Access Connectors, Data Storage, Batch Analytics, Real-time Analytics, Interactive Querying, Serving Databases, Web & Visualization Frameworks, web scraping and API Integration.

UNIT – III

Big Data -Hadoop: NoSQL, Comparison of SQL and NoSQL, Hadoop -RDBMS Versus Hadoop - Distributed Computing Challenges – Hadoop Overview - Hadoop Distributed File System – Processing Data with Hadoop - Managing Resources and Applications with Hadoop YARN - Interacting with Hadoop Ecosystem – SPARK and SCALA

UNIT – IV

Security in Big Data: Security, compliance, auditing, and protection pragmatic steps to securing/ big data -classifying data- protecting big data analytics- big data and compliance-the intellectual property challenge.

UNIT – V

Big Data Applications: Business Specification Examples of Big Data- Financial, Web, Healthcare, Internet of Things, Environment, Logistics & Transportation, Industry, Retail.

Text Books:

1. Shikhman, V., & Müller, D. (2021). Mathematical Foundations of Big Data Analytics. Springer Gabler, ISBN: 978-3-662-62520-0.
2. Demirbaga, Ü., Aujla, G. S., Jindal, A., & Kalyon, O. (2024). Big Data Analytics: Theory, Techniques, Platforms, and Applications. Springer, ISBN: 978-3-031-55638-8.

Reference Books:

1. Pani, S. K., Tripathy, S., Jandieri, G., Kundu, S., & Butt, T. A. (2021). Applications of Machine Learning in Big-Data Analytics and Cloud Computing. River Publishers, ISBN: 978-87-7022-182-5.
2. Marr, B. (2022). Big Data in Practice: How 45 Successful Companies Used Big Data Analytics to Deliver Extraordinary Results. Wiley, ISBN: 978-1-119-23138-7

Web Links:

1. https://onlinecourses.swayam2.ac.in/arp19_ap60/preview
2. <https://www.coursera.org/specializations/big-data>

Relevant cases have to be discussed in each unit and in examination case study is compulsory from any unit.

WEB ANALYTICS

	L	T	P	C
Course Code: 2508MS90	2		1	3

Course Outcomes:

At the end of the Course, Student will be able to:

- CO1:** Explain the importance of analytics in the context of social media and websites, emphasizing the role of data - driven decision – making.
- CO2:** Familiarize participants with fundamental metrics used in web analytics and social media analytics.
- CO3:** Identify the key performance indicators (KPIs) for social media and web analytics.
- CO4:** Show how to set up and track conversions on websites and social media platforms and understand the customer journey and optimize for conversion goals.
- CO5:** Analyze the concepts of social listening and monitoring and use tools to monitor brand mentions, track sentiment, and stay informed about industry trends.

Mapping of Course Outcomes with Program Outcomes:

CO / PO	PO1	PO2	PO3	PO4	PO5	PO6	PO7	PO8
CO1	3	3	3	3	3	3	3	3
CO2	3	3	3	3	3	3	3	3
CO3	3	3	3	3	3	3	3	3
CO4	3	3	3	3	3	3	3	3
CO5	3	3	3	3	3	3	3	3

Mapping of Course Outcomes with Program Specific Outcomes:

CO / PSO	PSO1	PSO2	PSO3
CO1	3	3	3
CO2	3	3	3
CO3	3	3	3
CO4	3	3	3
CO5	3	3	3

UNIT – I

Introduction- Introduction to Web - Limitations of current Web – Development of Semantic Web– Emergence of the Social Web – Statistical Properties of Social Networks - Network analysis -Development of Social Network Analysis - Key concepts and measures in network analysis -Discussion networks - Blogs and online communities - Web-based networks.

UNIT – II

Modeling and Visualization- Visualizing Online Social Networks - A Taxonomy of visualizations - Graph Representation - Centrality- Clustering - Node-Edge Diagrams - visualizing Social Networks with Matrix-Based Representations- Node-Link Diagrams – Hybrid Representations - Modeling and aggregating social network data – Random Walks and their Applications –Use of Hadoop and Map Reduce – Ontological representation of social individuals and relationships.

UNIT – III

Mining Communities- Aggregating and reasoning with social network data- Advanced Representations - Extracting evolution of Web Community from a Series of Web Archive -Detecting Communities in Social Networks - Evaluating Communities – Core Methods for Community Detection & Mining - Applications of Community Mining Algorithms – Node Classification in Social Networks.

UNIT – IV

Text and Opinion Mining- Text Mining in Social Networks -Opinion extraction – Sentiment classification and clustering - Temporal sentiment analysis - Irony detection in opinion mining - Wish analysis - Product review mining – Review Classification – Tracking sentiments towards topics over time.

UNIT – V

Tools for Social Network Analysis- UCINET – PAJEK – ETDRAW – Stoc NET – Splus –R – NodeXL – SIENA and RSIENA – Real world Social Networks (Facebook- Twitteretc.)

Text Books:

1. Allison, K. (2021). Digital Analytics: The Path from Clicks to Conversions. Sentia Publishing, ISBN: 978-1-734-56789-0
2. Hair, J. F., Harrison, D. E., & Ajjan, H. (2021). Essentials of Marketing Analytics, McGraw-Hill Education, ISBN: 978-1-260-57777-1

Reference Books:

1. The Art of Service. (2021). Google Analytics: A Complete Guide – 2021 Edition. The Art of Service, ISBN: 978-1-867-42551-9.
2. The Art of Service. (2021). Data and Analytics: A Complete Guide – 2021 Edition. The Art of Service, ISBN: 978-1-867-44389-6.

Web Links:

1. https://onlinecourses.nptel.ac.in/noc22_mg68/preview
2. <https://www.coursera.org/professional-certificates/google-data-analytics>

Relevant cases have to be discussed in each unit and in examination case study is compulsory from any unit.

DATA MINING & MACHINE LEARNING

Course Code: 2508MS28

L	T	P	C
2		1	3

Course Outcomes:

At the end of the Course, Student will be able to:

- CO1:** Explore the kinds of data that can be mined, major issues in data mining, and the societal impact of data mining.
- CO2:** Determine reasons for data preprocessing, major tasks involved, and techniques for data cleaning, reduction, transformation, and discretization.
- CO3:** Analyze the machine learning concepts, types of algorithms, and specific supervised learning algorithms.
- CO4:** Illustrate the user-based and item-based similarity in recommender systems, calculate cosine similarity, and address challenges with similarity measures.
- CO5:** Summarize the decision trees, building classifiers using gini criteria and entropy criteria. Measure test accuracy, display decision trees, find optimal criteria,

Mapping of Course Outcomes with Program Outcomes:

CO / PO	PO1	PO2	PO3	PO4	PO5	PO6	PO7	PO8
CO1	3	3	2	3	2	2	2	2
CO2	3	3	3	3	2	3	2	3
CO3	3	3	3	2	3	3	3	3
CO4	3	3	3	3	3	3	2	3
CO5	3	3	3	3	3	3	2	3

Mapping of Course Outcomes with Program Specific Outcomes:

CO / PSO	PSO1	PSO2	PSO3
CO1	3	2	2
CO2	3	3	3
CO3	3	3	3
CO4	3	3	3
CO5	3	3	3

UNIT – I

Introduction to Data Mining: Data Mining; Kinds of data that can be mined-Database Data, Data Warehouses, Transactional Data, Other Kinds of Data; Major Issues in Data Mining-Mining Methodology, User Interaction, Efficiency and Scalability, Diversity of Database Types, Data Mining and Society.

UNIT – II

Data Preprocessing: An Overview-Reasons to process the data, Major Tasks in Data Preprocessing; Data Cleaning-Missing Values, Noisy Data, Data Cleaning as a Process; Data Reduction-Principal Component Analysis, Histograms, Clustering, Sampling, Data Cube Aggregation; Data Transformation and Data Discretization-Data Transformation by Normalization, Discretization by Binning, Discretization by Histogram Analysis.

UNIT – III

Machine Learning: What is Machine Learning; Types of Machine Learning Algorithms- Supervised, Unsupervised and Reinforcement Learning. Supervised Learning-K Nearest Neighbors, Random Forest and Boosting

UNIT – IV

Recommender Systems Using Machine Learning: User Based Similarity-Calculating Cosine Similarity Between Users, Filtering Similar Users, Challenges with User Based Similarity. Item Based Similarity-Calculating Cosine Similarity between Movies, Finding Most Similar Movies. Matrix Factorization.

UNIT – V

Decision Tree Classification: Introduction to Decision Tree; Building Decision Tree Classifier using Gini Criteria; Measuring Test Accuracy; Displaying the Tree; Building Decision Tree Classifier using Entropy Criteria. Finding Optimal Criteria; Maximum Depth of the Tree and Benefits and Disadvantages of Decision Tree Case Study: Applying Decision Tree Classification on German Credit Data.

Text Books:

- 1 Han, J., Pei, J., & Kamber, M. (2022). Data mining: Concepts and techniques (4th ed.). Morgan Kaufmann, ISBN: 9780128181487.
- 2 Raschka, S., Mirjalili, V., & Mirjalili, S. (2022). Python machine learning: Machine learning and deep learning with Python, scikit-learn, and TensorFlow 2 (4th ed.). Packt Publishing, ISBN: 9781801819312.

Reference Books:

- 1 Aggarwal, C. C. (2021). Machine learning for data streams: with practical examples in MOA (2nd ed.). Springer, ISBN: 9783030664574
- 2 Géron, A. (2022). Hands-on machine learning with Scikit-Learn, Keras, and TensorFlow (3rd ed.). O'Reilly Media, ISBN: 9781098125974.

Web Links:

- 1 https://onlinecourses.nptel.ac.in/noc21_cs06/preview
- 2 <https://www.coursera.org/specializations/machine-learning-introduction>

Relevant cases have to be discussed in each unit and in examination case study is compulsory from any unit.

MAJOR 5: LOGISTICS AND SUPPLY CHAIN (LSM)

LOGISTICS MANAGEMENT

Course Code: 2508MS55	L	T	P	C
	2		1	3

Course Outcomes:

At the end of the Course, Student will be able to:

- CO1:** Analyse the interdependencies between logistics and other business functions (e.g., marketing, production, finance).
- CO2:** Explore the different logistical activities.
- CO3:** Identify the development of supply chain strategy
- CO4:** Examine the logistical operational integration and supply chain relationships
- CO5:** Assess the role of Supply Chain in e-business and b2b practices

Mapping of Course Outcomes with Program Outcomes:

CO / PO	PO1	PO2	PO3	PO4	PO5	PO6	PO7	PO8
CO1	3	2	2	2	3	2	2	2
CO2	3	3	2	2	2	3	3	2
CO3	3	2	2	3	3	3	3	2
CO4	3	3	2	3	2	2	3	2
CO5	3	3	2	3	3	3	3	3

Mapping of Course Outcomes with Program Specific Outcomes:

CO / PSO	PSO1	PSO2	PSO3
CO1	3	2	2
CO2	3	3	3
CO3	3	3	3
CO4	3	3	2
CO5	3	3	3

UNIT – I

Logistics Management and Supply Chain Management - Definition, Evolution, Importance. The concepts of logistics. Logistics relationships. Functional applications – HR, Marketing, Operations, Finance, IT. Logistics Organization - Logistics in different industries

UNIT – II

Logistics Activities: – functions, objectives, solution. Customer Service, Warehousing and Material Storage, Material Handling, order processing, information handling and procurement Transportation and Packaging. Third party and fourth party logistics - Reverse Logistics - Global Logistics

UNIT – III

Fundamentals of Supply Chain and Importance: Development of SCM concepts and Definitions Supply chain strategy, Strategic Supply Chain Management and Key components. Drivers of Supply Chain Performance – key decision areas – External Drivers of Change.

UNIT – IV

Modelling Logistics Systems - Simulation of logistic systems - Dimensions of Logistics & SCM – The Macro perspective and the macro dimension – Logistic system analysis strategy, Logistical Operations Integration, Customer service – Supply Chain Relationships

UNIT – V

Framework and Role of Supply Chain in E-business and B2B practices: Value of information in logistics & SCM - E-logistics, E-Supply Chains - International and global issues in logistics - Role of government in international logistics and Principal characteristics of logistics in various countries and regions

Text Books:

1. Supply Chain Logistics Management, Bowersox, Closs, Cooper, McGraw Hill. 5th Edition, (9th reprint), 2021, ISBN-0078096642
2. Christopher, M. (2021). Logistics & Supply Chain Management (6th ed.). Pearson, ISBN: 9781292545791.

Reference Books:

1. Rushton, A., Croucher, P., & Baker, P. (2021). The Handbook of Logistics and Distribution Management (7th ed.). Kogan Page. ISBN: 9780749498353
2. Mangan, J., Lalwani, C., & Lalwani, C. L. (2021). Global Logistics and Supply Chain Management (4th ed.). Wiley. ISBN: 9781119690157.

Web Links:

1. <https://archive.nptel.ac.in/courses/110/105/110105141/>
2. <https://www.youtube.com/watch?v=Nrl0CtS1m8Y>

Relevant cases have to be discussed in each unit and in examination case study is compulsory from any unit.

STORE KEEPING AND WAREHOUSING MANAGEMENT

Course Code: 2508MS79	L	T	P	C
	2		1	3

Course Outcomes:

At the end of the Course, Student will be able to:

- CO1:** Explain the aspects of store house operations.
- CO2:** Develop the layout of container terminals and equipment used in container terminals.
- CO3:** Discover the benefits and issues in logistics outsourcing
- CO4:** Prioritize the objectives of warehousing management and automation in warehouse operations
- CO5:** Analyze warehouse layout and design and understand sustainable warehousing practices

Mapping of Course Outcomes with Program Outcomes:

CO / PO	PO1	PO2	PO3	PO4	PO5	PO6	PO7	PO8
CO1	3	2	2	2	2	2	2	1
CO2	2	2	2	1	2	2	3	1
CO3	3	3	2	2	2	2	3	2
CO4	3	3	2	2	2	3	3	2
CO5	3	3	3	2	3	3	3	3

Mapping of Course Outcomes with Program Specific Outcomes:

CO / PSO	PSO1	PSO2	PSO3
CO1	3	2	2
CO2	2	3	2
CO3	3	3	3
CO4	3	3	2
CO5	3	3	3

UNIT – I

Storehouse Operations and Control: Introduction, Objectives, Store house Operations and its Objectives, Daily Activities of Stores, Organizing a Store, Store Location and Layout, Selecting appropriate storage system, Centralization, Decentralization and variety reduction of stores, Store Housekeeping, Stores Accounting.

UNIT – II

Infrastructure and Layout of Container Terminals: Infrastructure and layout of container terminals - Berth and quay characteristics- Apron width, quay crane rails - Container yard size, layout and markings - Container Freight Station (CFS) -Gates, offices, maintenance facilities, fencing and traffic control. Types and purpose of equipment used in container terminals - Ship to shore handling equipment - Yard equipment for transfer, storage and delivery - CFS and other terminal equipment Terminal automation

UNIT – III

Logistics Outsourcing: Introduction, Objectives, Concept of Logistics Outsourcing, Catalyst for logistics outsourcing, Benefits of logistics outsourcing, Issues in logistics outsourcing, Third-Party Logistics, Fourth-Party Logistics, Selection of Logistics Service Provider, Logistics Service Contract, Outsourcing- Value Proposition.

UNIT – IV

Warehousing Operations and Management: Objectives of warehousing management; Physical control and security; Automation and IT systems in warehouse operations and management.

UNIT – V

Warehouse Layout and Design: Warehouse layout and design, Optimal space utilization, workflow efficiency, and ergonomic design. Improving storehouse speed, space optimization, Sustainable Warehousing- Integrating green processes and eco-friendly materials. Reducing the industry's carbon footprint.

Text Books:

1. Gu, J., Goetschalckx, M., & McGinnis, L. F. (2021). Warehouse Management: A Complete Guide to Improving Efficiency and Minimizing Costs in the Modern Warehouse (2nd ed.). Kogan Page, ISBN: 9780749484967.
2. Rouwenhorst, B., Reuter, B., Stockrahm, V., van Houtum, G. J., Mantel, R. J., & Zijm, W. H. M. (2020). Warehouse & Distribution Science. Release 0.98 (Updated), ISBN: 9780983725112 (ebook)

Reference Books:

1. Tompkins, J. A., Smith, J. D., & Closs, D. J. (2021). The Warehouse Management Handbook (4th ed.). Wiley, ISBN: 9781119710910.
2. Bartholdi, J. J., & Hackman, S. T. (2021). Warehouse & Distribution Science: Release 1.0 (Revised). Supply Chain and Logistics Institute, ISBN: 9781732353029 (ebook).

Web Links:

1. <https://archive.nptel.ac.in/courses/110/105/110105095/>
2. <http://acl.digimat.in/nptel/courses/video/110105141/L29.html>

Relevant cases have to be discussed in each unit and in examination case study is compulsory from any unit.

TRANSPORTATION AND INFRASTRUCTURE MANAGEMENT FOR SCM

Course Code: 2508MS89	L	T	P	C
	2		1	3

Course Outcomes:

At the end of the Course, Student will be able to:

- CO1:** Identify the features of logistics transportation.
- CO2:** Interpret the features of railway logistics.
- CO3:** Examine the features, facilities and suitability of roadways
- CO4:** Explain the port operations and services.
- CO5:** Apply knowledge of air transport to develop efficient and effective air cargo operations.

Mapping of Course Outcomes with Program Outcomes:

CO / PO	PO1	PO2	PO3	PO4	PO5	PO6	PO7	PO8
CO1	3	2	2	2	2	1	3	1
CO2	3	2	1	1	1	1	3	1
CO3	3	2	2	1	1	1	3	1
CO4	3	2	2	2	1	2	3	2
CO5	3	2	2	2	2	2	3	2

Mapping of Course Outcomes with Program Specific Outcomes:

CO / PSO	PSO1	PSO2	PSO3
CO1	3	2	2
CO2	3	2	2
CO3	3	2	2
CO4	3	2	2
CO5	3	2	2

UNIT – I

Transportation and Logic: significance of transportation logistics: utility created by transportation in logistics transportation as a means of conquering time and space features of inbound, outbound, local and medium, long and continental transportation- features of logistics Transportation.

UNIT – II

Railway and Logistics Contours: Features and facilities offered by Railways Factors influencing growth in Rail Logistics- Suitability for different Cargo and distance Ranges segments – Innovative.

UNIT – III

Roadways and Logistics Contours: Roadways as primary and complementary modes in logistics, features, facilities, and suitability, innovations for logistics-friendly roads, factors influencing choice and growth in road logistics, suitability for different cargo and distance segments, innovative schemes for rail logistics in India, share of railways in cargo movement in India and globally, role of national and toll highways, outsourcing fleets, technology, cost, speed, security, dynamics, and competition with other modes.

UNIT – IV

Water Transport and Port Operations: Introduction to water transport, Main services, Services and facilities for ships -Administrative formalities - Cargo transfer - Services and facilities for cargo Berths and Terminals - Berth Facilities and Equipment -ship Operation – Pre shipment planning, the stowage plan and on-board stowage - cargo positioning and stowage on the terminal - Developments in cargo/container handling and terminal operation - Safety of cargo operations - Cargo security: Measuring and evaluating performance and productivity.

UNIT – V

Air Transport: Introduction to Air Transport – Air Freight – IATA –Cargo Handling at Goods at Air Port – Information Management of Air Cargo – System and Modules – Distribution of Goods.

Text Books:

1. Rushton, A., Croucher, P., & Baker, P. (2021). The Handbook of Logistics and Distribution Management (7th ed.). Kogan Page, ISBN: 9780749498353.
2. Mangan, J., Lalwani, C., & Lalwani, C. L. (2021). Global Logistics and Supply Chain Management (4th ed.). Wiley, ISBN: 9781119690157.

Reference Books:

1. Notteboom, T., & Rodrigue, J. P. (2022). Transportation and Logistics: The Supply Chain Imperative. Edward Elgar Publishing, ISBN: 9781803926360.
2. Liu, X., & Wang, Z. (2020). Infrastructure Management for Supply Chains: Concepts and Applications. Springer, ISBN: 9783030465432

Web Links:

1. <https://archive.nptel.ac.in/courses/110/106/110106045/>
2. <https://elearn.nptel.ac.in/shop/iit-workshops/completed/supply-chain-management/?v=c86ee0d9d7ed>

Relevant cases have to be discussed in each unit and in examination case study is compulsory from any unit.

PURCHASING AND MATERIAL MANAGEMENT

Course Code: 2508MS72	L	T	P	C
	2		1	3

Course Outcomes:

At the end of the Course, Student will be able to:

- CO1:** Apply the role of purchasing and materials planning in push and pull system.
- CO2:** Simplify pricing models, negotiation techniques, and cost analysis.
- CO3:** Analyze the purpose and significance of inventory within organizations.
- CO4:** Explore the objectives and types of materials handling.
- CO5:** Differentiate between packing and packaging.

Mapping of Course Outcomes with Program Outcomes:

CO / PO	PO1	PO2	PO3	PO4	PO5	PO6	PO7	PO8
CO1	3	2	2	2	1	1	3	2
CO2	3	2	3	2	1	1	2	1
CO3	3	3	2	2	1	1	2	1
CO4	3	2	2	1	1	2	2	2
CO5	2	1	2	1	1	1	2	1

Mapping of Course Outcomes with Program Specific Outcomes:

CO / PSO	PSO1	PSO2	PSO3
CO1	3	2	2
CO2	3	2	2
CO3	3	2	2
CO4	3	2	2
CO5	2	1	1

UNIT – I

Role of Purchasing and Materials Management- objectives, organization and Inter relationships, Determination and Description of material Quantity, Material planning in push and pull system, MRP and JIT.

UNIT – II

Purchase System and Procedures: - objectives, purchasing function, Purchasing policies and decisions, make or Buy vendor selection and Rating, Timing of purchase, price determination, purchase procedures and system public purchasing and tendering.

UNIT – III

Inventory Management – Introduction of inventory system, Function of Inventory and Relevant cost concept, classification of Inventory systems, Inventory Models: Deterministic Discount, EOQ EBQ, MRP – I, selective Inventory Management ABC, VED, FSN, PQR.

UNIT – IV

Materials Handling: Materials handling systems and objectives; Types of handling equipment; Selection of the most appropriate equipment in specific situations, Traffic and Transportation, Disposal of Scrap, waste management waste reduction approach, waste collection, Recycling waste disposal system, materials information system.

UNIT – V

Packing and Packaging: Meaning, Functions and Essentials of Packing- Packaging: Meaning, Functions and Essentials of Packaging- Difference between Packing and Packaging-Packing for Storage- Packing for Overseas Shipment- Packing for Inland Transportation- Packaging for Product content Protection - Test of packaging: Mechanical, Climatic & Lab test- International Care labelling code - Packaging cost.

Text Books:

1. Monczka, R. M., Handfield, R. B., Giunipero, L. C., & Patterson, J. L. (2021). Purchasing and Supply Chain Management (7th ed.). Cengage Learning.
2. Burt, D. N., Petcavage, S. D., & Pinkerton, R. L. (2021). Supply Chain Management: A Strategic Perspective (2nd ed.). Pearson Education, ISBN: 9780136017584.

Reference Books:

1. Kumar, S., & Singh, R. K. (2022). Sustainable Purchasing and Supply Chain Management. Springer.
2. Lysons, K., & Farrington, B. (2020). Purchasing and Supply Chain Management (10th ed.). Pearson. ISBN: 9781292216555

Web Links:

1. <https://archive.nptel.ac.in/courses/110/105/110105095/>
2. https://onlinecourses.nptel.ac.in/noc20_mg17/preview

Relevant cases have to be discussed in each unit and in examination case study is compulsory from any unit.

REVERSE LOGISTICS

Course Code: 2508MS73	L	T	P	C
	2		1	3

Course Outcomes:

At the end of the Course, Student will be able to:

- CO1:** Explain the differences between forward and reverse logistics
- CO2:** Develop the commercial reverse logistics in the field of apparel, aviation, retail, automotive, electronics, food, beverage and sporting goods
- CO3:** Analyze the importance of customer service returns and after service customer support as applied to reverse logistics
- CO4:** Assess how green buildings enhance energy efficiency, reduce environmental impact, and improve occupant well-being.
- CO5:** Estimate the influence of organizational culture on reverse logistics practices.

Mapping of Course Outcomes with Program Outcomes:

CO / PO	PO1	PO2	PO3	PO4	PO5	PO6	PO7	PO8
CO1	3	2	2	1	1	2	2	2
CO2	3	2	2	1	1	2	3	2
CO3	3	3	3	2	2	2	2	2
CO4	2	2	2	2	3	2	3	3
CO5	2	2	3	1	2	2	3	2

Mapping of Course Outcomes with Program Specific Outcomes:

CO / PSO	PSO1	PSO2	PSO3
CO1	3	2	2
CO2	3	2	2
CO3	3	2	2
CO4	2	2	3
CO5	2	2	3

UNIT – I

Reverse Logistics and Forward Logistics: Commercial logistics and the military, Measuring reverse logistics and improvement best practices of military reverse logistics, Management of complex systems and reverse logistics

UNIT – II

Reverse Logistics Principles: Successful management principles are successful reverse logistics principles, best practices in retail, apparel, electronics, food, beverage, and sporting goods

UNIT – III

Customer Service Returns: RMA and other elements of returns best practices in customer service and after sales customer support Reverse logistics concerns of the secondary market.

UNIT – IV

Green Reverse Logistics: Green reverse logistics practices green buildings that support logistics (LEED Certification) Successful global projects.

UNIT – V

Organizational Culture and Reverse Logistics: organizational culture and review how it applies to reverse logistics Review cultural design to support reverse logistics Reduction of risk in the reverse supply chain Securing the supply chain.

Text Books:

1. Saini, S. (2023). Introduction to reverse logistics. Independently published. ISBN: 9798389816464
2. Blokdyk, G. (2020). Reverse logistics: A complete guide – 2021 edition. 5STARCOoks. ISBN: 9781867438335

Reference Books:

1. Rogers, D. S., & Lembke, R. S. (2021). Reverse logistics. *In* International encyclopedia of transportation (Vol. 3, pp. 208–218). Elsevier. ISBN: 9780081026717
2. Bozzi, A., et al. (2022). Sustainable reverse logistics in fast fashion e-commerce. Chalmers University of Technology.

Web Links:

1. https://onlinecourses.nptel.ac.in/noc24_hs128/preview
2. https://ocw.mit.edu/courses/esd-s43-green-supply-chain-management-spring2014/resources/mitesd_s43s14_lecture4/

Relevant cases have to be discussed in each unit and in examination case study is compulsory from any unit.

SUPPLY CHAIN RISK MANAGEMENT

Course Code: 2508MS85	L	T	P	C
	2		1	3

Course Outcomes:

At the end of the Course, Student will be able to:

- CO1:** Identify and assess potential risks in a supply chain, including operational, financial, and reputational risks.
- CO2:** Design and implement a supply chain risk management framework that aligns with industry best practices
- CO3:** Assess the effects of natural disasters, pandemics, and climate change on supply chain operations.
- CO4:** Explain key risk management concepts, including risk assessment, mitigation, and transfer, with relevant examples.
- CO5:** Supply the key principles of designing a resilient supply chain, including flexibility, agility, and adaptability.

Mapping of Course Outcomes with Program Outcomes:

CO / PO	PO1	PO2	PO3	PO4	PO5	PO6	PO7	PO8
CO1	3	2	3	2	2	3	2	2
CO2	3	3	3	3	3	3	2	2
CO3	2	2	3	2	3	3	2	2
CO4	3	3	3	3	3	2	3	2
CO5	3	3	3	3	3	3	3	3

Mapping of Course Outcomes with Program Specific Outcomes:

CO / PSO	PSO1	PSO2	PSO3
CO1	3	2	3
CO2	3	3	3
CO3	3	2	3
CO4	3	3	3
CO5	3	3	3

UNIT – I

Introduction of Risks Management: Concept and Process, An Action-Based Framework for Supply Chain Risk, Identification of Operational Hazards, Risk Assessment and Valuation, Tactical Risk Decisions and Crisis Management, Strategic Risk Mitigation, Four Operational Hedging Strategies.

UNIT – II

Operational Strategy for Managing Supply Chain Risks: Introduction, Stockpile Inventory, Diversify Supply, Backup Supply, Manage Demand, Ambiguity in Risks. Decentralized Risks Management Strategy. Shared risks; Achieving an integrated approach; Identifying risks, Analyzing and responding to risks

UNIT – III

Managing Supply Chain Disruption: Economic Risks to Supply Chain-Demand Shock, Currency Fluctuation, Supply Shock, Industrial Unrest, Impacts of Natural Disasters, pandemics and Climate Change, Societal Risks to Supply chain, Risks and Security in Air Cargo Supply chain, Time-Based Risk Management-Response Time and Impacts, Risk and Reward Considerations.

UNIT – IV

Approaches to Risk Management: Identifying Risks and its Types, Tools for Analysing Past Events, Tools to Collect Opinions, Tools to Analyse Operations, Problems with Risks Identification, Conceptual Explanations with Examples, Development of Risk Management Techniques, Supply Chain Risk Management (SCRM) and aims of SCRM.

UNIT – V

Creating Resilient Supply Chains: Concept of Resilient Supply Chain, Principles of Designing a Resilient Supply Chain, Physical Features of a Resilient Supply Chain, relationships within a Resilient Supply Chain, Risk Compensation and Business Continuity. Latest updates in Resilient Supply Chain.

Text Books:

1. Helmold, M., Küçük Yılmaz, A., Dathe, T., & Flouris, T. G. (2022). Supply chain risk management: Cases and industry insights. Springer. ISBN: 9783030907990.
2. Lai, K. K., & Zhou, X. (2021). Risk management in supply chains: Using linear and non-linear models. Routledge. ISBN: 9781032089447

Reference Books:

1. Manners-Bell, J. (2023). Supply chain risk management: How to design and manage resilient supply chains. Kogan Page. ISBN: 9781398613232
2. The Art of Service. (2020). Supply chain risk management: A complete guide – 2021 edition. The Art of Service. ISBN: 9781867425083

Web Links:

1. http://ndl.iitkgp.ac.in/he_document/nptel/nptel/courses_110_108_110108056_video lec9
2. http://ndl.iitkgp.ac.in/he_document/nptel/courses_110_108_110108056_video lec11

Relevant cases have to be discussed in each unit and in examination case study is compulsory from any unit.

ENTERPRISE RESOURCE PLANNING

Course Code: 2508MS34	L	T	P	C
	2		1	3

Course Outcomes:

At the end of the Course, Student will be able to:

- CO1:** Make use of Enterprise software, and its role in integrating business function
- CO2:** Analyze the strategic options for ERP identification and adoption
- CO3:** Design the ERP implementation strategies.
- CO4:** Apply reengineering business processes for successful ERP implementation.
- CO5:** Summarize emerging trends in Enterprise Resource Planning

Mapping of Course Outcomes with Program Outcomes:

CO / PO	PO1	PO2	PO3	PO4	PO5	PO6	PO7	PO8
CO1	3	2	3	3	3	3	2	2
CO2	3	3	3	3	3	3	2	2
CO3	3	3	3	3	3	3	2	2
CO4	3	3	3	3	3	3	3	2
CO5	3	3	3	3	3	3	3	3

Mapping of Course Outcomes with Program Specific Outcomes:

CO / PSO	PSO1	PSO2	PSO3
CO1	3	3	3
CO2	3	3	3
CO3	3	3	3
CO4	3	3	3
CO5	3	3	3

UNIT – I

Introduction: Overview of enterprise systems – Evolution - Risks and benefits - Fundamental technology -Issues to be consider in planning design and implementation of cross functional integrated ERP systems

UNIT – II

ERP Solutions and Functional Modules: Overview of ERP software solutions- small, medium and large enterprise vendor solutions, BPR, and best business practices - Business process Management

UNIT – III

ERP Implementation: Planning Evaluation and selection of ERP systems - Implementation life cycle - ERP implementation, Methodology and Frame work- Data Migration. People Organization in implementation.

UNIT – IV

Post Implementation: Maintenance of ERP- Organizational and Industrial impact; Success and Failure factors of ERP Implementation.

UNIT – V

Emerging Trends on ERP: Extended ERP systems and ERP add-ons -CRM, SCM, Business analytics - Future trends in ERP systems

Text Books:

1. Arora, V. (2021). Enterprise resource planning. Random Publications. ISBN: 9789352697915.
2. Blokdyk, G. (2021). Enterprise resource planning: A complete guide – 2020 edition. 5STARCOOKS. ISBN: 9780655925460.

Reference Books:

1. Gronau, N. (2021). Enterprise resource planning: Architektur, Funktionen und Management von ERP-Systemen (4th ed.). De Gruyter. ISBN: 9783110662832
2. Elbardan, H., & Kholeif, A. O. (2017). Enterprise resource planning, corporate governance and internal auditing: An institutional perspective. Palgrave Macmillan. ISBN: 9783319549897

Web Links:

1. <https://www.coursera.org/learn/understanding-the-enterprise-systems-environment>
2. <https://www.coursera.org/learn/enterprise-systems>

Relevant cases have to be discussed in each unit and in examination case study is compulsory from any unit.

INTERNATIONAL LOGISTICS MANAGEMENT

Course Code: 2508MS48	L	T	P	C
	2		1	3

Course Outcomes:

At the end of the Course, Student will be able to:

- CO1:** Explain the concept of logistics integration and barriers to integration.
- CO2:** Identify the international marketing and channels and modes of transport.
- CO3:** Develop the multimodal transport characteristics and tariff structures.
- CO4:** Assess the benefits and constraints of containerization and chartering countainerization
- CO5:** Prepare and manage customs documentation, including commercial invoices, bills of lading, and certificates of origin.

Mapping of Course Outcomes with Program Outcomes:

CO / PO	PO1	PO2	PO3	PO4	PO5	PO6	PO7	PO8
CO1	3	2	3	3	3	3	2	2
CO2	3	3	3	3	3	3	2	2
CO3	3	3	3	3	3	3	2	2
CO4	3	3	3	3	3	3	3	2
CO5	3	3	3	3	3	3	3	3

Mapping of Course Outcomes with Program Specific Outcomes:

CO / PSO	PSO1	PSO2	PSO3
CO1	3	3	3
CO2	3	3	3
CO3	3	3	3
CO4	3	3	3
CO5	3	3	3

UNIT – I

Overview Logistics: Definition, Evolution, Concept, Components, Importance, Objectives; Logistic Subsystem; The work of Logistics; Integrated Logistics; Barrier to Internal Integration.

UNIT – II

Marketing and Logistics: Customer Focused Marketing; International Marketing: Introduction, Definition, Basis for International Trade, Process, Importance; International Marketing Channel: Role of Clearing Agent, Various Modes of Transport, Choice and Issues for Each Mode, Transport Cost Characteristics

UNIT – III

Basics of Transportation- Transportation functionality and Principles; Multimodal Transport: Modal Characteristics; Modal Comparisons; Legal Classifications; International Air Transport; Air Cargo Tariff Structure; Freight: Definition, Rate; Freight Structure and Practice

UNIT – IV

Containerization and Chartering Containerization: Genesis, Concept, Classification, Benefits and Constraints; Inland Container Depot (ICD): Roles and Functions, CFS, Export Clearance at ICD; CONCOR; ICDs under CONCOR; Chartering: Kinds of Charter, Charter Party, and Arbitration.

UNIT – V

Special Aspects of Export logistics: Picking, Packing, Vessel Booking [Less-than Container Load (LCL) / Full Container Load (FCL)], Customs, Documentation, Shipment, Delivery to distribution centres, distributors and lastly the retail outlets- Import Logistics: Documents Collection- Valuing- Bonded Warehousing- Customs Formalities

Text Books:

1. David, P. A. (2021). International logistics: The management of international trade operations (6th ed.). Cicero Books, LLC. ISBN: 9781736945605
2. Ellram, L. M., Fawcett, S. E., Goldsby, T. M., Hofer, C., & Rogers, D. (2024). Logistics management: Enhancing competitiveness and customer value. MyEducator.com. ISBN: 9781951693459

Reference Books:

1. Sheffi, Y. (2023). The magic conveyor belt: Supply chains, AI, and the future of work. CTL Media. ISBN: 9781735766140
2. Lehmacher, W. (2023). Maritime decarbonization: Practical tools, case studies and decarbonization enablers. Springer Gabler. ISBN: 9783658391232.

Web Links:

1. <https://www.vskills.in/certification/certified-international-logistics-management-professional-course-outline>
2. <https://archive.nptel.ac.in/courses/110/108/110108056/>

Relevant cases have to be discussed in each unit and in examination case study is compulsory from any unit.

**MAJOR 6: DIGITAL TRANSFORMATION AND INNOVATION (DTI)
DATA MINING FOR BUSINESS DECISIONS**

Course Code: 2508MS27

L	T	P	C
2		1	3

Course Outcomes:

At the end of the Course, Student will be able to:

- CO1:** Explain the fundamental concepts and principles of data mining and its applications.
- CO2:** Differentiate between Business Intelligence and Data Mining.
- CO3:** Identify and interpret clustering results using appropriate metrics and visualization techniques.
- CO4:** Analyze the principles and techniques of Web Mining, including web content mining, web structure mining, and web usage mining.
- CO5:** Determine the importance of data mining in transforming raw data into actionable knowledge.

Mapping of Course Outcomes with Program Outcomes:

CO / PO	PO1	PO2	PO3	PO4	PO5	PO6	PO7	PO8
CO1	3	3	3	3	3	2	3	2
CO2	3	3	3	2	3	3	3	2
CO3	3	3	3	3	3	3	2	3
CO4	3	3	3	3	3	2	2	3
CO5	3	3	3	3	3	3	3	3

Mapping of Course Outcomes with Program Specific Outcomes:

CO / PSO	PSO1	PSO2	PSO3
CO1	3	3	3
CO2	3	3	3
CO3	3	3	3
CO4	3	3	3
CO5	3	3	3

UNIT – I

Introduction to Data Mining: Introduction-- Scope of Data Mining-- What is Data Mining-- How does Data Mining Works-- Predictive Modelling-- Data Mining and Data Warehousing-- Architecture for Data Mining: Profitable Applications-- Data Mining Tools:

UNIT – II

Business Intelligence: Introduction, Business Intelligence-- Business Intelligence tools-- Business Intelligence Infrastructure-- Business Intelligence Applications-- BI versus Data Warehouse--BI versus Data Mining-- Future of BI. Data Preprocessing: Introduction-- Data Preprocessing Overview-- Data Cleaning-- Data Integration and Transformation-- Data Reduction-- Discretization and Concept Hierarchy Generation.

UNIT – III

Data Mining Techniques an Overview: Introduction-- Data Mining-- Data Mining Versus Database Management System-- Data Mining Techniques- Association rules— Classification— Regression— Clustering-- Neural networks. Clustering—Introduction— Clustering-- Cluster Analysis-- Clustering

Methods- K means-- Hierarchical clustering-- Agglomerative clustering-- Divisive clustering-- clustering and segmentation software-- evaluating clusters.

UNIT – IV

Web Mining: Introduction—Terminologies-- Categories of Web Mining – Web Content Mining-
- Web Structure Mining-- Web Usage Mining-- Applications of Web Mining and Agent based and Data base approaches-- Web mining Software.

UNIT – V

Applications of Data Mining: Introduction-- Business Applications Using Data Mining Risk management and targeted marketing-- Customer profiles and feature construction-- Medical applications (diabetic screening) -- Scientific Applications using Data Mining-- Other Applications.

Text Books:

1. Shmueli, G., Bruce, P. C., Gedeck, P., & Patel, N. R. (2020). Data mining for business analytics: Concepts, techniques, and applications in Python. Wiley, ISBN: 9781119549840
2. Bramer, M. (2020). Principles of data mining (3rd ed.). Springer. ISBN: 9781447173069.

Reference Books:

1. Cao, L., Yu, P. S., Zhang, C., & Zhang, H. (Eds.). (2009). Data mining for business applications. Springer. ISBN: 9780387794198.
2. Soares, C., & Ghani, R. (Eds.). (2010). Data mining for business applications. IOS Press. ISBN: 9781607506324.

Web Links:

1. https://onlinecourses.nptel.ac.in/noc21_cs06/preview
2. <https://ggsestc.digimat.in/nptel/courses/video/110105089/L39.html>

Relevant cases have to be discussed in each unit and in examination case study is compulsory from any unit.

MANAGING SOFTWARE PROJECTS

Course Code: 2508MS61	L	T	P	C
	2		1	3

Course Outcomes:

At the end of the Course, Student will be able to:

- CO1:** Demonstrate Leadership skills, including stakeholder management communication and conflict resolution, essential for project success
- CO2:** Apply cost estimation, resource allocation, and budgeting techniques to manage project finances effectively.
- CO3:** Conduct qualitative and quantitative risk analysis to evaluate the likelihood and impact of risks on project objectives.
- CO4:** Navigate legal and regulatory frameworks governing procurement contracting and outsourcing activities.
- CO5:** Develop leadership qualities necessary for guiding and motivating project teams toward achieving project objectives.

Mapping of Course Outcomes with Program Outcomes:

CO / PO	PO1	PO2	PO3	PO4	PO5	PO6	PO7	PO8
CO1	3	3	2	3	3	3	3	3
CO2	3	3	3	2	3	3	3	3
CO3	3	3	3	3	3	3	2	3
CO4	3	3	3	3	3	2	2	3
CO5	3	3	2	3	3	3	3	3

Mapping of Course Outcomes with Program Specific Outcomes:

CO / PSO	PSO1	PSO2	PSO3
CO1	3	3	3
CO2	3	3	3
CO3	3	3	3
CO4	3	3	3
CO5	3	3	3

UNIT – I

Introduction: What is project, what is project Management -The role of project Manager, the project Management Profession, Project life cycle - A system view of project management - Understanding organizations, Stakeholder management - Project phases and the project life cycle -The context of information technology projects.

UNIT – II

Developing the Project Schedule: Project management software tools-Developing the project budget, Finalizing the project schedule and budget -Monitoring and controlling the project -The project communications plan -Project metrics- Reporting performance and progress - Information distribution.

UNIT – III

Risk Management Planning: Common sources of risk on information technology projects, Risk identification, Qualitative risk analysis - Quantitative risk analysis, Risk response planning-Risk monitoring and control, using software to assist in project risk management.

UNIT – IV

Planning Purchase and Acquisitions: Planning contracting, requesting seller responses Selecting sellers, Administering the contract- Closing the contract - Using software to assist in project management – Outsourcing

UNIT – V

Project Leadership: Ethics in projects -Multicultural projects- Project implementation, administrative closure - Project evaluation

Text Books:

1. Meredith, J. R., Shafer, S. M., & Mantel, S. J. Jr. (2021). Project management: A managerial approach (11th ed.). Wiley. ISBN: 9781119803836
2. Larson, E. W., Gray, C. F., & Sirisomboonsuk, P. (2024). Project management: A socio-technical approach (8th ed.). McGraw Hill Education. ISBN: 9781265060886.

Reference Books:

1. Project Management Institute. (2021). A guide to the project management body of knowledge (PMBOK® guide) (7th ed.). Project Management Institute. ISBN: 9781628256642
2. Ika, L. A. (2023). Managing fuzzy projects in 3D: A proven, multi-faceted blueprint for overseeing complex projects. McGraw Hill Education. ISBN: 9781264278343

Web Links:

1. <http://www.digimat.in/nptel/courses/video/106105218/L01.html>
2. https://onlinecourses.nptel.ac.in/noc19_cs70/preview

Relevant cases have to be discussed in each unit and in examination case study is compulsory from any unit.

WEB DESIGNING

Course Code: 2508MS91

L	T	P	C
2		1	3

Course Outcomes:

At the end of the Course, Student will be able to:

- CO1:** Explain the history and evolution of the web and its underlying technologies.
- CO2:** Develop the HTTP message format and differentiate between persistent and non-persistent connections.
- CO3:** Construct web pages using HTML, including text, lists, links, images, tables, forms, frames, and meta tags.
- CO4:** Design and develop visually appealing web pages using CSS layout techniques.
- CO5:** Apply advanced JavaScript techniques, such as event handling and DOM manipulation.

Mapping of Course Outcomes with Program Outcomes:

CO / PO	PO1	PO2	PO3	PO4	PO5	PO6	PO7	PO8
CO1	3	3	2	2	2	2	2	2
CO2	2	3	3	2	2	3	2	2
CO3	3	3	3	3	3	3	2	3
CO4	3	3	3	3	3	3	2	3
CO5	3	3	3	3	3	3	2	3

Mapping of Course Outcomes with Program Specific Outcomes:

CO / PSO	PSO1	PSO2	PSO3
CO1	3	3	2
CO2	3	3	3
CO3	3	3	3
CO4	3	3	3
CO5	3	3	3

UNIT – I

Web Fundamentals: Introduction To the Web, History of the Web, Protocols Governing the Web, Creating Websites for Individuals and the Corporate World, Web Applications, Writing Web Projects, Identification of Objects, Target User, Web Team, Planning and Process Development, Web Architecture, Major Issues in the Web Solutions Development, Web Servers (Apache Web Server), Web Browsers, Internet Standards, TCP/IP Protocol Suite, IP Addresses, MIME, Cyber Laws.

UNIT – II

Hyper Text Transfer Protocol (HTTP): Introduction - Web Server and Clients, Resources, URL and its Anatomy – Examples, Message Format, Persistent and Non-Persistent Connections, Web Caching, Proxy. Java Network Programming- Java and the Net, Java Networking Classes and Interfaces, Looking up Internet Address, Client/Server Programs, Socket Programming, E-mail Client. (lab sessions to be conducted)

UNIT – III

Hyper Text Markup Language (HTML): Introduction, Structure, Text, Lists, Links, Images, Tables, Forms, Frames, Images, and Meta Tags. (lab sessions to be conducted).

UNIT – IV

Cascading Style Sheets (CSS): Introduction, Advantages, Color, Text, Boxes, Lists, Tables and Forms, Layout, Images, HTML5 Layout. (Lab Sessions to be conducted)

UNIT – V

JavaScript: Introduction, Variables, Literals, Operators, Control Structure, Conditional Statements, Arrays, Functions, Objects, JavaScript and HTML DOM, Advanced JavaScript and HTML Forms (Lab sessions to be conducted).

Text Books:

1. Felke-Morris, T. A. (2021). Basics of Web Design: HTML5 & CSS (6th ed.). Pearson. ISBN: 9780137313211.
2. Osborn, T. (2021). Hello Web Design: Design Fundamentals and Shortcuts for Non-Designers. No Starch Press. ISBN: 9781718501386

Reference Books:

1. Frain, B. (2022). Responsive Web Design with HTML5 and CSS (4th ed.). Packt Publishing. ISBN: 9781803242712.
2. Minnick, D. (2021). Responsive Web Design with HTML5 & CSS (9th ed.). Cengage Learning. ISBN: 9780357423837

Web Links:

- 1 <https://nptel.ac.in/courses/106106222>
- 2 <https://nptel.ac.in/courses/106106156>

Relevant cases have to be discussed in each unit and in examination case study is compulsory from any unit.

BUSINESS ANALYTICS

	L	T	P	C
Course Code: 2508MS11	2		1	3

Course Outcomes:

At the end of the Course, Student will be able to:

- CO1:** Trace the historical development of business analytics from its origins to the present day.
- CO2:** Demonstrate proficiency in using Excel for data manipulation, formula application, and data queries.
- CO3:** Formulate and solve linear optimization models using spreadsheet software.
- CO4:** Analyze market data using frameworks like PESTLE and Porter's Five Forces to gain strategic insights.
- CO5:** Implement strategies for effective Master Data Management to ensure data consistency and accuracy across organizations.

Mapping of Course Outcomes with Program Outcomes:

CO / PO	PO1	PO2	PO3	PO4	PO5	PO6	PO7	PO8
CO1	3	2	3	2	2	3	2	2
CO2	3	3	3	2	2	3	2	2
CO3	3	3	3	3	3	3	3	3
CO4	3	3	3	3	3	3	2	3
CO5	3	3	3	2	3	3	2	2

Mapping of Course Outcomes with Program Specific Outcomes:

CO / PSO	PSO1	PSO2	PSO3
CO1	3	3	2
CO2	3	3	3
CO3	3	3	3
CO4	3	3	3
CO5	3	3	3

UNIT – I

Introduction to Business Analytics: Evolution of Business analytics, scope, Data for Business Analytics, Models in Business Analytics, problem solving with business analytics- Types of data, Integrating Analytics with business, Business Analytics for Competitive Advantage, Descriptive, Predictive, and Prescriptive Analytics, Dashboards Business Analytics Process Cycle.

UNIT – II

Analytics on Spreadsheets: Basic Excel, Excel formulas, Excel functions, data queries.
Descriptive Analytics: Descriptive statistical measures, populations and samples, statistical notations, measures of location, dispersion, and association. **Statistical Inference:** Hypothesis testing, one-sample test, two-sample test, two-tailed hypothesis for mean, ANOVA. **Predictive Analytics:** Simple linear regression, multiple linear regression, residual analysis, building regression models, regression with categorical independent variables.

UNIT – III

Machine Learning: Supervised Learning and Unsupervised Learning, Clustering & Segmentation, Affinity/ Association Analysis, Data Reduction, Visual Analytics and Data Visualization Prescriptive Analytics: Building Linear Optimization models, Implementing Linear Optimization models on spreadsheets, Solving Linear Optimization models.

UNIT – IV

Marketing Analytics: Models and metrics- Market Insight – Market data sources, sizing, PESTLE trend analysis, and porter five forces analysis - Market basket Analysis, Text Analytics, Spreadsheet Modeling - Sales Analytics: E Commerce sales mode, sales metrics, profitability metrics and support metrics.

UNIT – V

Introduction to Big Data: Master Data Management. Data Mining on what kind of data, what kinds of patterns can be mined, Which technologies are used, Which kinds of applications are targeted, Major issues in Data Mining. Getting to know your Data: Data Objects and Attribute Types, Basic Statistical Descriptions of Data, Data Visualization, Measuring data Similarity and Dissimilarity.

Text Books:

1. Camm, J. D., Cochran, J. J., Fry, M. J., & Ohlmann, J. W. (2021). Business analytics (4th ed.). Cengage Learning. ISBN: 9780357708385.
2. Jaggia, S., Kelly, A., Lertwachara, K., & Chen, L. (2025). Business analytics (2nd ed.). McGraw Hill Education. ISBN: 9781264302802.

Reference Books:

1. Blokdyk, G. (2021). Business analytics: A complete guide – 2021 edition. 5STARCOOKS. ISBN: 9781867428763
2. Nabavi, M., Olson, D. L., & Boyce, W. S. (2021). Introduction to business analytics (2nd ed.). Business Expert Press. ISBN: 9781953349699

Web Links:

1. <https://hbr.org/2020/01/what-is-business-analytics>
2. https://onlinecourses.nptel.ac.in/noc24_cs65/preview

Relevant cases have to be discussed in each unit and in examination case study is compulsory from any unit.

MANAGING DIGITAL INNOVATION AND TRANSFORMATION

Course Code: 2508MS60

L	T	P	C
2		1	3

Course Outcomes:

At the end of the Course, Student will be able to:

- CO1:** Explain the concept of digital transformation and its importance in today's business environment.
- CO2:** Examine the requirements for social media transformation.
- CO3:** Identify and address challenges associated with building digital capabilities.
- CO4:** Analyze the need for re-organization to bridge the gap to digital customers.
- CO5:** Assess the impact of digital transformation on enterprise innovation.

Mapping of Course Outcomes with Program Outcomes:

CO / PO	PO1	PO2	PO3	PO4	PO5	PO6	PO7	PO8
CO1	3	3	3	3	3	3	2	3
CO2	3	2	3	3	3	3	2	2
CO3	3	3	3	3	3	3	3	3
CO4	3	2	3	3	3	3	3	3
CO5	3	3	3	3	3	3	2	3

Mapping of Course Outcomes with Program Specific Outcomes:

CO / PSO	PSO1	PSO2	PSO3
CO1	3	3	3
CO2	3	3	2
CO3	3	3	3
CO4	3	3	3
CO5	3	3	3

UNIT – I

Introduction to Digital Transformations: The five domains of digital transformations — customer, competition, data, innovation, and value, 1-farness customer networks, turn data into assets, adapt value proposition

UNIT – II

Classification of Digital Transformations: Business Model, product development, data, processes, knowledge, self—service, and organizational culture; Social Media Transformation: understand requirements, document goals, objective and social media tactics, establish potential future state operating model, gap analysis and recommendations.

UNIT – III

Building Digital Capabilities: challenges ongoing digital, handling employee during digital transformations, developing companywide strategy; Digital transformations in the space of cloud computing: prepare and drive digital transformations.

UNIT – IV

Digitalization of Professional Services: Re-Organization in Order to Bridge the Gap to Digital Customers - Value Creation in Virtual Law Firms - Digital Transformation Supporting Public Service Innovation: Business Model Challenges and Sustainable - Development Opportunities

UNIT – V

Areas of IT Management and its Challenges: IT services, IT organization - Enterprise Innovation and the Digital Transformation - Industry, development trends, business competitiveness due to Technology - Using Technology as Innovation, Integration and Interconnection of business - IT strategy, IT governance, IT sourcing and controlling

Text Books:

1. Hinterhuber, A., Vescovi, T., & Checchinato, F. (2021). Managing digital transformation: Understanding the strategic process. Routledge. ISBN: 9780367441975
2. Wittenstein, D. (2021). Managing digital transformation: Measuring firm-level digitalization. Springer. ISBN: 9783658366940.

Reference Books:

1. Badar, M. S., Gupta, H., Srivastava, S., Ali, M., & Cudney, E. A. (Eds.). (2023). Handbook of digital innovation, transformation, and sustainable development in a post-pandemic era. Routledge. ISBN: 9781032566887
2. Schallmo, D. R. A., Baiyere, A., Gertsen, F., Rosenstand, C. A., & Williams, C. A. (Eds.). (2024). Digital disruption and transformation: Case studies, approaches, and tools. Springer. ISBN: 9783031478888.

Web Links:

1. https://onlinecourses.nptel.ac.in/noc24_mg74/preview
2. https://onlinecourses.swayam2.ac.in/imb23_mg69/preview

Relevant cases have to be discussed in each unit and in examination case study is compulsory from any unit.

BIG DATA ANALYTICS

Course Code: 2508MS08

L	T	P	C
2		1	3

Course Outcomes:

At the end of the Course, Student will be able to:

- CO1:** Explain the importance of Big Data and SQL databases with Hadoop.
- CO2:** Simplify how HDFS ensures data reliability and availability.
- CO3:** Relate Hive with traditional RDBMS systems and understand the differences.
- CO4:** Compare H Base with traditional RDBMS systems and understand when to use HBase.
- CO5:** Solve common graph-related problems using Map Reduce.

Mapping of Course Outcomes with Program Outcomes:

CO / PO	PO1	PO2	PO3	PO4	PO5	PO6	PO7	PO8
CO1	3	3	2	3	3	3	2	3
CO2	3	3	2	3	3	3	2	3
CO3	3	3	2	3	3	3	3	3
CO4	3	3	2	3	3	3	3	3
CO5	3	3	3	3	3	3	3	3

Mapping of Course Outcomes with Program Specific Outcomes:

CO / PSO	PSO1	PSO2	PSO3
CO1	3	3	3
CO2	3	3	3
CO3	3	3	3
CO4	3	3	3
CO5	3	3	3

UNIT – I

Introduction to Big Data: Definition, characteristics (Volume, Variety, Velocity, Veracity, Validity), importance, patterns for development, data in warehouse vs Hadoop.

Introduction to Hadoop: Definition, distributed systems, comparing SQL databases with Hadoop, understanding MapReduce, running a basic program, Hadoop history, components: Name Node, Data Node, Secondary Name Node, Job Tracker, Task Tracker.

UNIT – II

HDFS: Components of Hadoop -Working with files in HDFS, Anatomy of a Map Reduce program, Reading and writing the Hadoop Distributed File system -The Design of HDFS, HDFS Concepts, The Command-Line Interface, Hadoop File system, The Java Interface, Data Flow, Parallel Copying with distcp, Hadoop Archives. Hadoop I/O: Compression— Serialization-- Avro and File-Based Data structures.

UNIT – III

Map Reduce Programming: Writing basic Map Reduce programs - Getting the patent data set, constructing the basic template of a Map Reduce program, counting things, adapting for

Hadoop's API changes, Streaming in Hadoop. Map Reduce Advanced Programming: Advanced Map Reduce - Chaining Map Reduce jobs, joining data from different sources.

UNIT – IV

Hadoop Eco System: User Defined Functions-- Data Processing operators. Hive: Hive Shell- - Hive Services-- Hive Meta store-- Comparison with Traditional Databases—HiveQL-- Tables, Querying Data and User Defined Functions. HBase: H Basics—Concepts—Clients— Example— Hbase Versus RDBMS. Big SQL: Introduction

UNIT – V

Graph Representation in Map Reduce: Modeling data and solving problems with graphs, Shortest Path Algorithm, Friends-of-Friends Algorithm, PageRank Algorithm, Bloom Filters. Data Analytics with R Machine Learning: Introduction, Supervised Learning, Unsupervised Learning, Collaborative Filtering. Big Data Analytics with BigR.

Text Books:

1. Demirbaga, Ü., Aujla, G. S., Jindal, A., & Kalyon, O. (2024). Big data analytics: Theory, techniques, platforms, and applications. Springer. ISBN: 978-3-031-55638-8.
2. Asllani, A. (2021). Big data technologies for business. Prospect Press. ISBN: 978-1943153901

Reference Books:

1. Pani, S. K., Tripathy, S., Jandieri, G., Kundu, S., & Butt, T. A. (Eds.). (2021). Applications of machine learning in big-data analytics and cloud computing. River Publishers. ISBN: 978-8770221825
2. Mawby, W. D. (2021). Navigating big data analytics. ASQ Quality Press. ISBN: 978-1951058159

Web Links:

1. <https://archive.nptel.ac.in/courses/106/104/106104189/>
2. https://onlinecourses.nptel.ac.in/noc20_cs92/preview

Relevant cases have to be discussed in each unit and in examination case study is compulsory from any unit.

CYBER LAWS & SECURITY

Course Code: 2508MS25

L	T	P	C
2		1	3

Course Outcomes:

At the end of the Course, Student will be able to:

- CO1:** Explain the meaning and concepts of cyber security.
- CO2:** Identify the importance of Secure System Planning and administration
- CO3:** Distinguish Information security policies and procedures in organization.
- CO4:** Compare and contrast the practical applications of Information security systems.
- CO5:** Conduct survey on Organizational and Human Security.

Mapping of Course Outcomes with Program Outcomes:

CO / PO	PO1	PO2	PO3	PO4	PO5	PO6	PO7	PO8
CO1	3	3	2	3	3	2	2	3
CO2	3	3	3	3	3	2	2	3
CO3	3	3	3	3	3	3	2	3
CO4	3	3	3	3	3	3	3	3
CO5	3	3	2	3	3	2	3	3

Mapping of Course Outcomes with Program Specific Outcomes:

CO / PSO	PSO1	PSO2	PSO3
CO1	3	3	2
CO2	3	3	3
CO3	3	3	3
CO4	3	3	3
CO5	3	2	3

UNIT – I

Introduction to Computer Security: Definition, Threats to security, Government requirements, Information Protection and Access Controls, Computer security efforts, Standards, Computer Security mandates and legislation, Privacy considerations, international security activity.

UNIT – II

Secure System Planning and Administration: Introduction to the orange book, Security policy requirements, accountability, assurance and documentation requirements, Network Security, The Red book and Government network evaluations.

UNIT – III

Information Security Policies and Procedures: Corporate policies- Tier 1, Tier 2 and Tier3 policies - process management-planning and preparation-developing policies-asset classification policy-developing standards.

UNIT – IV

Information Security: fundamentals-Employee responsibilities- information classification Information handling- Tools of information security- Information processing-secure program administration.

UNIT – V

Organizational and Human Security: Adoption of Information Security Management Standards, Human Factors in Security- Role of information security professionals.

Text Books:

1. Seth, K. (2021). Computers, Internet and New Technology Laws (3rd ed.). LexisNexis. ISBN: 9789391211437.
2. Duggal, P. (2023). Cyber Law (3rd ed.). LexisNexis. ISBN: 9789391211437.

Reference Books:

1. Information Resources Management Association. (2021). Cyber Law, Privacy, and Security: Concepts, Methodologies, Tools, and Applications (Vol. 1). IGI Global. ISBN: 9781668431139.
2. Dewani, N. D. (2021). Handbook of Research on Cyber Law, Data Protection, and Privacy. IGI Global. ISBN: 9781799886440

Web Links:

1. <http://acl.digimat.in/nptel/courses/video/106106248/L14.html>
2. https://onlinecourses.swayam2.ac.in/nou19_cs08/preview

Relevant cases have to be discussed in each unit and in examination case study is compulsory from any unit.

INFORMATION SYSTEMS AUDIT

Course Code: 2508MS44	L	T	P	C
	2		1	3

Course Outcomes:

At the end of the Course, Student will be able to:

- CO1:** Explain the meaning and concepts of Information System Auditing.
- CO2:** Analyze the importance of Management Control Framework.
- CO3:** Distinguish Management Control Framework for establishing effective controls.
- CO4:** Compare and contrast Evidence Evaluation systems.
- CO5:** Justify corporate governance issues in Indian context.

Mapping of Course Outcomes with Program Outcomes:

CO / PO	PO1	PO2	PO3	PO4	PO5	PO6	PO7	PO8
CO1	3	3	2	3	3	2	2	3
CO2	3	3	3	3	3	2	2	3
CO3	3	3	3	3	3	3	2	3
CO4	3	3	3	3	3	3	3	3
CO5	3	3	2	3	3	2	3	3

Mapping of Course Outcomes with Program Specific Outcomes:

CO / PSO	PSO1	PSO2	PSO3
CO1	3	3	2
CO2	3	3	3
CO3	3	3	3
CO4	3	3	3
CO5	3	2	3

UNIT – I

Overview of Information System Auditing: Effect of Computers on Internal Controls, Effects of Computers on Auditing, Foundations of information Systems Auditing, Conducting an Information Systems Audit.

UNIT – II

The Management Control Framework-I: Introduction, Evaluation the Planning Function, Leading Function and Controlling Function, Systems Development - Management Controls, Approaches to Auditing Systems Development, Normative Models of the Systems Development Process, Evaluating the Major phases in the Systems Development Process, Programming Management Controls, Data Resource Management Controls.

UNIT – III

The Management Control Framework-II: Security Management Controls, Operations Management Controls Quality Assurance Management Controls- Case Studies.

UNIT – IV

Evidence Collection: Audit Software, Code Review, Test Data, and Code Comparison, Concurrent Auditing techniques, Interviews, Questionnaires, and Control Flowcharts. Performance Management tools-Case Studies.

UNIT – V

Evidence Evaluation: Evaluating Asset Safeguarding and Data Integrity, Evaluating System Effectiveness, Evaluating System Efficiency. Information Systems Audit and Management: Managing the Information Systems Audit Function,

Text Books:

1. Louwers, T. J., Ramsay, R. J., Sinason, D. H., Strawser, J. R., & Thibodeau, J. C. (2021). Auditing & assurance services (8th ed.). McGraw Hill Education. ISBN: 9781260369205
2. Doshi, H. (2020). CISA – Certified Information Systems Auditor study guide: Aligned with the CISA review manual 2019 to help you audit, monitor, and assess information systems. Packt Publishing. ISBN: 9781838989583.

Reference Books:

1. Blokdyk, G. (2021). Information systems audit: A complete guide – 2021 edition. 5STARCOoks. ISBN: 9781867313007.
2. Doshi, H. (2020). CISA – Certified Information Systems Auditor study guide: Aligned with the CISA review manual 2019 to help you audit, monitor, and assess information systems. Packt Publishing. ISBN: 9781838989583

Web Links:

1. <https://archive.nptel.ac.in/noc/courses/noc15/SEM1/noc15-cs03/>
2. <https://www.coursera.org/learn/information-systems-audit/reviews?page=9>

Relevant cases have to be discussed in each unit and in examination case study is compulsory from any unit.

MAJOR 7: DIGITAL MARKETING (DM)

DIGITAL STARTUP AND NEW VENTURE MANAGEMENT

Course Code: 2508MS32	L	T	P	C
	2		1	3

Course Outcomes:

At the end of the Course, Student will be able to:

- CO1:** Identify various types of digital startups.
- CO2:** Estimate the capital and resource requirements for digital startups.
- CO3:** Examine the financial feasibility of digital startups.
- CO4:** Analyze the stages of growth for new ventures.
- CO5:** Develop strategies for dealing with failure.

Mapping of Course Outcomes with Program Outcomes:

CO / PO	PO1	PO2	PO3	PO4	PO5	PO6	PO7	PO8
CO1	3	2	3	2	3	2	3	3
CO2	3	3	2	3	3	3	3	3
CO3	3	3	3	3	3	2	3	3
CO4	3	3	3	3	3	3	3	3
CO5	3	3	2	3	3	3	3	3

Mapping of Course Outcomes with Program Specific Outcomes:

CO / PSO	PSO1	PSO2	PSO3
CO1	3	2	3
CO2	3	3	3
CO3	3	3	3
CO4	3	3	3
CO5	3	3	3

UNIT – I

Introduction to Digital Startup: Definition and types of startups-Digital startup ecosystem-The startup lifecycle-Identifying opportunities and ideation techniques-Role of innovation in digital startups-Case studies of successful digital startups

UNIT – II

Startup Capital Requirements and Legal Environment: Identifying Startup capital Resource requirements - estimating Startup cash requirements - Develop financial assumptions, constructing a Process Map - Positioning the venture in the value chain - Launch strategy to reduce risks- Startup financing metrics - The Legal Environment- Approval for New Venture Taxes or duties payable for new ventures

UNIT – III

Starting Up Financial Issues: Feasibility Analysis - The cost and process of raising capital – Unique funding issues of a high-tech ventures - Funding with Equity, Financing with Debt- Funding startups with bootstrapping- crowd funding- strategic alliances.

UNIT – IV

Start-Up Survival and Growth: Stages of growth in a new venture- Growing with the market - Growing within the industry- Venture life patterns- Reasons for new venture failures Scaling Ventures – preparing for change - Leadership succession, Support for growth and sustainability of the venture.

UNIT – V

Planning for Harvest and Exit: Dealing with Failure: Bankruptcy, Exit Strategies Selling the business - Cashing out but staying in-being acquired- Going Public (IPO) – Liquidation.

Text Books:

1. Neck, H. M., Neck, C. P., & Murray, E. L. (2023). Entrepreneurship: The practice and mindset (3rd ed.). SAGE Publications. ISBN: 9781071914694.
2. Kuratko, D. F., & Hornsby, J. S. (2020). New venture management: The entrepreneur's roadmap for development, management, and growth (3rd ed.). Routledge. ISBN: 9780367466725.

Reference Books:

1. Gupta, A., George, G., & Fewer, T. J. (2024). Venture meets mission: Aligning people, purpose, and profit to innovate and transform society. Stanford University Press. ISBN: 9781503636520.
2. Bhimani, A. (2022). Financial management for technology start-ups: A handbook for growth. Kogan Page. ISBN: 9781398605492

Web Links:

1. https://onlinecourses.swayam2.ac.in/imb20_mg22/preview
2. <https://archive.nptel.ac.in/courses/110/106/110106141/>

Relevant cases have to be discussed in each unit and in examination case study is compulsory from any unit.

CONSUMER ANALYTICS

	L	T	P	C
Course Code: 2508MS20	2		1	3

Course Outcomes:

At the end of the Course, Student will be able to:

- CO1:** Apply the key concepts of the marketing management process, linking them to consumer analytics and insights.
- CO2:** Analyze and design non-linear pricing strategies for profit maximization.
- CO3:** Make use of conjoint analysis techniques.
- CO4:** Measure consumer value using metrics.
- CO5:** Compare consumer analytics in various domains like advertising, retailing, and internet & social marketing.

Mapping of Course Outcomes with Program Outcomes:

CO / PO	PO1	PO2	PO3	PO4	PO5	PO6	PO7	PO8
CO1	3	3	2	3	3	2	3	3
CO2	3	3	3	3	3	3	3	3
CO3	3	3	3	2	3	3	3	3
CO4	3	3	3	2	3	3	3	3
CO5	3	3	2	3	3	3	3	3

Mapping of Course Outcomes with Program Specific Outcomes:

CO / PSO	PSO1	PSO2	PSO3
CO1	3	2	3
CO2	3	3	3
CO3	3	3	3
CO4	3	3	3
CO5	3	3	3

UNIT – I

Marketing Management and Consumer Analytics: The Marketing Management Process and its link to Consumer Analytics and Consumer Insights, Correlation, Simple linear regression, Trend, seasonality, Exponential smoothing.

UNIT – II

Pricing: Non-linear pricing strategies for profit maximization, price skimming and sales, optimal pricing, price bundling, demand curve and the willingness to pay.

UNIT – III

Consumer Insights: Conjoint analysis, product attributes and levels, full profile conjoint analysis, choice based conjoint analysis, random utility theory.

UNIT – IV

Consumer Value: Lifetime Consumer value, relation between spending, customer acquisition and customer retention, Market basket analysis, RFM analysis.

UNIT – V

Market Segmentation: Cluster analysis, collaborative filtering and classification trees for segmentation, Application of Consumer Analytics in Advertising, Retailing and Internet & Social Marketing.

Text Books:

1. Mothersbaugh, D., Kleiser, S. B., & Hawkins, D. (2024). Consumer behavior: Building marketing strategy (15th ed.). McGraw Hill Education. ISBN: 9781266131615
2. de Mesquita, J. C., & Kosteljik, E. (2021). Marketing analytics: Statistical tools for marketing and consumer behavior using SPSS. Routledge. ISBN: 9781032052199.

Reference Books:

1. Charan, A. (2021). Marketing analytics practitioner's guide: Volume 1 – Brand and consumer. World Scientific Publishing. ISBN: 9789811238446.
2. France, S. L., & Ghose, S. (2021). Marketing analytics: Methods, practice, implementation, and links to other fields. Springer. ISBN: 9783030654320.

Web Links:

1. <https://archive.nptel.ac.in/courses/110/105/110105142/>
2. <https://www.coursera.org/learn/quantitative-customer-insights>

Relevant cases have to be discussed in each unit and in examination case study is compulsory from any unit.

E-MAIL MARKETING

	L	T	P	C
Course Code: 2508MS33	2		1	3

Course Outcomes:

At the end of the Course, Student will be able to:

- CO1:** Explain the fundamental concepts, history, and the significance of email marketing.
- CO2:** Analyze the elements and strategies involved in organizing and managing mailing lists.
- CO3:** Develop compelling and effective email content, including newsletters and announcements.
- CO4:** Examine the benefits and strategies for email automation.
- CO5:** Apply techniques for tracking and analyzing email marketing performance.

Mapping of Course Outcomes with Program Outcomes:

CO / PO	PO1	PO2	PO3	PO4	PO5	PO6	PO7	PO8
CO1	3	3	2	3	3	2	3	3
CO2	3	3	3	3	3	3	3	3
CO3	3	3	3	3	3	3	3	3
CO4	3	3	3	3	3	3	3	3
CO5	3	3	3	3	3	3	3	3

Mapping of Course Outcomes with Program Specific Outcomes:

CO / PSO	PSO1	PSO2	PSO3
CO1	3	2	3
CO2	3	3	3
CO3	3	3	3
CO4	3	3	3
CO5	3	3	3

UNIT – I

Introduction to E-mail Marketing: Meaning, Importance, Email Marketing Goals, History of Email Marketing, Advantages and Disadvantages of Email Marketing and reasons for increase in email marketing. Popular Email Marketing Tools.

UNIT – II

Organizing the Mailing List: Mailing List elements and concepts, Developing E-mails to Drive Results, Critical Design Factors, Utilize and Optimization of Preheader, Headline, and Call-to- Action and Subject Lines. Subscriber List Management Strategies & related Issues.

UNIT – III

Email Content: Composing various types of e-mails, Newsletters and Announcements Using images & videos, how to write Effective content and subject line, Landing Pages- Meaning, design & Factors to be considered. Development of a Brand Strategy through E-mail Marketing and integration with other digital tools.

UNIT – IV

Automating Emails and Spam Compliance: Marketing Automation, Why Email automation is required, Designing an effective Email campaign, The Demonstrated Value of Automated Emails, Welcome e-mails. Date-Based Triggers, Action and Event Triggers. SPAM Testing and minimizing related complaints, Blacklisting.

UNIT – V

Analyzing and Tracking Email Marketing: Tracking Email Marketing Reports, Types of Tracking reports, Bounce Rates /Non-bounce rates, Open Rates & Click through rates. Tracking email data, Optimization of Call-to-action and Lead Capture.

Text Books:

1. Klinck, B. (2022). Email marketing that doesn't suck: Have fun writing emails your subscribers will want to read (and that will actually make you money!). Lioncrest Publishing. ISBN: 9781544527376.
2. Blokdyk, G. (2021). Email marketing campaigns high deliverability: A complete guide – 2021 edition. Emereo. ISBN: 9781867447146

Reference Books:

1. Stephens, J. (2021). Email marketing simplified. Econo Publishing Company. ISBN: 9781648303326.
2. Vincent, B. (2021). Email marketing. RWG Marketing. ISBN: 9781648303616.

Web Links:

1. <https://www.coursera.org/learn/think-outside-the-inbox>
2. <https://www.coursera.org/projects/mailchimp-build-email-marketing-campaign>

Relevant cases have to be discussed in each unit and in examination case study is compulsory from any unit.

MOBILE MARKETING

Course Code: 2508MS67

L	T	P	C
2		1	3

Course Outcomes:

At the end of the Course, Student will be able to:

- CO1:** Explain the history, definition, scope, and importance of mobile marketing and mobile commerce.
- CO2:** Analyze different types of mobile applications.
- CO3:** Differentiate between various mobile payment methods.
- CO4:** Develop effective mobile marketing strategies.
- CO5:** Identify the major concerns related to privacy and security in mobile marketing.

Mapping of Course Outcomes with Program Outcomes:

CO / PO	PO1	PO2	PO3	PO4	PO5	PO6	PO7	PO8
CO1	3	3	2	3	3	2	3	3
CO2	3	3	3	3	3	3	3	3
CO3	3	3	3	3	3	3	3	3
CO4	3	3	3	3	3	3	3	3
CO5	3	3	3	3	3	3	3	3

Mapping of Course Outcomes with Program Specific Outcomes:

CO / PSO	PSO1	PSO2	PSO3
CO1	3	2	3
CO2	3	3	3
CO3	3	3	3
CO4	3	3	3
CO5	3	3	3

UNIT – I

Introduction to Mobile Marketing: History, Definition, Scope, and Importance of Mobile marketing. Mobile Commerce - Definition, History, Scope, Characteristics, Applications, attributes and benefits of M-commerce. Growth and Future Prospects of M-Commerce.

UNIT – II

Mobile Applications: Mobile apps- Meaning, types & Importance. Mobile Gaming concept, Scenario in India and Future scope of online gaming. Text Message Marketing, Mobile advertising, Concept, types, advantages and limitations, Features of a good Mobile Marketing programme.

UNIT – III

Mobile Payments and Mobile Entertainment: Mobile payments: Mobile wallets, mobile browser payments, in-app mobile payments and mobile or wireless credit card transfers. Mobile Payment Models, Mobile Payment Service Providers. Mobile entertainment: Definition, Indian Scenario, OTT platforms, Mobile TV and Live TV, Mobile music. Mobile banking- Features, types and benefits. Mobile FinTech.

UNIT – IV

Mobile Marketing Strategies: Mobile marketing vs. traditional marketing, Integration of traditional marketing with mobile marketing campaigns. Mobile marketing campaign- Planning, Implementation and Optimization. Mobile engagement.

UNIT – V

Privacy and Security in Mobile Marketing: Major concerns/issues related to privacy and security in mobile marketing. Challenges and Best Practices in Mobile Marketing. Future scope for mobile marketing.

Text Books:

1. McCabe, M. B., Becker, M., Berney, P., & Hanley, M. (2022). Mobile marketing essentials. Stukent. ISBN: 9780999630213
2. Bentz, B. (2022). Relevance raises response: How to engage and acquire with mobile marketing. SkillBites LLC. ISBN: 9781952281648

Reference Books:

1. Vincent, B. (2021). Mobile marketing. RWG Marketing. ISBN: 9781648303753.
2. Author Unknown. (2022). The complete guide to mobile marketing for newbies. Independently Published. ISBN: 9798353783756.

Web Links:

1. <https://www.coursera.org/learn/mobile-marketing-optimization-tactics-and-analytics>
2. <https://www.udemy.com/course/how-to-create-grow-a-mobile-app-iphone-android-business/?couponCode=NVDIN35>

Relevant cases have to be discussed in each unit and in examination case study is compulsory from any unit.

SEARCH ENGINE OPTIMIZATION

Course Code: 2508MS75	L	T	P	C
	2		1	3

Course Outcomes:

At the end of the Course, Student will be able to:

- CO1:** Explain the basic concepts and significance of search engine optimization (SEO).
- CO2:** Make use of different tools like Google Search Console for SEO analysis and issue resolution.
- CO3:** Discover the importance and influence factors of on-page SEO
- CO4:** Differentiate between ethical and unethical linking practices
- CO5:** Apply SEO techniques for blogs, content management systems, local search, and mobile search

Mapping of Course Outcomes with Program Outcomes:

CO / PO	PO1	PO2	PO3	PO4	PO5	PO6	PO7	PO8
CO1	3	3	2	3	3	2	3	3
CO2	3	3	3	3	3	3	3	3
CO3	3	3	3	3	3	3	3	3
CO4	3	3	3	3	3	3	3	3
CO5	3	3	3	3	3	3	3	3

Mapping of Course Outcomes with Program Specific Outcomes:

CO / PSO	PSO1	PSO2	PSO3
CO1	3	2	3
CO2	3	3	3
CO3	3	3	3
CO4	3	3	3
CO5	3	3	3

UNIT – I

Introduction to SEO: Concepts of search engine optimization (SEO), Relevance, Importance, Popularity, Trust, Authority, Search engines and directories, how search engines work, Crawlers, robots, spiders, Algorithms, Search engine indexing, Ranking, Directories, Website architecture, Static pages, Dynamic pages.

UNIT – II

Search Engine Friendliness and Specific Rankings: Page coding, managing spiders/robots, Crawlability, Rewriting pages, Subdomains, Alexa ranking, Image optimization, Google search console analysis, crawler issues, remove urls, sitemap submission

UNIT – III

On-page SEO: Importance, influence factors, Optimizing Web Page, Website Optimization, title, description and keyword tags, header tags, Anchor Text, Navigation Links, Contextual links, Canonical URLs, Page Nations, keyword research, meta tag optimization, SEO content optimization, sitemap creation submission, robots.txt

UNIT – IV

Off-page SEO: Importance, influence factors, Right and wrong ways to link, Reciprocal links, three-way links, purchased links, link networks, Redirected links, Link bait, Trust rank and worthless links, Quality directories Performing and Implementing SEO, SEO goals, and Commercial intent, Fixing broken links, Sitemaps, Useful directory links, complaining to search engines, How to address a copyright violation

UNIT – V

Web 2.0 and Other Important Considerations: Website ecosystem, Micro sites, RSS feeds, Blogosphere, social media, Google calendar, Press releases, SEO for blogs, SEO for content management systems, SEO for local search, SEO for mobile search, Measurements, Google API, SEO tools, Free tools, Research and resources, Google my business listing, Google places

Text Books:

- 1 Clarke, A. (2023). SEO 2024: Learn search engine optimization with smart internet marketing strategies. Independently Published. ISBN: 9798863451626.
- 2 Veglis, A., & Giomelakis, D. (2021). Search engine optimization. MDPI AG. ISBN: 9783039368181

Reference Books:

- 1 Enge, E., Spencer, S., & Stricchiola, J. (2023). The art of SEO: Mastering search engine optimization (4th ed.). O'Reilly Media. ISBN: 9781098102616
- 2 Clarke, A. (2020). SEO 2021: Learn search engine optimization with smart internet marketing strategies. Independently Published. ISBN: 9798576183265

Web Links:

- 1 <https://www.coursera.org/learn/search-engine-optimization>
- 2 <https://www.coursera.org/specializations/seo>

Relevant cases have to be discussed in each unit and in examination case study is compulsory from any unit.

SOCIAL MEDIA MARKETING

Course Code: 2508MS77

L	T	P	C
2		1	3

Course Outcomes:

At the end of the Course, Student will be able to:

- CO1:** Explain the meaning and definition of digital and social media marketing.
- CO2:** Identify best practices and pitfalls in sharing content on social media and bookmarking websites.
- CO3:** Develop a social media strategy by setting goals, planning, and choosing appropriate strategies.
- CO4:** Perceive the use of major social media platforms like Facebook, LinkedIn, Twitter, and YouTube for marketing purposes.
- CO5:** Assess the role of social analytics in measuring social media performance.

Mapping of Course Outcomes with Program Outcomes:

CO / PO	PO1	PO2	PO3	PO4	PO5	PO6	PO7	PO8
CO1	3	2	3	3	2	2	3	3
CO2	3	3	3	3	3	2	3	3
CO3	3	3	3	3	3	3	3	3
CO4	3	2	3	3	3	2	3	3
CO5	3	3	3	3	3	3	3	3

Mapping of Course Outcomes with Program Specific Outcomes:

CO / PSO	PSO1	PSO2	PSO3
CO1	3	2	3
CO2	3	3	3
CO3	3	3	3
CO4	3	3	3
CO5	3	3	3

UNIT – I

Introduction to Social Media Marketing: Meaning-Definition-Types of Social Media Websites-Mobile Apps-Email- social media-Variou Social Media Websites; Blogging-Types, Platforms.

UNIT – II

Social Media Management: Social Media and Target Audience-Sharing content on social media-Book marking websites; DO’s and Don’ts of social media.

UNIT – III

Social Media Strategy: Goals, Planning, Strategies, Monitoring Analysis; Tips of Social Media Marketing-Customization; Social Media Optimization; Social Media Promotion-paid advertising – other methods-social media ROI.

UNIT – IV

Social Media for Marketing: Facebook, LinkedIn, Twitter, YouTube. Establishing Relationship with customer’s social media.

UNIT – V

Social Analytics: Automation and social media- social media and other types of Marketing, Managing Tools of social media.

Text Books:

1. Tuten, T. L. (2021). Social media marketing (4th ed.). SAGE Publications Ltd. ISBN: 9781529731989.
2. Zahay, D., Roberts, M. L., Parker, J., Barker, D. I., & Barker, M. S. (2021). Social media marketing: A strategic approach (3rd ed.). Cengage Learning. ISBN: 9780357516188

Reference Books:

1. Butow, E., Herman, J., Liu, S., Robinson, A., & Allton, M. (2020). Ultimate guide to social media marketing. Entrepreneur Press. ISBN: 9781599186740
2. Amiri, S., Kamangar, T., & Steve, M. (2021). Social media marketing. Silk Road Publishing. ISBN: 9781927060933

Web Links:

1. <https://www.coursera.org/learn/social-media-marketing-introduction>
2. <https://www.udemy.com/course/best-social-media-marketing-training-course/?couponCode=LETSLEARNNOWPP>

Relevant cases have to be discussed in each unit and in examination case study is compulsory from any unit.

CONTENT MARKETING

	L	T	P	C
Course Code: 2508MS23	2		1	3

Course Outcomes:

At the end of the Course, Student will be able to:

- CO1:** Explain the definition, history, and evolution of content marketing.
- CO2:** Identify various tools of content marketing, such as blogs, social media, webinars, videos, newsletters, and podcast.
- CO3:** Develop the content marketing strategy.
- CO4:** Apply Content Management Systems (CMS).
- CO5:** Analyze content marketing strategies used in different sectors.

Mapping of Course Outcomes with Program Outcomes:

CO / PO	PO1	PO2	PO3	PO4	PO5	PO6	PO7	PO8
CO1	3	2	3	3	2	2	3	3
CO2	3	3	3	3	3	2	3	3
CO3	3	3	3	3	3	3	3	3
CO4	3	2	3	3	3	2	3	3
CO5	3	3	3	3	3	3	3	3

Mapping of Course Outcomes with Program Specific Outcomes:

CO / PSO	PSO1	PSO2	PSO3
CO1	3	2	3
CO2	3	3	3
CO3	3	3	3
CO4	3	3	3
CO5	3	3	3

UNIT – I

Introduction to Content Marketing: Definition, history, evolution, objectives, importance, role of content marketing in businesses. Challenges and opportunities.

UNIT – II

Tools of Content Marketing: Blogs, branch guide/folder, social media, Case study, Webinars, Video publications, articles, Newsletters, Mobile Apps, Info-graphic, e-book, Whitepapers, podcasts, audio publications, websites and E-mails. Merits and challenges in using these tools. Content marketing and online marketing, influencer marketing.

UNIT – III

Content Marketing Strategy: Definition, objectives, strategic plan, Analysis of Business and understanding customers, Content marketing mix, timelines, budget and optimizing and content, Role of SEO in content marketing.

UNIT – IV

Content Management: Definition, Phases, CMS, Distribution of Content, Strategies in content distribution - guest blogging, repurposing and republishing, Importance of content Management, Metrics to monitor content.

UNIT – V

Cases in Content Marketing: Content Strategies used in sectors like Automobile, Services, FMCG, Pharmaceuticals, Airline, Future Trends in Content Marketing.

Text Books:

1. Pulizzi, J., & Piper, B. (2023). Epic content marketing: Break through the clutter with a different story, get the most out of your content, and build a community in your marketplace (2nd ed.). McGraw Hill. ISBN: 9781264774456.
2. Scott, D. M. (2022). The new rules of marketing and PR: How to use content marketing, podcasting, social media, AI, live video, and newsjacking to reach buyers directly (8th ed.). Wiley. ISBN: 9781119854296

Reference Books:

1. Egan, J. (2022). The stripped-down guide to content marketing: Success secrets for beginners. Independently published. ISBN: 9781737472703
2. Hörner, T. (2022). Werbewirkung und Controlling im Content-Marketing: Wirkmechanismen erkennen, Controlling optimieren und Strategie anpassen. Springer Gabler. ISBN: 9783658370145

Web Links:

1. <https://www.coursera.org/learn/content-marketing>
2. <https://www.coursera.org/learn/digital-content-planning-and-management>

Relevant cases have to be discussed in each unit and in examination case study is compulsory from any unit.

AFFILIATE MARKETING AND GOOGLE ADSENSE

Course Code: 2508MS02	L	T	P	C
	2		1	3

Course Outcomes:

At the end of the Course, Student will be able to:

- CO1:** Explain the history, definition, and mechanisms of affiliate marketing.
- CO2:** Identify different types of affiliate marketing.
- CO3:** Examine the process of setting up an affiliate marketing program.
- CO4:** Analyze the importance of keyword research.
- CO5:** Develop a Google Ads account by choosing appropriate campaign types and goals.

Mapping of Course Outcomes with Program Outcomes:

CO / PO	PO1	PO2	PO3	PO4	PO5	PO6	PO7	PO8
CO1	3	2	3	3	2	2	3	3
CO2	3	3	3	3	3	2	3	3
CO3	3	3	3	3	3	3	3	3
CO4	3	2	3	3	3	2	3	3
CO5	3	3	3	3	3	3	3	3

Mapping of Course Outcomes with Program Specific Outcomes:

CO / PSO	PSO1	PSO2	PSO3
CO1	3	2	3
CO2	3	3	3
CO3	3	3	3
CO4	3	3	3
CO5	3	3	3

UNIT – I

Fundamentals of Affiliate Marketing: History, Definition and working of affiliate marketing, parties involved in Affiliate Marketing, Pros and Cons of Affiliate Marketing, The basis of Affiliate Marketing, How Affiliate Marketing works, Affiliate Program payment methods, Cookies and Affiliates, Tiered Affiliate Marketing, Cross selling and up selling, Multi-tier marketing and commissions, List of affiliate marketing software

UNIT – II

Types of Affiliate Marketing - Search affiliates - Price comparison service website - Loyalty websites - Cause related and coupon websites - Content and niche market website - Personal weblogs and website syndicates - Email marketing and shopping directories - Registration or co-registration affiliates - File sharing affiliates.

UNIT – III

Setting Up Affiliate Marketing Program - How to attract affiliates-Hosting and implementing an affiliate program-Growing you're Affiliate Numbers. Setting up an affiliate program-Affiliate network service agreement-Data feeds and customer returns. Merchants/publisher management-Setting up an Affiliate Marketing Software-Affiliate program promotion and content pages, Screen Affiliates-Combating affiliate fraud.

UNIT – IV

Introduction to Google Ads: Introduction to Google Ads, Google Ads Terminology, The Role of Google Ads, Understanding the Google Network, How Paid Search Works, The Pillars of Google Ad Success, **Keyword Research:** Meaning of Keyword, Types of Keywords, Keyword Research Keyword Research Methodology, How to Choose the Right Keywords to Target.

UNIT – V

Creating a Google Ads Account: Campaign, Campaign Types, Campaign Goals, Naming Your Campaign, Choosing Campaign Types, Location, Targeting, Languages, Budget, Delivery Method, Bid Strategies: Manual vs. Automated, Keyword Match Types, Ad Creation, Ad Rank & Quality Score, Landing Pages, Conversion Tracking.

Text Books:

1. Vincent, B. (2021). Affiliate marketing. Revival Waves of Glory Books & Publishing. ISBN: 9781648304392.
2. Smm Publishing. (2020). Affiliate marketing for beginners: 12 steps to your affiliate marketing business in 2021 (12th ed.). Smm Publishing. ISBN: 9781648086465

Reference Books:

1. Calicchio, S. (2021). The Google AdSense handbook: The introductory guide to the web's most famous and popular advertising programme. Independently published. ISBN: 9791220275965
2. Kelson, J. (2021). Google AdSense profits. Storytel.

Web Links:

1. <https://www.udemy.com/course/free-affiliate-marketing-course-for-beginners/>
2. <https://www.coursera.org/projects/google-ads-beginner>

Relevant cases have to be discussed in each unit and in examination case study is compulsory from any unit

MINOR PROGRAM ELECTIVE COURSES

MINOR 1: FINTECH & DIGITAL FINANCE

BLOCKCHAIN & CRYPTOCURRENCIES IN FINANCIAL SERVICES

Course Code: 2508MS09	L	T	P	C
	2		1	3

Course Outcomes:

At the end of the Course, Student will be able to:

- CO1:** Explain the components of blockchain such as blocks, hashing, Merkle trees, and consensus mechanisms
- CO2:** Apply the principles of blockchain to understand how cryptocurrencies like Bitcoin and Ethereum function.
- CO3:** Examine the structure and use cases of smart contracts in insurance, lending, and crowdfunding.
- CO4:** Demonstrate how blockchain can be used for cross-border payments, KYC/AML compliance, fraud detection.
- CO5:** Analyze the legal, tax, and compliance issues surrounding digital assets across countries.

Mapping of Course Outcomes with Program Outcomes:

CO / PO	PO1	PO2	PO3	PO4	PO5	PO6	PO7	PO8
CO1	3	3	2	3	3	2	3	3
CO2	3	3	2	3	3	3	3	3
CO3	3	3	2	3	3	3	3	3
CO4	3	3	3	3	3	3	3	3
CO5	3	3	3	3	3	3	3	3

Mapping of Course Outcomes with Program Specific Outcomes:

CO / PSO	PSO1	PSO2	PSO3
CO1	3	2	3
CO2	3	2	3
CO3	3	3	3
CO4	3	3	3
CO5	3	3	3

UNIT – I

Introduction to Blockchain Technology: Distributed Ledger Technology (DLT), Components of Blockchain: Blocks, Hashing, Merkle Tree, Types: Public vs. Private vs. Consortium, Consensus Mechanisms: Proof of Work, Proof of Stake, Applications across industries.

UNIT – II

Cryptocurrencies: Bitcoin, Ethereum & Altcoins: History and evolution of cryptocurrencies, Bitcoin protocol and mining basics, Ethereum and smart contracts, Comparison of major altcoins, Crypto wallets and exchanges.

UNIT – III

Smart Contracts & Decentralized Finance (DeFi): What are Smart Contracts?, Use cases in insurance, lending, crowdfunding, DeFi ecosystems and protocols (e.g., Uniswap, Aave), Tokenization and asset digitization, Risks and limitations of DeFi.

UNIT – IV

Blockchain Use Cases in Banking and Insurance: Cross-border payments, KYC/AML through blockchain, Fraud prevention and audit trails, Blockchain in claims and underwriting, Real-life case studies (e.g., Ripple, IBM Blockchain).

UNIT – V

Regulatory Environment & Future Trends in Digital Assets: Global regulatory landscape (India, US, EU), Taxation and legal implications, Central Bank Digital Currencies (CBDCs), NFTs and the Metaverse, Future trends and career opportunities.

Text Books:

1. Yermack, D. (2021). Corporate governance and blockchain technology. Oxford University Press. ISBN: 9780198869077
2. Narayanan, A., Bonneau, J., Felten, E., Miller, A., & Goldfeder, S. (2021). Bitcoin and cryptocurrency technologies: A comprehensive introduction (2nd ed.). Princeton University Press. ISBN: 9780691215414

Reference Books:

1. Catalini, C., & Gans, J. S. (Eds.). (2022). The economics of blockchain technology and cryptocurrencies. MIT Press. ISBN: 9780262547036
2. Franco, P. (2021). Understanding Bitcoin: Cryptography, engineering and economics. Wiley. ISBN: 9781119163775

Web Links:

1. <https://www.coursera.org/specializations/blockchain>
2. <https://www.udemy.com/course/blockchain-and-cryptocurrency-explained/>

Relevant cases have to be discussed in each unit and in examination case study is compulsory from any unit.

DIGITAL PAYMENT SYSTEMS & FINTECH INNOVATIONS

Course Code: 2508MS30	L	T	P	C
	2		1	3

Course Outcomes:

At the end of the Course, Student will be able to:

- CO1:** Explain the evolution and types of digital payment systems along with the regulatory role of RBI and NPCI.
- CO2:** Apply knowledge of the FinTech ecosystem to analyze the role of key players and business models.
- CO3:** Analyze cybersecurity threats in digital finance and evaluate measures for secure transactions and data protection.
- CO4:** Apply concepts of RegTech, InsurTech, and LendingTech to real-life use cases in compliance, insurance, and lending.
- CO5:** Analyze the impact of FinTech innovations on financial inclusion and identify future skill requirements through case-based learning.

Mapping of Course Outcomes with Program Outcomes:

CO / PO	PO1	PO2	PO3	PO4	PO5	PO6	PO7	PO8
CO1	3	3	2	3	3	2	3	3
CO2	3	3	2	3	3	3	3	3
CO3	3	3	3	3	3	3	3	3
CO4	3	3	3	3	3	3	3	3
CO5	3	3	3	3	3	3	3	3

Mapping of Course Outcomes with Program Specific Outcomes:

CO / PSO	PSO1	PSO2	PSO3
CO1	3	3	3
CO2	3	3	3
CO3	3	3	3
CO4	3	3	3
CO5	3	3	3

UNIT – I

Overview of Digital Payments: Evolution of payment systems, Types of digital payments: UPI, NEFT, IMPS, RTGS, Wallets, Digital payment trends in India and globally, Role of NPCI and RBI, Payment gateways and aggregators.

UNIT – II

FinTech Ecosystem & Key Players: Definition and scope of FinTech, FinTech start-up landscape, Role of banks and NBFCs, Partnerships and collaborations, Case study: Razorpay, Paytm, Google Pay.

UNIT – III

Cybersecurity in Digital Finance: Digital fraud types and detection, Encryption and secure transactions, Data privacy and protection (GDPR, PDPA), Role of blockchain in cybersecurity, Secure mobile and web applications.

UNIT – IV

RegTech, InsurTech, and LendingTech: RegTech: Automation in compliance, InsurTech: Chatbots, Telematics, Claims automation, LendingTech: Peer-to-peer, Digital underwriting, Sandbox and innovation hubs, Case study: Policybazaar, LendingKart.

UNIT – V

Case Studies & Future Scope: FinTech unicorns and business models, Rural financial inclusion via FinTech, QR Code and Sound-based payments, Future skills for FinTech professionals, Final group project/presentation

Text Books:

1. Gomber, P., Kauffman, R. J., Parker, C., & Weber, B. W. (2022). FinTech: Foundations, applications, and regulatory challenges. Springer. ISBN: 9783030863938
2. Arner, D. W., Barberis, J. N., & Buckley, R. P. (2021). The evolution of FinTech: A new post-crisis paradigm? Routledge. ISBN: 9780367659248

Reference Books:

1. Chen, M. A., Wu, Q., & Yang, B. (2021). Digital finance and financial inclusion in Asia. Springer. ISBN: 9789811641390
2. Philippon, T. (2020). The FinTech opportunity. MIT Press. ISBN: 9780262044841

Web Links:

1. <https://www.coursera.org/learn/fintech>
2. <https://www.ibm.com/topics/fintech>

Relevant cases have to be discussed in each unit and in examination case study is compulsory from any unit.

AI & ALGORITHMIC TRADING

Course Code: 2508MS04

L	T	P	C
2		1	3

Course Outcomes:

At the end of the Course, Student will be able to:

- CO1:** Understand the structure of financial markets, types of trading, and the role of exchanges and regulators.
- CO2:** Apply the concepts and tools of algorithmic trading to evaluate its benefits, platforms, and lifecycle.
- CO3:** Analyze machine learning techniques used in trading for forecasting and sentiment analysis.
- CO4:** Apply risk management strategies in AI trading while addressing model risks and ethical considerations.
- CO5:** Analyze and implement trading algorithms using Python, APIs, and evaluate their performance through a capstone project.

Mapping of Course Outcomes with Program Outcomes:

CO / PO	PO1	PO2	PO3	PO4	PO5	PO6	PO7	PO8
CO1	3	3	2	3	3	2	3	3
CO2	3	3	2	3	3	3	3	3
CO3	3	3	3	3	3	3	3	3
CO4	3	3	3	3	3	3	3	3
CO5	3	3	3	3	3	3	3	3

Mapping of Course Outcomes with Program Specific Outcomes:

CO / PSO	PSO1	PSO2	PSO3
CO1	3	3	3
CO2	3	3	3
CO3	3	3	3
CO4	3	3	3
CO5	3	3	3

UNIT – I

Basics of Financial Markets & Trading: Equity, commodity, currency markets, Types of trading: intraday, swing, arbitrage, Order types: market, limit, stop loss, Technical vs. fundamental analysis, Role of exchanges and regulators (SEBI)

UNIT – II

Introduction to Algorithmic Trading: What is algo trading?, History and global evolution, Tools and platforms (Zerodha Streak, TradingView), Benefits and challenges, Algo order lifecycle

UNIT – III

Machine Learning in Trading: Introduction to ML algorithms, Use cases in sentiment analysis and forecasting, Predictive analytics for price trends, Supervised vs. unsupervised learning, Data sources: Yahoo Finance, Quandl

UNIT – IV

Risk Management in AI Trading: Market risks and mitigation strategies, Portfolio diversification, Role of backtesting, Overfitting and model risk, Ethics and governance in AI trading

UNIT – V

Tools, Programming & Capstone Project: Basics of Python for trading, Introduction to APIs (Zerodha Kite, Alpha Vantage), Designing a simple trading bot, Evaluation metrics (Sharpe ratio, drawdown), Capstone project with backtesting

Text Books:

1. Chan, E. P. (2021). Algorithmic trading: Winning strategies and their rationale (2nd ed.). Wiley. ISBN: 9781119645884
2. Sengupta, S. (2022). Artificial intelligence for algorithmic trading: Mastering trading systems and strategies with Python. Apress. ISBN: 9781484268146

Reference Books:

1. Narayanan, S., & Lakshmanan, K. (2021). AI and big data analytics for algorithmic trading: A comprehensive guide. CRC Press. ISBN: 9780367359156
2. Krollner, B. (2020). Artificial intelligence in finance and algorithmic trading. Springer. ISBN: 9783030447319

Web Links:

1. <https://www.coursera.org/learn/ai-trading>
2. <https://zerodha.com/varsity/module/trading-psychology/>

Relevant cases have to be discussed in each unit and in examination case study is compulsory from any unit.

MINOR PROGRAM ELECTIVE COURSES
MINOR 2: PRODUCT STRATEGY & INNOVATION MANAGEMENT
STRATEGIC PRODUCT MANAGEMENT

	L	T	P	C
Course Code: 2508MS82	2		1	3

Course Outcomes:

At the end of the Course, Student will be able to:

- CO1:** Explain the evolving role of product managers and master key phases of the product lifecycle.
- CO2:** Apply market research techniques to extract actionable customer insights for product decisions.
- CO3:** Analyze positioning, branding, and differentiation strategies for competitive advantage.
- CO4:** Develop product roadmaps and manage product portfolios using prioritization tools.
- CO5:** Evaluate go-to-market strategies and measure product performance using key metrics.

Mapping of Course Outcomes with Program Outcomes:

CO / PO	PO1	PO2	PO3	PO4	PO5	PO6	PO7	PO8
CO1	3	3	3	3	2	3	3	3
CO2	3	3	3	3	3	2	3	3
CO3	3	3	3	3	3	3	3	3
CO4	3	3	3	3	3	3	3	3
CO5	3	3	3	3	3	3	3	3

Mapping of Course Outcomes with Program Specific Outcomes:

CO / PSO	PSO1	PSO2	PSO3
CO1	3	3	3
CO2	3	3	3
CO3	3	3	3
CO4	3	3	3
CO5	3	3	3

UNIT – I

Role of Product Managers & Product Lifecycle: Understanding the product manager's role, Phases of the product lifecycle (PLC), Product-market fit and positioning, Cross-functional collaboration in product teams, Skillsets and tools for product managers

UNIT – II

Market Research & Customer Insights: Primary and secondary research techniques, Customer journey mapping, Focus groups and surveys, Personas and segmentation, Voice of customer (VoC) analytics

UNIT – III

Positioning, Branding, and Differentiation: Value proposition design, Branding essentials and identity development, Competitive analysis (SWOT, Porter's 5 Forces), USP and customer value matrix, Product positioning strategies

UNIT – IV

Product Roadmaps and Portfolio Management: Prioritization techniques (RICE, MoSCoW), Strategic planning with product roadmaps, Product lifecycle extension strategies, Managing multiple products, KPIs and dashboard tracking

UNIT – V

Go-to-Market Strategies & Performance Metrics: GTM frameworks (AIDA, STP), Launch planning and execution, Pricing strategies and distribution models, Sales enablement and channel strategy, Post-launch metrics (adoption rate, churn, NPS)

Text Books:

1. LeMay, M. (2022). Product management in practice: A practical, tactical guide for your first day and every day after (2nd ed.). O'Reilly Media. ISBN: 9781098119737
2. Singh, G. (2021). Product management and strategy: The ultimate guide that creates real value. Notion Press. ISBN: 9781637454763

Reference Books:

1. Crumlish, C. (2022). Product management for UX people: From designing to thriving in a product world. Rosenfeld Media. ISBN: 9781933820712
2. Schmidt, T. (2021). Strategic project management made simple: Solution tools for leaders and teams (2nd ed.). Wiley. ISBN: 9781119718178

Web Links:

1. <https://www.coursera.org/specializations/product-management>
2. <https://www.productschool.com/blog/product-management-2/product-launch-go-to-market-strategy/>

Relevant cases have to be discussed in each unit and in examination case study is compulsory from any unit.

AGILE FRAMEWORKS FOR BUSINESS INNOVATION

	L	T	P	C
Course Code: 2508MS03	2		1	3

Course Outcomes:

At the end of the Course, Student will be able to:

- CO1:** Explain the core principles of Agile, Scrum, and Kanban and differentiate them from traditional models.
- CO2:** Apply backlog creation, sprint planning, and agile estimation techniques using digital tools.
- CO3:** Analyze the integration of agile methodologies in product development and marketing workflows.
- CO4:** Demonstrate team and stakeholder management skills within an agile environment.
- CO5:** Evaluate agile success stories and case studies to measure agile maturity and impact.

Mapping of Course Outcomes with Program Outcomes:

CO / PO	PO1	PO2	PO3	PO4	PO5	PO6	PO7	PO8
CO1	3	3	3	3	3	3	3	3
CO2	3	3	3	3	3	3	3	3
CO3	3	3	3	3	3	3	3	3
CO4	3	3	3	3	3	3	3	3
CO5	3	3	3	3	3	3	3	3

Mapping of Course Outcomes with Program Specific Outcomes:

CO / PSO	PSO1	PSO2	PSO3
CO1	3	3	3
CO2	3	3	3
CO3	3	3	3
CO4	3	3	3
CO5	3	3	3

UNIT – I

Principles of Agile, Scrum & Kanban: Agile manifesto and core principles, Scrum roles: Product Owner, Scrum Master, Team, Daily stand-ups, retrospectives, Kanban boards and WIP limits, Agile vs. Waterfall comparison

UNIT – II

Product Backlog Creation and Sprint Planning: User stories and acceptance criteria, Estimation techniques (story points, T-shirt sizing), Sprint planning and review sessions, Prioritizing features, Agile tools: Trello, Jira, Asana

UNIT – III

Agile in Product Development & Marketing: Applying agile in cross-functional teams, Continuous integration and delivery (CI/CD), Agile content creation and digital campaigns, Innovation sprints and MVP iterations, Agile in service and product-based industries

UNIT – IV

Managing Teams & Stakeholders in Agile: Team dynamics and conflict resolution, Stakeholder engagement and communication, Agile leadership and servant leadership, Feedback loops and retrospectives, Case examples of agile transformations

UNIT – V

Case Studies: Start-ups and Corporates Using Agile: Case: Spotify, Atlassian, Adobe, Agile success stories from Indian startups, Agile in government and social sectors, Measuring agile maturity, Final group simulation exercise

Text Books:

1. Podeswa, H. (2021). The agile guide to business analysis and planning: From strategic plan to continuous value delivery. Addison-Wesley Professional. ISBN: 9780134191123
2. Evans, A. (2021). The agile innovation playbook: How to develop products better, faster and cheaper. Independently published. ISBN: 9781527279607

Reference Books:

1. Scheer, A.-W. (2023). The composable enterprise: Agile, flexible, innovative. Springer. ISBN: 9783658430894
2. Neumann, M. (2021). The integrated list of agile practices: A tertiary study. arXiv.

Web Links:

1. <https://www.scrum.org/resources/what-is-agile>
2. <https://www.atlassian.com/agile>

Relevant cases have to be discussed in each unit and in examination case study is compulsory from any unit.

INNOVATION AND NEW PRODUCT DEVELOPMENT

	L	T	P	C
Course Code: 2508MS45	2		1	3

Course Outcomes:

At the end of the Course, Student will be able to:

- CO1:** Explain different types of innovation and their strategic impact on market positioning
- CO2:** Apply design thinking and creative ideation techniques for problem-solving and innovation.
- CO3:** Analyze the stages of the new product development process from concept to launch.
- CO4:** Apply prototyping, testing, and iteration techniques to improve product design.
- CO5:** Evaluate commercialization strategies and measure innovation outcomes through relevant metrics

Mapping of Course Outcomes with Program Outcomes:

CO / PO	PO1	PO2	PO3	PO4	PO5	PO6	PO7	PO8
CO1	3	3	3	3	3	3	3	3
CO2	3	3	3	3	3	3	3	3
CO3	3	3	3	3	3	3	3	3
CO4	3	3	3	3	3	3	3	3
CO5	3	3	3	3	3	3	3	3

Mapping of Course Outcomes with Program Specific Outcomes:

CO / PSO	PSO1	PSO2	PSO3
CO1	3	3	3
CO2	3	3	3
CO3	3	3	3
CO4	3	3	3
CO5	3	3	3

UNIT – I

Innovation Types: Incremental vs. Disruptive: Innovation definitions and classifications, Blue Ocean vs. Red Ocean strategies, Market-led vs. technology-led innovation, Examples of disruptive innovations, Building an innovation culture

UNIT – II

Idea Generation Techniques & Design Thinking: Brainstorming and ideation workshops, TRIZ, SCAMPER, and lateral thinking, Introduction to design thinking, Empathy mapping and need finding, Ideation to prototyping journey

UNIT – III

NPD Process: Concept to Launch: Stage-Gate model, Concept testing and feasibility analysis, Business case development, Product development phases, Beta testing and soft launch

UNIT – IV

Prototyping, Testing, and Iteration: Types of prototypes (low-fidelity to high-fidelity), Usability testing methods, Rapid prototyping tools (Figma, Sketch), Feedback loops and iterative improvements, Design validation techniques

UNIT – V

Commercialization & Innovation Metrics: Market launch strategy, Product adoption curve, Metrics: Time to market, ROI on innovation, Risk management and contingency plans, Case studies of successful product launches

Text Books:

1. Trott, P. (2021). Innovation management and new product development (7th ed.). Pearson Education. ISBN: 9781292251523
2. Crawford, C. M., & Di Benedetto, C. A. (2021). New products management (12th ed.). McGraw-Hill Education. ISBN: 9781259911828

Reference Books:

1. Kahn, K. B. (Ed.). (2023). The PDMA handbook of innovation and new product development (4th ed.). Wiley. ISBN: 9781119890218
2. Drotar, D., & Morrissey, D. (2022). Learn & adapt: ExPD – An adaptive product development process for rapid innovation and risk reduction. ExPD Press. ISBN: 9781737832003

Web Links:

1. <https://www.ideo.com/blogs/inspiration/what-is-design-thinking>
2. <https://hbr.org/2015/06/design-thinking-comes-of-age>

Relevant cases have to be discussed in each unit and in examination case study is compulsory from any unit.

MINOR 3: BUSINESS SUSTAINABILITY & LEADERSHIP

SUSTAINABLE BUSINESS MODELS & CIRCULAR ECONOMY

	L	T	P	C
Course Code: 2508MS86	2		1	3

Course Outcomes:

At the end of the Course, Student will be able to:

- CO1:** Explain the fundamentals of sustainability, the Triple Bottom Line, and systems thinking in business.
- CO2:** Apply sustainable business model frameworks like BMC and shared value strategies to real-world scenarios.
- CO3:** Analyze the shift from linear to circular economy principles and their impact on business operations.
- CO4:** Evaluate sector-specific circular economy applications using tools like Life Cycle Assessment (LCA).
- CO5:** Apply global best practices and Indian initiatives to develop sustainability-focused business strategies

Mapping of Course Outcomes with Program Outcomes:

CO / PO	PO1	PO2	PO3	PO4	PO5	PO6	PO7	PO8
CO1	3	3	3	3	3	3	3	3
CO2	3	3	3	3	3	3	3	3
CO3	3	3	3	3	3	3	3	3
CO4	3	3	3	3	3	3	3	3
CO5	3	3	3	3	3	3	3	3

Mapping of Course Outcomes with Program Specific Outcomes:

CO / PSO	PSO1	PSO2	PSO3
CO1	3	3	3
CO2	3	3	3
CO3	3	3	3
CO4	3	3	3
CO5	3	3	3

UNIT – I

Fundamentals of Sustainability in Business: Triple Bottom Line: People, Planet, Profit, UN SDGs and relevance to business, Types of sustainability: economic, environmental, social, Systems thinking in business, Sustainability vs. CSR

UNIT – II

Designing Sustainable Business Models: Business Model Canvas (BMC) for sustainability, Social enterprise models, Inclusive business strategies, Shared value creation, Case studies: Patagonia, Interface

UNIT – III

Principles of Circular Economy: Linear vs. Circular economy, 3Rs and Cradle-to-Cradle design, Industrial symbiosis and reverse logistics, Circular supply chains, Product as a Service (Paas) model

UNIT – IV

Sectoral Applications of Circularity: Circularity in textiles, electronics, food industry, Role of policy and government, SMEs and large corporations: comparative approaches, Life Cycle Assessment (LCA), Green marketing strategies

UNIT – V

Global Best Practices & Indian Context: Leading frameworks: Ellen MacArthur Foundation, ESG-linked investments and ratings, India's initiatives: NITI Aayog, EPR mandates, Sustainable procurement practices, Local business success stories

Text Books:

1. Jonker, J., & Faber, N. (Eds.). (2021). Organizing for sustainability: A guide to developing new business models. Palgrave Macmillan. ISBN: 9783030781569
2. Stefanakis, A., & Nikolaou, I. (Eds.). (2021). Circular economy and sustainability: Volume 1: Management and policy. Elsevier. ISBN: 9780128198179

Reference Books:

1. Liu, L., & Ramakrishna, S. (Eds.). (2021). An introduction to circular economy. Springer Singapore. ISBN: 9789811585098
2. Ritchie, K. J., & Freed, E. C. (2021). Circular economy for dummies. Wiley. ISBN: 9781119716402

Web Links:

1. <https://ellenmacarthurfoundation.org/topics/circular-economy-introduction>
2. <https://niti.gov.in/sustainability-and-circular-economy>

Relevant cases have to be discussed in each unit and in examination case study is compulsory from any unit

ESG METRICS, REPORTING & COMPLIANCE

	L	T	P	C
Course Code: 2508MS35	2		1	3

Course Outcomes:

At the end of the Course, Student will be able to:

- CO1:** Explain the concept of ESG, its components, and its significance in global and Indian business contexts.
- CO2:** Apply ESG reporting frameworks and standards like GRI, SASB, and BRSR for disclosure practices.
- CO3:** Analyze environmental and social metrics related to carbon footprint, waste management, and social audits.
- CO4:** Evaluate governance practices, risk compliance frameworks, and ethical standards in organizations.
- CO5:** Apply ESG tools and case learnings to simulate ESG reporting and investment decision-making.

Mapping of Course Outcomes with Program Outcomes:

CO / PO	PO1	PO2	PO3	PO4	PO5	PO6	PO7	PO8
CO1	3	3	3	3	3	3	3	3
CO2	3	3	3	3	3	3	3	3
CO3	3	3	3	3	3	3	3	3
CO4	3	3	3	3	3	3	3	3
CO5	3	3	3	3	3	3	3	3

Mapping of Course Outcomes with Program Specific Outcomes:

CO / PSO	PSO1	PSO2	PSO3
CO1	3	3	3
CO2	3	3	3
CO3	3	3	3
CO4	3	3	3
CO5	3	3	3

UNIT – I

Introduction to ESG (Environmental, Social, Governance): What is ESG and why it matters?, Components and KPIs, ESG vs. CSR vs. Sustainability, Stakeholder expectations, Global trends and Indian context

UNIT – II

ESG Reporting Frameworks & Standards: GRI, SASB, TCFD, CDP frameworks, BRSR (India-specific), Integrated Reporting (IR), Materiality assessment, ESG disclosures and ratings

UNIT – III

Environmental & Social Metrics: Carbon footprint and GHG inventory, Water and waste management, Social audits: diversity, safety, community engagement, Human rights and labor compliance, Supply chain responsibility

UNIT – IV

Governance & Risk Compliance: Board composition and ethics, Whistle-blower and anti-corruption policies, Data governance and cybersecurity, Risk frameworks and audit mechanisms, Role of legal and compliance officers

UNIT – V

ESG in Practice: Case Studies & Tools: ESG rating agencies (MSCI, Sustainalytics), ESG tools: Enablon, Refinitiv, ESG-linked bonds and funds, Indian case: Infosys, Tata Steel, Group ESG reporting simulation

Text Books:

1. Kumar, S. (2022). Outlast: How ESG can benefit your business. HarperCollins India. ISBN: 9789354892124
2. CFA Institute. (2021). Global ESG Disclosure Standards for Investment Products Handbook. CFA Institute. ISBN: 9781952927057

Reference Books:

1. American Bar Association. (2022). Environmental, social, governance: The professional's guide to the law and practice of ESG. American Bar Association. ISBN: 9781639053292
2. Wendt, K. (2021). Transparency in ESG and the circular economy: Capturing opportunities through data. Business Expert Press. ISBN: 9781637421536

Web Links:

1. <https://www.globalreporting.org/standards>
2. https://www.sebi.gov.in/reports-and-statistics/reports/mar-2021/format-for-business-responsibility-and-sustainability-reporting_49222.html

Relevant cases have to be discussed in each unit and in examination case study is compulsory from any unit.

TRANSFORMATIONAL LEADERSHIP & CHANGE MANAGEMENT

Course Code: 2508MS88	L	T	P	C
	2		1	3

Course Outcomes:

At the end of the Course, Student will be able to:

- CO1:** Explain major leadership theories, styles, and the role of emotional intelligence in leadership effectiveness.
- CO2:** Apply visioning techniques and change leadership models to drive organizational transformation.
- CO3:** Analyze change management frameworks and tools to manage stakeholder expectations and overcome resistance.
- CO4:** Evaluate leadership approaches for managing crises, uncertainty, and organizational resilience.
- CO5:** Apply leadership concepts and skills through real-life case studies, simulations, and a capstone project.

Mapping of Course Outcomes with Program Outcomes:

CO / PO	PO1	PO2	PO3	PO4	PO5	PO6	PO7	PO8
CO1	3	3	3	3	3	3	3	3
CO2	3	3	3	3	3	3	3	3
CO3	3	3	3	3	3	3	3	3
CO4	3	3	3	3	3	3	3	3
CO5	3	3	3	3	3	3	3	3

Mapping of Course Outcomes with Program Specific Outcomes:

CO / PSO	PSO1	PSO2	PSO3
CO1	3	3	3
CO2	3	3	3
CO3	3	3	3
CO4	3	3	3
CO5	3	3	3

UNIT – I

Introduction to Leadership Theories & Styles: Introduction, definition, Leadership Styles Theories, Trait vs. Behavioral theories, Transformational vs. Transactional leadership, Servant and Adaptive leadership, Emotional Intelligence (EI) in leadership, Self-assessment tools and reflection

UNIT – II

Visioning & Driving Organizational Change: Building a compelling vision, Leading change: Kotter’s 8-Step model, Organizational inertia and resistance, Change communication strategies, Role of culture in change

UNIT – III

Change Management Frameworks & Tools: Lewin’s Change Model, McKinsey 7S Framework, Stakeholder analysis and management, Force Field Analysis, Change readiness assessments

UNIT – IV

Leadership in Crisis and Uncertainty: Decision making under pressure, VUCA and BANI environments, Resilience and agility, Crisis communication, Post-pandemic leadership case studies

UNIT – V

Capstone Project & Real-life Leadership Cases: Case: Ratan Tata, Indra Nooyi, Arundhati Bhattacharya, Leadership simulations and role plays, Building leadership philosophy, Measuring leadership impact, Capstone: Real-world leadership challenge

Text Books:

1. Palmer, I., Dunford, R., & Buchanan, D. A. (2022). Managing organizational change: A multiple perspectives approach (4th ed.). McGraw-Hill Education. ISBN: 9781260043716
2. Hayes, J. (2022). The theory and practice of change management (6th ed.). Red Globe Press. ISBN: 9781352012531

Reference Books:

1. Broome, M. E., & Marshall, E. S. (2021). Transformational leadership in nursing: From expert clinician to influential leader (4th ed.). Springer Publishing Company. ISBN: 9780826192547
2. Ausmus, B. (2021). The transformational leadership compass: A dynamic coaching system for creating big change. Lioncrest Publishing. ISBN: 9781544517414

Web Links:

1. <https://hbr.org/topic/leadership>
2. <https://www.mckinsey.com/business-functions/people-and-organizational-performance/our-insights>

Relevant cases have to be discussed in each unit and in examination case study is compulsory from any unit.

MINOR 4: INTERNATIONAL BUSINESS & CROSS-CULTURAL MANAGEMENT

GLOBAL MARKETS & INTERNATIONAL STRATEGY

	L	T	P	C
Course Code: 2508MS39	2		1	3

Course Outcomes:

At the end of the Course, Student will be able to:

- CO1:** Explain globalization trends, trade theories, and the role of global trade organizations.
- CO2:** Apply entry mode strategies and market selection frameworks for international expansion decisions.
- CO3:** Analyze international strategy options including standardization, localization, and global alliances.
- CO4:** Evaluate global supply chain challenges and sustainable logistics practices in international operations.
- CO5:** Apply knowledge of global business trends to simulate the international expansion of an Indian brand.

Mapping of Course Outcomes with Program Outcomes:

CO / PO	PO1	PO2	PO3	PO4	PO5	PO6	PO7	PO8
CO1	3	3	2	2	3	3	3	3
CO2	3	3	3	2	3	3	3	3
CO3	3	3	3	3	3	3	3	3
CO4	3	3	2	3	3	3	3	3
CO5	3	3	3	2	3	3	3	3

Mapping of Course Outcomes with Program Specific Outcomes:

CO / PSO	PSO1	PSO2	PSO3
CO1	3	3	3
CO2	3	3	3
CO3	3	3	3
CO4	3	3	3
CO5	3	3	3

UNIT – I

Introduction to Globalization and Trade Theories: Globalization trends and effects, Absolute, Comparative, Competitive Advantage, Porter’s Diamond Model, Global trade organizations (WTO, IMF, World Bank), FDI vs. FPI

UNIT – II

Entry Modes & Market Selection: Exporting, Franchising, Joint Ventures, Wholly Owned Subsidiaries, Market selection criteria (PESTLE), Country risk analysis, Regional integration (EU, ASEAN, NAFTA), Case examples: IKEA, McDonald's, Tata Motors

UNIT – III

International Strategy Formulation: Standardization vs. Localization, Global strategy vs. Multi-domestic

strategy, Value chain configuration and coordination, Strategic alliances and mergers, Cross-border innovation

UNIT – IV

Global Supply Chain & Logistics: International logistics challenges, Incoterms and international shipping, Supply chain digitization, Risk management in global operations, Sustainable logistics practices

UNIT – V

Global Business Environment and Trends: Geopolitical shifts and trade wars, Currency risks and hedging, Role of technology and e-commerce, Global talent mobility, Final simulation: Expand an Indian brand globally

Text Books:

1. Peng, M. W. (2022). Global strategy (5th ed.). Cengage Learning. ISBN: 9780357516369
2. Ghemawat, P. (2021). Redefining global strategy: Crossing borders in a world where differences still matter (Updated ed.). Harvard Business Review Press. ISBN: 9781633696853

Reference Books:

1. Rugman, A. M., & Verbeke, A. (2021). Global corporate strategy and trade policy (2nd ed.). Routledge. ISBN: 9780367705857
2. Yip, G. S., & Johnson, G. (2021). Strategic transformation and global strategy (2nd ed.). Palgrave Macmillan. ISBN: 9781137593071

Web Links:

1. <https://unctad.org/topic/investment/world-investment-report>
2. https://www.wto.org/english/thewto_e/whatis_e/whatis_e.htm

Relevant cases have to be discussed in each unit and in examination case study is compulsory from any unit.

MANAGING ACROSS CULTURES & BORDERS

Course Code: 2508MS59	L	T	P	C
	2		1	3

Course Outcomes:

At the end of the Course, Student will be able to:

- CO1:** Explain the impact of culture on international business using key cultural frameworks.
- CO2:** Apply cross-cultural communication techniques to manage verbal and non-verbal differences in global contexts.
- CO3:** Analyze the challenges and benefits of managing diversity in global teams, and develop inclusive leadership strategies.
- CO4:** Evaluate expatriate management practices and global HRM strategies across different cultural settings.
- CO5:** Apply intercultural business etiquette principles and real-life case studies to effectively manage global teams and projects.

Mapping of Course Outcomes with Program Outcomes:

CO / PO	PO1	PO2	PO3	PO4	PO5	PO6	PO7	PO8
CO1	3	2	3	3	3	3	3	3
CO2	3	3	3	3	3	3	3	3
CO3	3	3	3	3	3	3	3	3
CO4	3	2	3	3	3	3	3	3
CO5	3	3	3	3	3	3	3	3

Mapping of Course Outcomes with Program Specific Outcomes:

CO / PSO	PSO1	PSO2	PSO3
CO1	3	3	3
CO2	3	3	3
CO3	3	3	3
CO4	3	3	3
CO5	3	3	3

UNIT – I

Culture and Its Impact on Business: Defining culture in international business, Hofstede’s Cultural Dimensions, Trompenaars and Globe studies, Cultural stereotypes vs. realities, Culture shock and adaptation

UNIT – II

Cross-Cultural Communication: Verbal and non-verbal differences, High-context vs. Low-context cultures, Barriers to communication, Cultural intelligence (CQ), Case examples: Negotiating with Chinese, Germans, Americans

UNIT – III

Building Global Teams and Managing Diversity: Advantages of diverse teams, Challenges and conflict resolution, Inclusive leadership, Gender, ethnicity, and generational diversity, DEI policies in corporates

UNIT – IV

Expatriate Management and Global HRM: International assignments lifecycle, Selection, training, and repatriation, Compensation practices, Labor laws across countries, Managing dual-career couples

UNIT – V

Intercultural Business Etiquette & Case Studies: Etiquette in meetings, gift-giving, greetings, Time orientation and punctuality norms, Global negotiation case studies, Cross-cultural marketing case: Dove, Coca-Cola, Role play: Managing a global project team

Text Books:

1. Thomas, D. C., & Peterson, M. F. (2022). Cross-cultural management: Essential concepts (4th ed.). SAGE Publications. ISBN: 9781071819990
2. Browaeyns, M.-J., & Price, R. (2021). Understanding cross-cultural management (4th ed.). Pearson Education. ISBN: 9781292371074

Reference Books:

1. Minkov, M. (2021). Cross-cultural analysis: The science and art of comparing the world's modern societies and their cultures (2nd ed.). SAGE Publications. ISBN: 9781544393871
2. Livermore, D. A. (2020). Leading with cultural intelligence: The real secret to success (3rd ed.). AMACOM. ISBN: 9780814436530

Web Links:

1. <https://geert-hofstede.com/>
2. <https://www.crossculture.com/>

Relevant cases have to be discussed in each unit and in examination case study is compulsory from any unit.

INTERNATIONAL TRADE FINANCE & RISK MANAGEMENT

Course Code: 2508MS49	L	T	P	C
	2		1	3

Course Outcomes:

At the end of the Course, Student will be able to:

- CO1:** Explain the importance and process flow of international trade finance and the role of banks in trade transactions.
- CO2:** Apply various trade payment methods and instruments like letters of credit, bank guarantees, and export credit insurance.
- CO3:** Analyze export incentives and Indian schemes, including MEIS/SEIS and export-friendly policies.
- CO4:** Evaluate foreign exchange risks and apply hedging tools such as forwards, futures, options, and swaps.
- CO5:** Apply trade finance concepts to real-world case studies and prepare export strategies with risk management practices.

Mapping of Course Outcomes with Program Outcomes:

CO / PO	PO 1	PO 2	PO 3	PO 4	PO 5	PO 6	PO 7	PO 8
CO1	3	2	3	3	3	3	3	3
CO2	3	3	3	3	3	3	3	3
CO3	3	2	3	3	3	3	3	3
CO4	3	2	3	3	3	3	3	3
CO5	3	3	3	3	3	3	3	3

Mapping of Course Outcomes with Program Specific Outcomes:

CO / PSO	PSO1	PSO2	PSO3
CO1	3	2	3
CO2	3	3	3
CO3	3	2	3
CO4	3	3	3
CO5	3	3	3

UNIT – I

Overview of International Trade Finance: Importance of trade finance, Process flow of an international trade transaction, IncoTerms and documentation (Invoice, Packing List, Bill of Lading), Banks’ role in trade finance, RBI and EXIM guidelines

UNIT – II

Trade Payment Methods & Instruments: Advance payment, Open account, Collection, LC, Documentary Credit and Letter of Credit (LC), Bank guarantees, UCP 600 and ICC practices, Export credit insurance

UNIT – III

Export Incentives & Indian Schemes: Duty drawback and MEIS/SEIS, EPCG and EOU, ECGC and EXIM Bank, DGFT and other policy institutions, Startup-friendly export initiatives

UNIT – IV

Foreign Exchange Risk & Hedging Tools: Exchange rate movements and types of risk, Forwards, Futures, Options, Swaps, Currency risk management strategies, Hedging through banks and fintechs, Treasury operations basics

UNIT – V

Case Studies and Project Work: Global trade disputes and lessons, India's trade agreements (RCEP, SAFTA), Case: Trade finance in MSMEs, Export plan preparation exercise, Capstone: Risk-managed export strategy

Text Books:

1. Grosse, R. (2022). International business: Theory and practice in the global arena (3rd ed.). Routledge. ISBN: 9780367756774
2. Bhalla, V. K. (2021). International financial management (10th ed.). S. Chand Publishing. ISBN: 9789355011014

Reference Books:

1. Epstein, M. J., & Buhovac, A. R. (2021). Making sustainability work: Best practices in managing and measuring corporate social, environmental, and economic impacts (3rd ed.). Routledge. ISBN: 9780367747642
2. Grath, A. (2021). The handbook of international trade and finance: The complete guide for international sales, finance, shipping and administration (5th ed.). Kogan Page. ISBN: 9781789667457

Web Links:

1. <https://www.eximguru.com/>
2. <https://www.dgft.gov.in/>

Relevant cases have to be discussed in each unit and in examination case study is compulsory from any unit.

**MINOR 5: ENTREPRENEURSHIP & START-UP MANAGEMENT
NEW VENTURE PLANNING & FUNDING MODELS**

Course Code: 2508MS68	L	T	P	C
	2		1	3

Course Outcomes:

At the end of the Course, Student will be able to:

- CO1:** Explain the process of opportunity identification, market validation, and customer feedback loops.
- CO2:** Apply business model frameworks, including the Business Model Canvas, to develop a comprehensive business plan.
- CO3:** Analyze various funding sources and startup capital options, and develop a pitch deck for investment.
- CO4:** Evaluate legal, compliance, and intellectual property requirements for startups, including business registration and regulatory filings.
- CO5:** Apply pitching techniques and investor presentation skills through role plays and simulations.

Mapping of Course Outcomes with Program Outcomes:

CO / PO	PO 1	PO 2	PO 3	PO 4	PO 5	PO 6	PO 7	PO 8
CO1	3	3	2	2	3	2	3	3
CO2	3	3	3	3	3	3	3	3
CO3	3	3	3	3	3	3	3	3
CO4	3	2	3	3	3	2	3	3
CO5	3	3	3	3	3	3	3	3

Mapping of Course Outcomes with Program Specific Outcomes:

CO / PSO	PSO1	PSO2	PSO3
CO1	3	2	3
CO2	3	3	3
CO3	3	3	3
CO4	3	2	3
CO5	3	3	3

UNIT – I

Opportunity Identification & Validation: Problem-solution mapping, Identifying gaps in the market, Market size estimation, Feasibility analysis, Customer interviews and feedback loops

UNIT – II

Business Plan Development: Vision, Mission, and Goals, Business Model Canvas, Operational and Financial Planning, Team structure and role mapping, Risk analysis

UNIT – III

Funding Sources & Startup Capital: Bootstrapping vs. external funding, Angel investors, VCs, Incubators, Government schemes: Startup India, SIDBI, Crowdfunding and equity crowdfunding, Pitch deck essentials

UNIT – IV

Legal, Compliance & IP for Startups: Business registration types (OPC, LLP, Pvt Ltd), Startup India registration, IP basics: Patents, Copyrights, Trademarks, Term sheet and SHA basics, Regulatory filings (MCA, GST)

UNIT – V

Pitching & Final Investor Presentation: Elevator pitch structure, Pitching do's and don'ts, Role play with investors, Peer review and feedback, Final pitch competition simulation

Text Books:

1. Barringer, B. R., & Ireland, R. D. (2022). Entrepreneurship: Successfully launching new ventures (6th ed.). Pearson Education. ISBN: 9781292437152
2. Kuratko, D. F. (2021). Entrepreneurship: Theory, process, and practice (11th ed.). Cengage Learning. ISBN: 9780357033897

Reference Books:

1. Burns, P. (2021). New venture creation: A framework for entrepreneurial start-ups (3rd ed.). Red Globe Press (Macmillan International). ISBN: 9781352012562
2. Gompers, P., & Lerner, J. (2021). Venture capital, private equity, and the financing of entrepreneurship (2nd ed.). Oxford University Press. ISBN: 9780190633912

Web Links:

1. <https://www.startupindia.gov.in>
2. <https://www.investindia.gov.in/startup-india-hub>

Relevant cases have to be discussed in each unit and in examination case study is compulsory from any unit.

LEAN START-UP & MVP STRATEGY

Course Code: 2508MS53

L	T	P	C
2		1	3

Course Outcomes:

At the end of the Course, Student will be able to:

- CO1:** Explain the principles of the Lean Startup methodology and the importance of validated learning and cost-efficient scaling.
- CO2:** Apply MVP design techniques using prototyping tools and test products with early adopters.
- CO3:** Analyze product-market fit and use key metrics to track iterative improvements.
- CO4:** Evaluate growth channels, sales funnels, and scaling strategies for startups.
- CO5:** Apply learnings from real-world case studies to build and pitch an MVP.

Mapping of Course Outcomes with Program Outcomes:

CO / PO	PO 1	PO 2	PO 3	PO 4	PO 5	PO 6	PO 7	PO 8
CO1	3	2	3	3	3	2	3	2
CO2	3	3	3	3	3	3	3	3
CO3	3	3	3	2	3	3	3	3
CO4	3	3	3	3	3	2	3	2
CO5	3	3	3	3	3	3	3	3

Mapping of Course Outcomes with Program Specific Outcomes:

CO / PSO	PSO1	PSO2	PSO3
CO1	3	2	3
CO2	3	3	3
CO3	3	3	3
CO4	3	3	3
CO5	3	3	3

UNIT – I

Lean Start-up Principles: Eric Ries’ Lean Startup Method, Build-Measure-Learn loop, Validated learning and pivots, Cost-efficient scaling, Start-up metrics (LTV, CAC, Burn rate)

UNIT – II

MVP Design & Prototyping: Types of MVPs: Concierge, Landing Page, Explainer Video, Design thinking for MVPs, Prototyping tools: Canva, Figma, Testing with early adopters, Feedback collection

UNIT – III

Product-Market Fit: Defining PMF, Key indicators and surveys (Sean Ellis test), Iterative improvements, Tracking usage metrics, Retention vs. acquisition trade-off

UNIT – IV

Growth Channels & Scaling Strategy: Digital marketing basics, Paid vs. organic channels, Onboarding and referral loops, Sales funnels and conversion rates, Channel fit

UNIT – V

Lean Start-up Case Studies: Dropbox, Airbnb, Zomato, Case comparisons: Lean vs. traditional, MVP analysis project, Final simulation: Build your MVP pitch

Text Books:

1. Blank, S., & Dorf, B. (2020). The startup owner's manual: The step-by-step guide for building a great company (Updated ed.). Wiley. ISBN: 9781119690723
2. Maurya, A. (2022). Running lean: Iterate from plan A to a plan that works (3rd ed.). O'Reilly Media. ISBN: 9781098108774

Reference Books:

1. Ries, E. (2021). The lean startup: How today's entrepreneurs use continuous innovation to create radically successful businesses (10th Anniversary ed.). Crown Business. ISBN: 9780593138138
2. Cooper, B. (2020). The lean entrepreneur: How visionaries create products, innovate with new ventures, and disrupt markets (2nd ed.). Wiley. ISBN: 9781119094996

Web Links:

1. <https://leanstartup.co>
2. <https://www.strategyzer.com>

Relevant cases have to be discussed in each unit and in examination case study is compulsory from any unit.

BUSINESS MODEL INNOVATION & GROWTH HACKING

	L	T	P	C
Course Code: 2508MS14	2		1	3

Course Outcomes:

At the end of the Course, Student will be able to:

- CO1:** Explain various business model frameworks such as the Business Model Canvas and Value Proposition Canvas.
- CO1:** Apply disruptive innovation principles and pivoting strategies to realign business models with market needs.
- CO1:** Analyze growth hacking techniques using AARRR metrics and evaluate the effectiveness of growth loops and viral coefficients.
- CO1:** Evaluate data-driven marketing experiments, including A/B testing and customer segmentation for optimizing funnels.
- CO1:** Apply growth scaling tools, strategies, and metrics to build scalable operations and expand internationally.

Mapping of Course Outcomes with Program Outcomes:

CO / PO	PO 1	PO 2	PO 3	PO 4	PO 5	PO 6	PO 7	PO 8
CO1	3	2	3	3	2	2	3	3
CO2	3	3	3	3	3	3	3	3
CO3	3	3	3	3	2	3	3	3
CO4	3	3	3	3	3	3	3	2
CO5	3	3	3	3	3	3	3	3

Mapping of Course Outcomes with Program Specific Outcomes:

CO / PSO	PSO1	PSO2	PSO3
CO1	3	3	2
CO2	3	3	3
CO3	3	3	3
CO4	3	3	3
CO5	3	3	3

UNIT – I

Business Model Frameworks: Business Model Canvas (BMC), Value Proposition Canvas, Revenue model types, Customer discovery and development, Strategic alignment of model

UNIT – II

Disruptive Innovation & Pivoting Models: Innovator’s Dilemma concepts, Types of pivots: Zoom-in, Zoom-out, Customer Segment, Realignment with market needs, Rapid experimentation culture, Failure as feedback

UNIT – III

Growth Hacking Fundamentals: Origin and definition, AARRR metrics: Acquisition, Activation, Retention, Referral, Revenue, Growth loops vs. funnels, Viral coefficient and retention curves, Tools: Google Analytics, Mixpanel

UNIT – IV

Data-Driven Marketing & Experiments: Customer segmentation and targeting, A/B testing and multivariate testing, Landing page and CTA optimization, Funnels and behavioral analytics, Personalization techniques

UNIT – V

Scaling Up: Tools, Teams & Metrics: Hiring for scale, Building scalable operations, Metrics dashboards, International expansion playbooks, Capstone: Business Model Innovation Challenge

Text Books:

1. Gassmann, O., Frankenberger, K., & Sauer, R. (2021). The business model navigator: 55 models that will revolutionize your business (2nd ed.). Pearson Education. ISBN: 9781292420413
2. Croll, A., & Yoskovitz, B. (2020). Lean analytics: Use data to build a better startup faster (Updated ed.). O'Reilly Media. ISBN: 9781492180748

Reference Books:

1. Osterwalder, A., Pigneur, Y., Bernarda, G., & Smith, A. (2020). The invincible company: How to constantly reinvent your organization with inspiration from the world's best business models. Wiley. ISBN: 9781119523960
2. Holiday, R. (2021). Growth hacker marketing: A primer on the future of PR, marketing, and advertising (Updated ed.). Portfolio. ISBN: 9780593134994

Web Links:

1. <https://strategyzer.com>
2. <https://growthhackers.com>

Relevant cases have to be discussed in each unit and in examination case study is compulsory from any unit.

MANDATORY COURSES

SUSTAINABLE DEVELOPMENT FOR BUSINESS

L T P C

Course Code: 2508AC12

2

Course Outcomes:

At the end of the Course, Student will be able to:

- CO1:** Explain the United Nations Sustainable Development Goals (UN-SDGs).
- CO2:** Apply various Economic, Socio-Political and Ecological aspects of Sustainable Development.
- CO3:** Analyze the relationship between natural resource utilization and sustainable development.
- CO4:** Analyze the Triple Bottom Line (3 BL) approach.
- CO5:** Determine the role of technology in supporting a sustainable future.

Mapping of Course Outcomes with Program Outcomes:

CO / PO	PO 1	PO 2	PO 3	PO 4	PO 5	PO 6	PO 7	PO 8
CO1	3	3	2	3	3	3	3	3
CO2	3	3	3	3	2	3	3	3
CO3	3	3	3	3	3	3	3	3
CO4	3	3	3	3	3	2	3	3
CO5	3	3	3	3	3	3	3	3

Mapping of Course Outcomes with Program Specific Outcomes:

CO / PSO	PSO1	PSO2	PSO3
CO1	3	3	3
CO2	3	3	3
CO3	3	3	3
CO4	3	3	3
CO5	3	3	3

UNIT – I

Introduction to Sustainable Development: Introduction, Meaning, Definition, Historical background, Features and Principles of Sustainable Development, United Nations Sustainable Development Goals (UN-SDGs), Significance and Challenges of Sustainable Development, Sustainability as a key driver of Innovation.

UNIT – II

Aspects of Sustainability Development: Introduction to different aspects of Sustainability Development, Economic Aspects- Meaning, Ways of Achieving Economic Sustainability, Socio-Political Aspects – Meaning, Ways of Achieving Socio-Political Sustainability, Ecological (Environmental) Aspects – Meaning, Ways of Achieving Ecological Sustainability.

UNIT – III

Natural Resources and Sustainable Development: Meaning of Natural Resources, Importance of Natural Resources, Classification of Natural Resources, Natural Resources Utilization and Sustainable

Development, Salient features of The Environment Protection Act 1986, The Water Act 1974, The Air Act 1981, Salient features of Kyoto Protocol from Indian perspective.

UNIT – IV

Sustainable Strategies of Business: Need to adopt sustainable strategy, Triple- bottom line Approach – People, Planet & Profit (3 BL Approach), Various Strategies for Sustainable Development: Community Knowledge, Harness Technology, Innovative Practices, Co- Operation and Partnership, Green Organizations, Corporate Social Responsibility and Corporate Governance.

UNIT – V

New Perspectives Towards Sustainability: Role of technology in supporting sustainable future, Design of products and processes in creating circular business economy, Sustainable products and services and branding and marketing communication, Sustainability Marketing to enhance brand, Collaborations and Partnerships in sustainable development, Green Business Practices.

Text Books:

1. Dopico, L. G., & Rodriguez, C. M. (2021). Sustainable business: Concepts, methodologies, tools, and applications. IGI Global. ISBN: 9781799853481.
2. Crane, A., Matten, D., Glozer, S., & Spence, L. J. (2022). Business ethics: Managing corporate citizenship and sustainability in the age of globalization (6th ed.). Oxford University Press. ISBN: 9780198849964

Reference Books:

1. Schroeder, R. M., & Goldstein, S. M. (2021). Sustainable operations and supply chain management. Wiley. ISBN: 9781119723292
2. Elkington, J. (2020). Green swans: The coming boom in regenerative capitalism. Fast Company Press. ISBN: 9781732439139

Web Links:

- 1 https://onlinecourses.nptel.ac.in/noc21_mg94/preview
- 2 <http://www.iimb.ac.in/18th-podcast-series-sustainability-business>

CORPORATE READINESS-I

Course Code: 2508AC03

L T P C
2

Course Outcomes:

At the end of the Course, Student will be able to:

- CO1:** Make use of online tools for networking and profile building
- CO2:** Develop personal interview and soft skills
- CO3:** Build effective note taking skills
- CO4:** Take part in Group discussion sessions.
- CO5:** Making and delivering presentations.

Mapping of Course Outcomes with Program Outcomes:

CO / PO	PO 1	PO 2	PO 3	PO 4	PO 5	PO 6	PO 7	PO 8
CO1	2	2	2	3	3	1	3	2
CO2	3	2	2	2	2	2	3	3
CO3	2	2	1	1	2	2	2	2
CO4	2	2	2	2	2	2	3	3
CO5	3	2	2	2	2	2	2	3

Mapping of Course Outcomes with Program Specific Outcomes:

CO / PSO	PSO1	PSO2	PSO3
CO1	2	2	2
CO2	3	3	2
CO3	2	2	1
CO4	3	2	2
CO5	3	2	2

UNIT – I

Use Online Tools to Get More Opportunities

Introduce Yourself Professionally:

what is an Elevator pitch

Create an elevator pitch to introduce yourself professionally.

Build Your Personal Brand:

what a personal brand is and why it is important

Elements of a strong personal brand

Ways to build your skills and knowledge, reputation, and values and personality to strengthen your brand

Importance of authenticity in building a personal brand

Online Profile Building:

Importance of a professional online presence

social media tools for professional success

social media netiquette

Unleash the Power of LinkedIn Networking:

Ways to use LinkedIn for career growth

LinkedIn for your job search

LinkedIn to build your personal brand and network with professionals

Mock GD Session**UNIT – II****Prepare for Personal Interview:****Complete Guide to the Interview Process:**

Parts of an interview process

prepare an articulate personal message for interviews

Research industry, companies and interviewer-specific information

Align profiles to the role they are applying for.

Tips for What to do During the Interview:

Appropriate behaviors to adopt before and during an interview

Strategies for effectively navigating a telephonic interview.

What Do You Know About Where You Want to Go?

Key areas of industry awareness

Importance of industry awareness

Interview questions based on industry awareness

How to Ace a Behavioral Interview:

Small talk to set the tone before a formal discussion

Respond to behavioral interview questions,

respond to organization-specific questions using the

Mission-Product/service-culture framework.

How to Answer Competency Based Questions:

Character and competency-based questions

Character based questions on strengths and weaknesses

STAR framework to answer competency-based questions

How to Highlight Your Soft Skills:

Lecture Introduction and Lesson Objectives

Soft skills to highlight during an interview

Respond to questions about time management

Respond to questions about adaptability

Respond to questions about conflict management

Respond to questions about teamwork

Netiquette to Follow for Virtual Interviews and Meetings:

Lecture Introduction and Lesson Objectives

Appropriate netiquette behaviors

What is meant by netiquette

UNIT – III**Note Taking:****Effective Note Taking:**

Lecture Introduction and Lesson Objectives
Importance of note-taking
Process of note-taking
Different strategies for taking notes
Workplace interactions that require note-taking
Online tools for note-taking

Recording Minutes of a Meeting:

Importance of recording minutes in meetings
Best Practices for Recording Minute: gathering necessary documents, creating a template, structuring minutes
Essential Elements of Meeting Minutes

Assessment III:

Quiz
Workbook
Individual Assignment

UNIT – IV**Group Discussions:****Cracking Group Discussions:**

Group Discussions as a Format
Universal Rules for Group Discussions
Strategies to be Heard during Group Discussions
Building on Others' Information
Decorum and Behaviors to Ensure in Group Discussions
Practicing Yourself

Mock GD Sessions**UNIT – V****Make and Deliver a Presentation:**

Using Presentations in a Workplace:
Lecture Introduction and Lesson Objectives
Use of presentations in a workplace
Microsoft PowerPoint Vs Google Slides

Make A Presentation: Planning & Research:

Lecture Introduction and Lesson Objectives
Steps for planning and delivering a presentation
Presentation and slide show

Make A Presentation: Structuring, Drafting and Designing:

Lecture Introduction and Lesson Objectives
what is a Company case study
Drafting a Company Case Study

Lecture Introduction and Lesson Objectives
Steps to follow to fact-check content
What editing and proofreading are
Avoiding plagiarism
Design principles while creating a presentation

Make A Presentation: Practicing As a Group/ Delivering

Lecture Introduction and Lesson Objectives
Strategies for preparing an impactful presentation
Nonverbal communication to enhance your presentation
Speaker notes to present confidently
Strategies for dealing with technical glitches

Text Books:

1. The Business Readiness Levels: Balance skills, manage risk and demonstrate progress with a simple venture benchmark by Mohaimin Chowdhury and Richie Ramsden, ASIN-B07V1VNMYR.
2. 5 Steps to crack Personal Interview: A complete guide to get your dream job by Saurav Bhowmik, ISBN-978-1643244334.

Reference Books:

1. GD Guide, To Excel in Group Discussion by Gyan Shankar, 2019, ISBN:9781797457413
2. Personal Interview Skills by Krishan Kumar ISBN: 978-8193823101

Web links:

1. <https://archive.nptel.ac.in/courses/109/104/109104031/>
2. <https://nptel.ac.in/courses/109105144>

CORPORATE READINESS-II

Course Code: 2508AC04

L T P C
2

Course Outcomes:

At the end of the Course, Student will be able to:

CO1: Apply MSPC, ESEF, STAR frameworks to answer questions in interview.

CO2: Develop confident body language

CO3: Build effective group discussion skills.

CO4: Analyze the importance of organizational culture and values

CO5: Develop time management, Multi-tasking, WLB and EQ skills

Mapping of Course Outcomes with Program Outcomes:

CO / PO	PO 1	PO 2	PO 3	PO 4	PO 5	PO 6	PO 7	PO 8
CO1	3	2	2	2	2	2	3	2
CO2	2	1	3	2	2	2	2	2
CO3	2	2	3	3	2	2	2	3
CO4	2	2	2	3	3	3	2	3
CO5	2	3	2	2	3	3	3	3

Mapping of Course Outcomes with Program Specific Outcomes:

CO / PSO	PSO1	PSO2	PSO3
CO1	3	2	2
CO2	2	2	2
CO3	3	2	2
CO4	2	2	2
CO5	3	2	2

UNIT – I

Practice Personal Interviews:

Mock Interview I:

Lecture Introduction and Lesson Objectives

Practice and prepare for behavioral and character-based questions

Apply the MSPC and ESEF frameworks to answer questions

★ Activity 1

★ Activity 2

Mock Interview II:

Lecture Introduction and Lesson Objectives

Practice and prepare for behavioral questions to highlight your soft skills

Apply the STAR framework to answer questions related to time management, adaptability, teamwork and conflict resolution

★ Activity 1

★ Activity 2

Mock Interview III:

Lecture Introduction and Lesson Objectives

Practice and prepare for curveball questions

Apply reasoning and critical thinking skills to answer whimsical, office situation and brain teaser questions

★ Activity 1

★ Activity 2

UNIT – II**Body Language:****What is Confident Body Language?**

Lecture Introduction and Lesson Objectives

Importance of nonverbal communication

Adopt a confident body language

★ Activity 1

★ Activity 2

How to Appear Confident During Interviews

Lecture Introduction and Lesson Objectives

Do's and don'ts of body language during interviews

Soler framework to maintain good body language during interviews

★ Activity 1

★ Activity 2

The Importance of Grooming:

Lecture Introduction and Lesson Objectives

Essentials of personal grooming

How to be approachable in the workplace

★ Activity 1

★ Activity 2

UNIT – III**Stand Out in Group Discussions****How to Think in Group Discussions:**

Lecture Introduction and Lesson Objectives

What a group discussion entails

Skills needed for an effective group discussion

★ Activity 1

★ Activity 2

How to Speak and Which Roles to Play in a Discussion:

Lecture Introduction and Lesson Objectives

Different roles of participants in a GD

Practice preparing for a GD

★ Activity 1

★ Activity 2

Tips and Tricks to Ace Group Discussions:

Lecture Introduction and Lesson Objectives

Types of Group Discussions (GDs)

Do's and don'ts of participating in GDs

Practice participating in GDs

★ Activity 1

★ Activity 2

Use The Rule of Three:

Lecture Introduction and Lesson Objectives

'Rule of 3' technique

Case Study: Steve Jobs

Rule of 3' to structure a powerful response

★ Activity 1

★ Activity 2

Avoid Thinking Traps:

Lecture Introduction and Lesson Objectives

Common thinking traps and their impact

Strategies to overcome thinking traps

★ Activity 1

★ Activity 2

Overcome the Fight-Flight:

Lecture Introduction and Lesson Objectives

The fight, flight or freeze response

Gibbs' Reflective Cycle

Action plan to overcome the fight, flight or freeze response

★ Activity 1

★ Activity 2

UNIT – IV**Understand Workplaces:****Organizational Culture and Values:**

Lecture Introduction and Lesson Objectives

Organizational culture and its importance

Elements of organizational culture

Connection between organizational culture, values and behavior

★ Activity 1

★ Activity 2

Diversity and Inclusion:

Lecture Introduction and Lesson Objectives

Elements of diversity

Importance of diversity in the workplace

Strategies to adapt to diversity in the workplace

★ Activity 1

★ Activity 2

Situational Awareness:

Lecture Introduction and Lesson Objectives

Steps to follow in case of workplace discrimination

What discrimination and harassment in the workplace look like

- ★ Activity 1
- ★ Activity 2

Thinking like a leader:

Lecture Introduction and Lesson Objectives

Leadership

Theories of leadership

Personal leadership style

- ★ Activity 1
- ★ Activity 2

UNIT – V**Self-Management:****Time Management:**

Lecture Introduction and Lesson Objectives

Online tools that can be used to apply different time management strategies

Different time management strategies and techniques

- ★ Activity 1
- ★ Activity 2

Multitasking and Productivity:

Lecture Introduction and Lesson Objectives

Multitasking and recognize the drawbacks of multitasking

Process of becoming a task opportunist

Ways to become task opportunist effectively

Different apps and tools to become a better task opportunist

- ★ Activity 1
- ★ Activity 2

Manage Stress to Improve Work-life Balance:

Lecture Introduction and Lesson Objectives

Signs of stress and identify triggers

Impact of stress on wellbeing

Action plan to ensure a healthy work-life balance

- ★ Activity 1
- ★ Activity 2

Improve EQ and Manage Emotions:

Lecture Introduction and Lesson Objectives

Meaning and importance of having high emotional quotient in the workplace

Differentiate between emotional quotient and intelligence quotient

How to foster healthy relationships in the workplace for stronger communication

- ★ Activity 1
- ★ Activity 2

Text Books:

1. The Business Readiness Levels: Balance skills, manage risk and demonstrate progress with a simple venture benchmark by Mohaimin Chowdhury and Richie Ramsden, ASIN-B07V1VNMYR.
2. 5 Steps to crack Personal Interview: A complete guide to get your dream job by Saurav Bhowmik, ISBN-978-1643244334.

Reference Books:

1. GD Guide, To Excel in Group Discussion by Gyan Shankar, 2019,ISBN-13:978-1797457413.
2. Self-Awareness By Harvard Business Review, Daniel Goleman, Robert Steven Kaplan, Susan David, Tasha Eurich, ISBN:978-1633696617

Web links:

1. <https://archive.nptel.ac.in/courses/109/104/109104031/>
2. <https://nptel.ac.in/courses/109105144>

CORPORATE READINESS-III

L T P C
2

Course Code: 2508AC05

Course Outcomes:

At the end of the Course, Student will be able to:

- CO1:** Analyze the role team work and collaboration
- CO2:** Build trust, credibility and professional network.
- CO3:** Distinguish between different types of arguments.
- CO4:** Evaluate the role of emotional intelligence at work place.
- CO5:** Develop self-awareness and skill identification.

Mapping of Course Outcomes with Program Outcomes:

CO / PO	PO 1	PO 2	PO 3	PO 4	PO 5	PO 6	PO 7	PO 8
CO1	2	2	3	2	2	3	2	3
CO2	2	2	2	2	2	3	2	3
CO3	3	3	2	2	1	2	1	2
CO4	2	2	3	2	3	3	2	3
CO5	2	3	3	2	3	2	2	3

Mapping of Course Outcomes with Program Specific Outcomes:

CO / PSO	PSO1	PSO2	PSO3
CO1	3	2	2
CO2	2	2	2
CO3	3	2	2
CO4	2	2	2
CO5	3	3	2

UNIT – I

Understand Teamwork:

Teamwork:

- Lecture Introduction and Lesson Objectives
- Skills required for teamwork
- Different roles people can play in a team
- Importance of teamwork
- ★ Activity 1
- ★ Activity 2

Advanced Conflict Resolution Strategies:

- Lecture Introduction and Lesson Objectives
- Common workplace conflicts and identify the causes behind them
- Role of collaboration in handling conflicts
- Strategies for enabling collaboration
- ★ Activity 1

★ Activity 2

Collaborate With Others:

Lecture Introduction and Lesson Objectives

Conflict and its causes

Three approaches of handling conflict

★ Activity 1

★ Activity 2

Give And Receive Feedback:

Lecture Introduction and Lesson Objectives

Process of feedback

Giving constructive feedback

How to receive feedback positively

Create a development plan based on the feedback received

★ Activity 1

★ Activity 2

UNIT – II

Prepare for the Workplace:

Build Trust & Credibility:

Lecture Introduction and Lesson Objectives

Elements of trust

Self-assess and reflect on your own trustworthiness

Reflect on people you find trustworthy using the BRAVING framework

★ Activity 1

★ Activity 2

Build Your Professional Networks:

Lecture Introduction and Lesson Objectives

How professional networking helps in building trust

Practices to build trust

The seven-step process to mend broken trust

★ Activity 1

★ Activity 2

Learn The Art of Small Talk:

Lecture Introduction and Lesson Objectives

Importance of making small talk at the workplace

Strategies for making small talk meaningful

Techniques for overcoming your hesitation when initiating small talk

★ Activity 1

★ Activity 2

Practice Small Talk in Professional Spaces:

Lecture Introduction and Lesson Objectives

Small talk is and its benefits

Do's and don'ts for practicing small talk

Small talk in different professional spaces

- ★ Activity 1
- ★ Activity 2

UNIT – III

Logical Arguments:

Lecture Introduction and Lesson Objectives

Identify an argument and its parts

Structure sound arguments

Identify logical fallacies

Structure an argument by applying logic

- ★ Activity 1
- ★ Activity 2

Types of Arguments:

Lecture Introduction and Lesson Objectives

Deductive and inductive arguments in workplace scenarios

Written argument: a position, reasons, evidence, counter-argument

Situations where you have to use written arguments in the workplace and see examples of written arguments

- ★ Activity 1
- ★ Activity 2

Evidence and Biases:

Lecture Introduction and Lesson Objectives

Differentiate between facts and opinions

Strategies to avoid bias in written arguments

Authenticity of evidence

- ★ Activity 1
- ★ Activity 2

Critically Evaluating Arguments:

Lecture Introduction and Lesson Objectives

Differentiate between strong and weak arguments through a group activity

Untangle arguments using different techniques

Use effective argumentation techniques to build convincing skills

- ★ Activity 1
- ★ Activity 2

Overcoming Biases:

Lecture Introduction and Lesson Objectives

Biases and their effect on thinking

Internally held and externally experienced biases

Debiasing techniques to develop unbiased thinking

Responding appropriately to externally experienced biases

- ★ Activity 1
- ★ Activity 2

UNIT – IV

Emotional Intelligence:

Empathy at work:

Lecture Introduction and Lesson Objectives

What is empathy

Scenarios where you need to show empathy

Blockers to empathy

Showing empathy at the workplace

★ Activity 1

★ Activity 2

Compassion and gratitude:

Lecture Introduction and Lesson Objectives

Importance of showing compassion and discuss ways of demonstrating it

Differentiate between gratitude and appreciation and discuss the impact of both

Practice showing gratitude

★ Activity 1

★ Activity 2

UNIT – V

Self-Awareness:

Learning strategies:

Lecture Introduction and Lesson Objectives

Different types of intelligences

Learning styles and identify strategies that you can use to enhance your learning

Obstacles to learning and create a plan of action to enhance productivity

★ Activity 1

★ Activity 2

Self-awareness - skill identification:

Lecture Introduction and Lesson Objectives

Differentiate between emotional quotient and intelligence quotient and the impact of each of them

What it means to be self-aware

Johari Window Model to cultivate self-awareness

★ Activity 1

★ Activity 2

Motivating self and others:

Lecture Introduction and Lesson Objectives

Components of motivation

‘BREAK’ approach to improve your motivation

Importance of motivation and its theories

Differentiate between intrinsic and extrinsic motivation

★ Activity 1

★ Activity 2

Addressing an Audience with Confidence: Part 1

Lecture Introduction and Lesson Objectives
Purpose and importance of confidence
Ways to show confidence through body language

Practice Jam Session to boost confidence

- ★ Activity 1
- ★ Activity 2

Addressing an Audience with Confidence: Part 2

Lecture Introduction and Lesson Objectives
Purpose and importance of public speaking
Ways to address audience during public speaking
Practice public speaking through class activity

- ★ Activity 1
- ★ Activity 2

Text Books:

1. The Business Readiness Levels: Balance skills, manage risk and demonstrate progress with a simple venture benchmark by Mohaimin Chowdhury and Richie Ramsden, ASIN-B07V1VNMYR.
2. The Emotionally Intelligent Team: Building Collaborative Groups that Outperform the Rest by Vanessa Urch Druskat, ASIN-B0C9N3W9Q5

Reference Books:

1. Establishing Trust and Credibility by Timothy F. Bednarz , Majorium Business Press, ASIN: B00HRFZ93Y
2. Self-Awareness By Harvard Business Review, Daniel Goleman, Robert Steven Kaplan, Susan David, Tasha Eurich, ISBN: 978-1633696617

Web links:

1. https://onlinecourses.nptel.ac.in/noc23_mg123/preview
2. https://onlinecourses.nptel.ac.in/noc20_hs13/preview

APTITUDE TRAINING

Course Code: 2508AC01

L T P C
2

Course Outcomes:

At the end of the Course, Student will be able to:

- CO1:** Gain conceptual knowledge about the number system and Use mathematical concepts to calculate fractions, averages, and ratios.
- CO2:** Apply mathematical skills to interpret data and draw conclusions
- CO3:** Use mathematical and logical reasoning skills to solve problems efficiently
- CO4:** Use percentage shortcuts to calculate profit, loss, and interest
- CO5:** Practice advanced quantitative problem-solving to solve questions

Mapping of Course Outcomes with Program Outcomes:

CO / PO	PO 1	PO 2	PO 3	PO 4	PO 5	PO 6	PO 7	PO 8
CO1	3	3	2	1	1	1	2	1
CO2	3	3	3	2	1	1	2	2
CO3	3	3	3	2	1	1	2	2
CO4	3	3	2	2	1	1	1	2
CO5	3	3	3	2	1	1	2	2

Mapping of Course Outcomes with Program Specific Outcomes:

CO / PSO	PSO1	PSO2	PSO3
CO1	3	2	2
CO2	3	3	2
CO3	3	3	2
CO4	3	2	2
CO5	3	3	2

UNIT – I

Fundamentals of Mathematics:

Numerical Ability: Introduction to Number System, HCF, and LCM, Types of numbers, conversion of numbers, Prime factorization, Finding HCF and LCM using prime factorization, Euclid algorithm, word problems.

Number Series I: Basic number series, Basic arithmetic progression questions, Arithmetic and geometric progression, mixed series questions, Word problems based on both concepts

Fractions and Averages: Applications of averages in real-life scenarios, Types of fractions, Operations on Fractions, Conversion of fractions to decimals and percentages, Word problems involving fractions and averages

Ratio and Proportion: Compound ratio and combined ratio, Meaning of proportion, Word problems on ratios.

UNIT – II

Percentages, Profit and Loss, SI and CI:

Percentages: Converting percentages to fractions and decimals, Percentage increase and decrease, Application of percentages real-life scenarios.

Profit and Loss: Meaning of terms and formulae, Relationship between various variables, Discounts, Successive discount, Word problems. **Simple and Compound Interest:** Meaning of interest, the formula for SI and CI, Word problems.

UNIT – III

Data Interpretations, Permutation and Combination:

Data Interpretation I: Questions based on Bar graphs, line graphs, tables and pie chart.

Data Interpretation II: Double and triple bar graphs questions, Double pie chart questions, Questions based on profit and loss, and multiple tables.

Permutation and Combination: Finding the number of permutations of n objects taken r at a time, Circular permutation, Application of permutation in real-life scenarios, finding the number of combinations of n objects taken r at a time, Application of combination in real-life scenarios.

Probability: Meaning and formula of probability, questions based on coins, lottery tickets, cards.

UNIT – IV

Quantitative Problem Solving:

Time and Work: Inverse principle, word problems based on this topic.

Speed, Distance and Time: Inverse principle, word problems based on this topic, Relationship between speed, distance and time, Average speed and relative speed, Word problems based on train.

Boat and Streams, Train Problems: Relative speed, Upstream and downstream concept, Problems based on two trains.

Numerical Methods: Basic concepts of mixtures and alligations, Types of mixtures, Alligations method, Applications of this topic in real life, Word problems.

Pipes and Cisterns: Work done by pipes and cisterns, Pipes and cisterns problems involving filling and emptying the tank, Pipes and cisterns problems involving different rates of filling and emptying, Problems involving two or more pipes and cisterns working together.

UNIT – V

Mathematical Reasoning and Logical Reasoning:

Calendar: Leap year, day and date, repeated years, and exact day

Arithmetic Reasoning: Questions based on basic mathematical reasoning which includes the number of legs or heads, sharing between friends, number of routes.

Analogy and Odd One Out: Meaning of Analogy, Questions based on numbers and words, Meaning of odd one out, Questions based on words and numbers.

Directions and Coding-decoding: Direction graph, Questions based on Pythagoras theorem, angles, and shadow, Letter, number and substitution coding.

Coded Inequalities: Meaning of inequality, Statement and conclusion-based questions.

Blood Relations: Family tree, Coded blood relations, Questions based on photographs

Text Books:

1. Quantitative Aptitude for Competitive Examinations by RS Aggarwal, ISBN-13:978-9355012326.
2. Quantitative Aptitude for Competitive Examination by Abhijit Guha, ISBN-13:978-9389811544.

Reference Books:

1. Text Book of Quickest Mathematics: Quantitative Aptitude & Numerical Ability Useful for all Competitive Exams by Kiran Prakashan, ISBN-13:978-9390797363.
2. Quantitative Aptitude for Comprehension by Trisha Knowledge System, ISBN-13:978-9353063047.

Web Links:

1. <https://www.coursera.org/learn/quantitative-foundations-international-business>
2. <https://www.coursera.org/learn/mathematical-thinking>

DESIGN THINKING AND INNOVATION

Course Code: 2508AC06

L T P C
2

Course Outcomes:

At the end of the Course, Student will be able to:

- CO1:** Explain the core concepts and historical evolution of Design Thinking.
- CO2:** Apply empathy research methods to gather user insights and create problem statements and journey maps.
- CO3:** Analyze ideation techniques and develop prototypes using various tools.
- CO4:** Evaluate user feedback and implement iterative design improvements.
- CO5:** Examine the principles and processes of innovation and differentiate between types of innovation.

Mapping of Course Outcomes with Program Outcomes:

CO / PO	PO 1	PO 2	PO 3	PO 4	PO 5	PO 6	PO 7	PO 8
CO1	3	2	2	2	2	2	3	1
CO2	2	3	2	3	2	3	2	2
CO3	2	2	2	3	2	3	3	2
CO4	2	2	2	3	2	3	3	3
CO5	3	2	2	2	2	3	2	2

Mapping of Course Outcomes with Program Specific Outcomes:

CO / PSO	PSO1	PSO2	PSO3
CO1	2	2	2
CO2	2	3	2
CO3	2	3	2
CO4	2	3	2
CO5	3	2	2

UNIT – I

Design Thinking: Definition, Historical background and evolution, Benefits, Applications of Design Thinking; The Design Thinking Process (Empathize, Define, Ideate, Prototype, and Test), Cultivating creativity, empathy, and problem-solving skills.

UNIT – II

Empathy Research Methods: Interviews, observations, and user personas, Understanding User Needs: Techniques for gathering and analyzing user insights.

Problem Definition: Framing and articulating the problem statement. Journey Mapping: Visualizing user experiences and identifying pain points. (Tools and Techniques: Empathy maps, user journey maps, and personas.)

UNIT – III

Ideation Techniques: Brainstorming, mind mapping, SCAMPER, and role-playing. Encouraging Creativity: Techniques to foster an innovative mindset.

Prototyping Methods: Low-fidelity and high-fidelity prototypes, wireframes, and mock-ups. Rapid Prototyping: Iterative development and testing of prototypes. (Tools and Resources: Prototyping tools and software; e.g., Sketch, InVision, Figma)

UNIT – IV

User Testing Methods: Usability testing, A/B testing, and feedback loops. Gathering and Analyzing Feedback: Techniques for collecting and interpreting user feedback. Iterative Design: Refining solutions based on user feedback and testing results.

Implementation Strategies: Planning and executing the rollout of new solutions.

UNIT – V

Innovation: -Meaning, Concept, Characteristics, Importance, Principles of Innovation, Process of Innovation, Factors Influencing Innovation, Types of innovation (incremental, disruptive, open, and radical)

Text Books:

1. Liedtka, J., Salzman, R., & Azer, D. (2021). Design thinking for the greater good: Innovation in the social sector (2nd ed.). Columbia University Press. ISBN: 9780231195685.
2. Brown, T., & Martin, R. (2021). Design thinking: Integrating innovation, customer experience, and brand value. Harvard Business Review Press. ISBN: 9781647822242.

Reference Books:

1. Kelley, T., Kelley, D., & Littman, J. (2022). Creative confidence: Unleashing the creative potential within us all. Currency. ISBN: 9780385349369
2. Cambridge Design Partnership. (2023). Design thinking for innovation: A practical guide for business leaders. Routledge. ISBN: 9781032370172.

Web Links:

1. https://onlinecourses.nptel.ac.in/noc22_mg32/preview
2. https://onlinecourses.swayam2.ac.in/imb23_mg65/preview

BUSINESS MANAGEMENT TOOLS

Course Code: 2508AC02

L T P C
2

Course Outcomes:

At the end of the Course, Student will be able to:

- CO1:** Utilize business management tools effectively to improve organizational efficiency.
- CO2:** Develop proficiency in using G-Suite applications for streamlined collaboration and productivity.
- CO3:** Manage documents and PDFs efficiently to enhance document organization and accessibility.
- CO4:** Enhance productivity through the use of Excel shortcuts and advanced functions for data analysis.
- CO5:** Gain practical knowledge in SQL fundamentals and Power BI for effective data retrieval and visualization in business intelligence.

Mapping of Course Outcomes with Program Outcomes:

CO / PO	PO 1	PO 2	PO 3	PO 4	PO 5	PO 6	PO 7	PO 8
CO1	3	2	2	2	2	3	3	2
CO2	2	2	2	2	2	2	3	2
CO3	2	2	2	2	2	2	2	2
CO4	3	3	2	2	2	3	3	2
CO5	3	3	3	2	2	3	3	2

Mapping of Course Outcomes with Program Specific Outcomes:

CO / PSO	PSO1	PSO2	PSO3
CO1	2	2	3
CO2	2	2	3
CO3	2	1	2
CO4	2	3	3
CO5	3	3	3

UNIT – I

Introduction to Business Management Tools: Business management tools – types, relevance in modern operations, Role in enhancing productivity, efficiency, decision-making, Adobe Tools – overview, applications, key features, Microsoft Suite – Word, Excel, PowerPoint, Outlook, business uses.

UNIT – II

G-Suite – overview, applications, invites, calendar settings, Google Docs – creating, formatting, using templates, Google Slides – presentation design, slide formatting, Google Sheets – data entry, formulas, formatting, advanced features.

UNIT – III

Document and PDF Management: PDF tools – merging, compressing using various software, PDF editing – text, images, annotations, editing tools.

UNIT – IV

Excel Shortcuts and Advanced Functions: Excel shortcuts – productivity tips, quick navigation, Advanced functions – VLOOKUP, SUMIF, COUNTIF, business data analysis.

UNIT – V

SQL Fundamentals: SQL – basics, creating tables, writing queries, Power BI – data connections, visualizations, interactive dashboards.

Text Books:

Pandey, I. M., & Bhatt, R. (2021). Cases in financial management: Business decision making tools and techniques (2nd ed.). McGraw-Hill Education. ISBN: 9789354600455.

Harrison, J. S., & St. John, C. H. (2021). Foundations in strategic management (8th ed.). Cengage Learning. ISBN: 9780357516345

Reference Books:

Rothaermel, F. T. (2023). Strategic management (5th ed.). McGraw-Hill Education. ISBN: 9781266142750

Harvard Business Review. (2022). HBR's 10 must reads on business strategy (Vol. 2). Harvard Business Review Press. ISBN: 9781647823416.

Web Links:

1. <https://nptel.ac.in/courses/110105083>
2. <https://gsstech.in/wp-content/uploads/2024/07/PowerBi-Curriculum-1.pdf>

INTELLECTUAL PROPERTY RIGHTS

Course Code: 2508AC10

L T P C
2

Course Outcomes:

At the end of the Course, Student will be able to:

- CO1:** Compare different IP laws and need for protecting IP
- CO2:** Explain different theories on the concept of property
- CO3:** Identify various functions of WIPO
- CO4:** Analyze the IP laws in India
- CO5:** Differentiate various forms of IPR

Mapping of Course Outcomes with Program Outcomes:

CO / PO	PO 1	PO 2	PO 3	PO 4	PO 5	PO 6	PO 7	PO 8
CO1	2	2	2	3	3	2	2	2
CO2	2	3	2	2	2	2	1	2
CO3	2	2	2	2	3	2	2	2
CO4	3	3	2	3	3	2	2	3
CO5	3	3	2	3	2	2	2	2

Mapping of Course Outcomes with Program Specific Outcomes:

CO / PSO	PSO1	PSO2	PSO3
CO1	2	2	2
CO2	2	2	1
CO3	2	2	2
CO4	3	2	2
CO5	3	2	2

UNIT – I

Introduction: Origin and Development of IPR – Historical and theoretical basis for protection of IPR – Analyzing and understanding the Interpretation of IP laws – Need for Protecting IP

UNIT – II

Concept of Property: Theories on concept of property – Nature – Public Vs. Private – Tangible Vs. Intangible – Industrial Vs. Intellectual

UNIT – III

International IP Regime: World Intellectual Property Organization (WIPO) – Functions of WIPO – Membership – GATT Agreement – Major Conventions on IP – Berne Convention – Paris Convention – TRIPS agreement.

UNIT – IV

Indian IP Regime: Overview of IP laws in India – Major IP Laws in India – International treaties signed by India. IPR and Constitution of India.

UNIT – V

Forms of IPR: Forms of IPR – Copyright – Trademark – Patents – Industrial Designs – Trade Secrets – Geographical Indications - Application of different forms of IPR.

Text Books:

1. Neeraj Pandey, Khushdeep Dharni , Intellectual Property Rights. (2021), PHI Learning Pvt. Ltd. ISBN: 9789390544335
2. Deborah E. Bouchoux (2021) Intellectual Property: The Law of Trademarks, Copyrights, Patents, and Trade Secrets" (2021) Cengage Learning, ISBN: 9780199645558

Reference Books:

1. Lionel Bently, Brad Sherman, Intellectual Property Law, 5th Edition (2022 Reprint) Oxford University Press ISBN: 9780199645558.
2. V. K. Ahuja , Law Relating to Intellectual Property Rights, LexisNexis publisher, 3rd Edition (2022) ISBN: 9789391211786

Web Links:

- 1 https://onlinecourses.nptel.ac.in/noc22_hs59/preview
- 2 <https://archive.nptel.ac.in/courses/110/105/110105139/>

PROJECT MANAGEMENT

Course Code: 2508AC11

L T P C
2

Course Outcomes:

At the end of the Course, Student will be able to:

- CO1:** Explain the basic concepts of project Management
- CO2:** Estimate project planning and risk.
- CO3:** Interpret project financing through techniques
- CO4:** Analyze the concept of Project controlling
- CO5:** Summarize stress management, conflict management and team building

Mapping of Course Outcomes with Program Outcomes:

CO / PO	PO 1	PO 2	PO 3	PO 4	PO 5	PO 6	PO 7	PO 8
CO1	3	2	2	2	2	2	2	2
CO2	2	3	2	3	2	2	2	2
CO3	3	3	2	2	2	2	2	2
CO4	2	3	2	2	2	2	3	2
CO5	2	2	3	2	3	3	2	3

Mapping of Course Outcomes with Program Specific Outcomes:

CO / PSO	PSO1	PSO2	PSO3
CO1	3	2	2
CO2	3	3	2
CO3	2	3	2
CO4	2	2	2
CO5	2	2	3

UNIT – I

Introduction to Project Management: Project Characteristics – Project Life Cycle – Project Identification, Formulation and Implementation – Project Management in Different Sectors: Construction, Services Sector, Public Sector and Government Projects. Systems Approach to Project Management.

UNIT – II

Project Appraisal: Project Planning – Steps in Project Planning – Scheduling – Project Appraisal – Feasibility Study – Technical, Commercial, Economic, Financial, Management, Social Cost Benefit Analysis – Project Risk Analysis

UNIT – III

Project Finance: Project Cost Estimation, Project Financing – Investment Criteria, Project Evaluation Techniques – Pay Back Period, Accounting Rate of Return, Net Present Value, Internal Rate of Return, Profitability Index, Cash Flows Estimation for New and Replacement Projects – Cost of Capital, Risk Analysis.

UNIT – IV

Project Control: Network Diagrams, Network Analysis, Critical Path, Quality Management, Project Execution, Monitoring and Control, Agile Project Management, Scrum, Lean Production and Project Management.

UNIT – V

Organizational Behavior and Project Management: Organizational Structure and Integration, Role of Project Manager, Roles in the Project Team, Project Stakeholder Engagement, Leadership in Project Management, Participative Management, Team Building Approach, Conflict Management in Projects, Stress Management.

Text Books:

1. Larson, E. W., & Gray, C. F. (2021). Project management: The managerial process (8th ed.). McGraw-Hill Education. ISBN: 9781260736207.
2. Pinto, J. K. (2022). Project management: Achieving competitive advantage (6th ed.). Pearson Education. ISBN: 9781292436483

Reference Books:

1. Project Management Institute. (2021). A guide to the project management body of knowledge (PMBOK® Guide) (7th ed.). Project Management Institute. ISBN: 9781628256642
2. Meredith, J. R., Shafer, S. M., & Mantel, S. J. (2021). Project management: A managerial approach (10th ed.). Wiley. ISBN: 9781119803772

Web Links:

1. https://onlinecourses.nptel.ac.in/noc23_mg124/preview
2. https://onlinecourses.nptel.ac.in/noc24_mg01/preview

EMPLOYABILITY SKILLS-1

Course Code: 2508AC07

L T P C
2

Course Outcomes:

At the end of the Course, Student will be able to:

- CO1:** Apply fundamental arithmetic concepts such as number systems, LCM & HCF, ratio & proportion, and averages to solve quantitative problems efficiently.
- CO2:** Analyze number and letter series to identify logical patterns and predict subsequent elements.
- CO3:** Select the option by evaluating relationships in analogy-based problems and detecting inconsistencies in logical sequences
- CO4:** Demonstrate effective verbal communication skills by using appropriate parts of speech and tone in various interpersonal and professional contexts.

Mapping of Course Outcomes with Program Outcomes:

CO \ PO	PO1	PO2	PO3	PO4	PO5	PO6	PO7	PO8
CO1	3	2	–	–	–	–	–	–
CO2	–	3	2	–	–	–	–	–
CO3	–	3	3	–	1	–	–	–
CO4	–	–	–	3	–	2	–	2

Mapping of Course Outcomes with Program Specific Outcomes:

CO \ PSO	PSO1	PSO2	PSO3
CO1	2	2	–
CO2	2	3	–
CO3	–	2	3
CO4	–	–	3

Aptitude:

Number System, LCM & HCF, Ratio and Proportion, Averages

Reasoning:

Number Series, Letter Series, Number Analogy, Letter Analogy, Odd Man Out, Logical Sequence of Words.

Verbal:

Introduction to soft skills, how to improve communication? Parts of Speech, Mind your language towards better English, Vocabulary Expansion

Text Books:

1. Dr. R. S. Aggarwal, Quantitative Aptitude for Competitive Examinations , S. Chand

Publishing, ISBN: 978-9352534029

2. Dr. R. S. Aggarwal, A Modern Approach to Verbal and Non-Verbal Reasoning, S. Chand Publishing, ISBN: 978-9352832163

Reference Books:

1. Dr. R. S. Aggarwal, Vikas Aggarwal, Quick Learning Objective General English, S. Chand Publishing, ISBN: 978-9352837564
2. Abhijit Guha, Quantitative Aptitude for Competitive Examinations, McGraw-Hill Education, ISBN: 978-9353160180
3. M. K. Pandey, Analytical Reasoning, Arihant Publications, ISBN: 978- 9350947982

Web Links:

1. www.indiabix.com
2. www.bankersadda.com

EMPLOYABILITY SKILLS- II

L T P C

Course Code: 2508AC08

2

Course Outcomes:

At the end of the Course, Student will be able to:

- CO1:** Apply percentage, profit & loss, and partnership concepts to solve real-world quantitative problems.
- CO2:** Analyze age-related problems to develop logical problem-solving strategies.
- CO3:** Evaluate logical reasoning questions including ranking, directions, and alphabet tests for accurate decision-making.
- CO4:** Solve pattern-based problems in coding and decoding to enhance analytical skills.
- CO5** Demonstrate effective written communication using correct grammar and structured presentation techniques

Mapping of Course Outcomes with Program Outcomes:

CO \ PO	PO1	PO2	PO3	PO4	PO5	PO6	PO7	PO8
CO1	3	2	–	–	–	–	–	–
CO2	–	3	2	–	–	–	–	–
CO3	–	3	3	–	1	–	–	–
CO4	–	2	3	–	–	–	–	–
CO5	–	–	–	3	–	2	–	2

Mapping of Course Outcomes with Program Specific Outcomes:

CO \ PSO	PSO1	PSO2	PSO3
CO1	2	2	–
CO2	2	3	–
CO3	–	2	3
CO4	–	2	2
CO5	–	–	3

Aptitude:

Problems on Ages, Partnership, Percentages, Profit and Loss

Reasoning:

Coding and Decoding, Ranking Test, Alphabet Test, Direction Test

Verbal:

Written communication skill practice, Grammatical use, Concept of 4 step method for presentation, Present Tense

Text Books:

1. Dr. R. S. Aggarwal, Quantitative Aptitude for Competitive Examinations, S. Chand Publishing, ISBN: 978-9352534029
2. Dr. R. S. Aggarwal, A Modern Approach to Verbal and Non-Verbal Reasoning, Publication: S. Chand Publishing, ISBN: 978-9352832163

Reference Books:

1. Dr. R. S. Aggarwal, Vikas Aggarwal, Quick Learning Objective General English , S.Chand Publishing, ISBN: 978-9352837564
2. Abhijit Guha, Quantitative Aptitude for Competitive Examinations, McGraw Hill Education, ISBN: 978-9353160180
3. M. K. Pandey, Analytical Reasoning , Arihant Publications, ISBN: 978-9350947982

Web Links:

1. www.indiabix.com
2. www.bankersadda.com

EMPLOYABILITY SKILLS-III

Course Code: 2508AC09

L T P C
2

Course Outcomes:

At the end of the Course, Student will be able to:

- CO1:** Solve financial and quantitative aptitude problems using concepts of simple and compound interest.
- CO2:** Apply logical time-work frameworks to solve real-time problems related to work efficiency and pipe systems.
- CO3:** Analyze and interpret problems related to blood relations, clocks, calendars, and coded inequalities.
- CO4:** Evaluate spatial and logical reasoning through cubes, dice, and symbolic interpretation problems.
- CO5:** Demonstrate effective communication using correct grammar, and participate actively in discussions and comprehension activities.

Mapping of Course Outcomes with Program Outcomes:

CO \ PO	PO1	PO2	PO3	PO4	PO5	PO6	PO7	PO8
CO1	3	2	–	–	–	–	–	–
CO2	2	3	2	–	–	–	–	–
CO3	–	3	3	–	1	–	–	–
CO4	–	2	3	–	–	–	–	–
CO5	–	–	–	3	–	2	–	2

Mapping of Course Outcomes with Program Specific Outcomes:

CO \ PSO	PSO1	PSO2	PSO3
CO1	2	2	–
CO2	2	3	–
CO3	–	2	3
CO4	–	2	2
CO5	–	–	3

Aptitude:

Simple Interest, Compound Interest, Time and Work, Pipes and Cisterns

Reasoning:

Blood Relations, Calendar, Clocks, Cubes and Dice, Coded Inequalities

Verbal:

Grammar in use, Group discussion, Reading Comprehension, Past Tense, Future Tense

Text Books:

1. Dr. R. S. Aggarwal, Quantitative Aptitude for Competitive Examinations, S. Chand Publishing, ISBN:

978-9352534029

2. Dr.R.S.Aggarwal, A Modern Approach to Verbal and Non-Verbal Reasoning, S. Chand Publishing, ISBN: 978-9352832163

Reference Books:

1. Dr. R. S. Aggarwal, Vikas Aggarwal, Quick Learning Objective General English ,S. Chand Publishing, ISBN: 978-9352837564
2. AbhijitGuha, Quantitative Aptitude for Competitive Examinations, McGrawHill Education, ISBN: 978-9353160180
3. M.K.Pandey, Analytical Reasoning Arihant Publications, ISBN: 978-9350947982

Web Links:

1. www.indiabix.com
2. www.bankersadda.com