

PROGRAM CURRICULUM

MASTER OF BUSINESS ADMINISTRATION

for

MASTER OF BUSINESS ADMINISTRATION TWO YEARS P.G PROGRAM

(Applicable for the batches admitted from A.Y 2024-25)



ADITYA UNIVERSITY

Aditya Nagar, ADB Road, Surampalem - 533 437

VISION & MISSION OF THE UNIVERSITY

VISION

Aditya University aspires to be a globally recognised academic institution dedicated to quality education, cutting-edge research, and technological service to our country, and envisions itself as a beacon of holistic advancement and long-term impact, remaining dynamic in the ever-changing worlds of society, ecology, and economics

MISSION

- Aditya University pushes boundaries to design high-quality curricula and to provide students with a vibrant and relevant education that prepares them for a changing world. Our industry insights and creative teaching methods attempt to equip our students to be lifelong learners.
- Aditya University's learning environment encourages intellectual curiosity, critical thinking, and cooperation, with the goal of providing students with an immersive education that fosters creativity and innovation. Our cutting-edge facilities, interactive classrooms, and supportive faculty aim to motivate students to realise their full potential and contribute to society.
- Aditya University promotes cross-disciplinary inquiry and discovery and leads cutting-edge research and innovation. Through strategic partnerships, research grants, and a dedicated faculty, we aim to advance science, technology, and social sciences and empower students and faculty to conduct transformative research that solves real-world problems and elevates our institution globally.
- Aditya University is committed to producing world-changing business leaders and entrepreneurs through its emphasis on entrepreneurship, mentoring, and business incubation programmes.

VISION & MISSION OF THE DEPARTMENT

VISION:

To cultivate future business leaders who are not only equipped with cutting-edge knowledge and skills but are also driven by innovation, ethical leadership, and a commitment to global sustainability. We envision our MBA graduates as transformative leaders who excel in diverse, dynamic environments, leveraging their holistic business acumen to drive organizational success, societal impact, and personal growth.

MISSION:

- To develop ethical and innovative leaders with the skills to transform businesses and create long-term value. We focus on building responsible leaders who drive growth and positive change.
- To prepare adaptable, globally-minded leaders who excel in diverse business environments. We aim to empower students to lead with innovation and make a lasting impact.

PROGRAM OUTCOMES (PO)

After successful completion of the program, the students will be able to:

- PO1: Application of Management Principles:** Demonstrate the ability to apply foundational and advanced management concepts to address real-world business challenges with practical and effective solutions.
- PO2: Analytical and Critical Reasoning:** Develop strong analytical and critical thinking skills to support data-driven decision-making in dynamic business environments.
- PO3: Value-Centered Leadership:** Cultivate leadership capabilities rooted in integrity, ethics, and a commitment to creating long-term value for organizations and society.
- PO4: Global and Ethical Awareness:** Exhibit a deep understanding of global business dynamics, including economic, legal, and ethical considerations, and communicate these effectively in diverse business contexts.
- PO5: Collaborative Leadership:** Demonstrate the ability to lead and contribute meaningfully in team settings, effectively driving organizational objectives through shared vision and cooperation.
- PO6: Innovation and Research Orientation:** Identify emerging business opportunities, generate research insights, and implement innovative ideas across varied functional and sectorial domains.
- PO7: Tech-Driven Business Adaptability:** Stay abreast of disruptive and emerging technologies, applying them strategically to modernize and enhance business processes and models.
- PO8: Community Engagement and Impact:** Foster meaningful engagement with underserved communities through socially responsible outreach, aiming to create inclusive and transformative business solutions.

PROGRAM SPECIFIC OUTCOMES (PSO)

After successful completion of the program, the students will be able to:

- PSO1: Strategic and Functional Integration:** Graduates will be able to integrate knowledge across core business functions (marketing, finance, HR, operations, analytics) to solve complex business challenges and design effective organizational strategies.
- PSO2: Innovation, Entrepreneurship, and Business Transformation:** Graduates will demonstrate the ability to identify market opportunities, develop innovative solutions, and lead entrepreneurial ventures or transformational initiatives within existing organizations.
- PSO3: Data-Driven Decision-Making and Digital Agility:** Graduates will proficiently apply analytical tools, digital technologies, and data-driven insights to enhance organizational decision-making and drive competitive advantage in a technology-enabled global environment

PROGRAM EDUCATIONAL OUTCOMES (PEO)

After successful completion of the program, the students will be able to:

- PEO1** Demonstrate a deep understanding of core business principles and apply them to solve complex problems across various industries, ensuring effective decision-making and leadership in their organizations.
- PEO2** Actively seek continuous professional development, lifelong learning opportunities, by promoting high ethical standards in business practices, corporate social responsibility and sustainability, contributing to the welfare of communities and the environment.



Department of Management Studies
Master of Business Administration (MBA)
Program Curriculum-2024

Credit Division:

S. No	Category of Courses	Credits
1	Program Core Courses (PCC)	48
2	Program Elective Courses (PEC)	24
3	Summer Internship (SI)	2
4	Major Project (PROJ)	4
5	Article Publication (AP)	2
6	Mandatory courses (MC)	0
Total Credits		80

Program Core Courses (PCC)									
Course Code	Course Title	L	T	P	C	CIE	SEE	Total	Pre-requisite
244MS001	Management and Organization Behavior	3	0	0	3	50	50	100	
244MS002	Accounting for Managers	3	0	0	3	50	50	100	-
244MS003	Managerial Economics	3	0	0	3	50	50	100	-
244MS004	Business Statistics and Analysis for Decision-making	2	1	0	3	50	50	100	-
244MS005	Legal and Business Environment	3	0	0	3	50	50	100	-
244MS006	Fundamental Cognitive skills for Managers	0	0	1	1	100	-	100	-
244MS007	IT Skills	0	0	1	1	100	-	100	-
244MS008	Advanced Cognitive Skills for Managers	0	0	1	1	100	-	100	FCEM
244MS009	Financial Management	2	1	0	3	50	50	100	AM
244MS010	Marketing Management	3	0	0	3	50	50	100	-
244MS011	Human Resource Management	3	0	0	3	50	50	100	MOB
244MS012	Operations Management	3	0	0	3	50	50	100	BSAD
244MS013	Introduction to Business Analytics	2	0	1	3	50	50	100	ITS
244MS014	Business Research Methodology	2	1	0	3	50	50	100	-
244MS015	Entrepreneurship and New Age Business Models	2	0	0	2	50	50	100	-
244MS016	Business Ethics and Corporate Governance	2	0	0	2	50	50	100	LBE
244MS017	Strategic Management	3	0	0	3	50	50	100	-
244MS018	Managing Information Systems	2	0	0	2	50	50	100	-
244MS019	Business Taxation	2	1	0	3	50	50	100	-
	Total				48				

Program Elective Courses (PEC)

Finance (FIN)									
Course Code	Course Title	L	T	P	C	CIE	SEE	Total	Pre- requisite
244MS023	Investment Analysis and Port Folio Management	3	0	0	3	50	50	100	FM
244MS024	Banking and Financial Institutions	3	0	0	3	50	50	100	
244MS025	Financial Modelling	2	0	1	3	50	50	100	
244MS026	Mergers, Acquisitions and Corporate Restructuring	3	0	0	3	50	50	100	
244MS027	Financial Risk Management and Financial Derivatives	3	0	0	3	50	50	100	
244MS028	International Finance	3	0	0	3	50	50	100	
244MS029	Behavioral Finance	3	0	0	3	50	50	100	
244MS030	Financial Analytics	2	0	1	3	50	50	100	

Marketing (MKTG)									
Course Code	Course Title	L	T	P	C	CIE	SEE	Total	Pre- requisite
244MS031	Sales and Retail Management	3	0	0	3	50	50	100	MM
244MS032	Consumer Behavior & Customer Relationship Management	3	0	0	3	50	50	100	
244MS033	Marketing Analytics	2	0	1	3	50	50	100	
244MS034	Strategic Marketing Management	3	0	0	3	50	50	100	
244MS035	Digital & Social Media Marketing	3	0	0	3	50	50	100	
244MS036	Service Marketing	3	0	0	3	50	50	100	
244MS037	Marketing Research	3	0	0	3	50	50	100	
244MS038	Brand Management	3	0	0	3	50	50	100	

Human Resource Management (HR)									
Course Code	Course Title	L	T	P	C	CIE	SEE	Total	Pre-requisite
244MS039	Performance Management	3	0	0	3	50	50	100	HRM
244MS040	International Human Resource Management	3	0	0	3	50	50	100	
244MS041	HR Analytics	2	0	1	3	50	50	100	
244MS042	Organization Change and Development	3	0	0	3	50	50	100	
244MS043	Contemporary Practices in HR	3	0	0	3	50	50	100	
244MS044	Industrial Relations	3	0	0	3	50	50	100	
244MS045	Labor Welfare and Legislation	3	0	0	3	50	50	100	
244MS046	Compensation and Reward Management	3	0	0	3	50	50	100	

Business Analytics (BA)									
Course Code	Course Title	L	T	P	C	CIE	SEE	Total	Pre-requisite
244MS047	Data Analysis with R	2	0	1	3	50	50	100	IBA
244MS048	Marketing Analytics	2	0	1	3	50	50	100	
244MS049	Financial Analytics	2	0	1	3	50	50	100	
244MS050	HR Analytics	2	0	1	3	50	50	100	
244MS051	Predictive Analytics	2	0	1	3	50	50	100	
244MS052	Big Data Analytics	2	0	1	3	50	50	100	
244MS053	Web Analytics	2	0	1	3	50	50	100	
244MS054	Data Mining & Machine Learning	2	0	1	3	50	50	100	

Logistics and Supply Chain (LSC)									
Course Code	Course Title	L	T	P	C	CIE	SEE	Total	Pre-requisite
244MS055	Logistics Management	3	0	0	3	50	50	100	MM
244MS056	Store Keeping and Warehousing Management	3	0	0	3	50	50	100	
244MS057	Transportation and Infrastructure Management for SCM	3	0	0	3	50	50	100	
244MS058	Purchasing and Material Management	3	0	0	3	50	50	100	
244MS059	Reverse Logistics	3	0	0	3	50	50	100	
244MS060	Supply Chain Risk Management	3	0	0	3	50	50	100	
244MS061	Enterprise Resource Planning	3	0	0	3	50	50	100	
244MS062	International Logistics Management	3	0	0	3	50	50	100	

Information Systems Management (ISM)									
Course Code	Course Title	L	T	P	C	CIE	SEE	Total	Pre-requisite
244MS063	Data Mining for Business Decisions	2	0	1	3	50	50	100	ITS
244MS064	Managing Software Projects	2	0	1	3	50	50	100	
244MS065	Web Designing	2	0	1	3	50	50	100	
244MS066	Business Analytics	2	0	1	3	50	50	100	
244MS067	Managing Digital Innovation and Transformation	2	0	1	3	50	50	100	
244MS068	Big Data Analytics	2	0	1	3	50	50	100	
244MS069	Cyber Laws & Security	2	0	1	3	50	50	100	
244MS070	Information Systems Audit	2	0	1	3	50	50	100	

Digital Marketing (DM)									
Course Code	Course Title	L	T	P	C	CIE	SEE	Total	Pre-requisite
244MS071	Digital Startup and New Venture Management	3	0	0	3	50	50	100	MM
244MS072	Consumer Analytics	2	0	1	3	50	50	100	
244MS073	E- Mail Marketing	3	0	0	3	50	50	100	
244MS074	Mobile Marketing	3	0	0	3	50	50	100	
244MS075	Search Engine Optimization	3	0	0	3	50	50	100	
244MS076	Social Media Marketing	3	0	0	3	50	50	100	
244MS077	Content Marketing	3	0	0	3	50	50	100	
244MS078	Affiliate Marketing and Google Adsense	3	0	0	3	50	50	100	

Summer Internship (SI)									
Course Code	Course Title	L	T	P	C	CIE	SEE	Total	Pre-requisite
244MS020	Summer Internship	-	-	2	2	100	-	100	-
	Total				2				

Major Project (PROJ)									
Course Code	Course Title	L	T	P	C	CIE	SEE	Total	Pre-requisite
244MS021	Major project	-	-	4	4	50	50	100	-
	Total				4				

Article Publication (AP)									
Course Code	Course Title	L	T	P	C	CIE	SEE	Total	Pre-requisite
244MS022	Article Publication	-	-	2	2	100	-	100	-
	Total				2				

Mandatory Courses (MC)									
Course Code	Course Title	L	T	P	C	CIE	SEE	Total	Pre-requisite
244AC001	Sustainable Development for Business	0	0	0	0	100	-	100	-
244AC002	Corporate Readiness-I	0	0	0	0	100	-	100	-
244AC003	Corporate Readiness-II	0	0	0	0	100	-	100	CR-I
244AC004	Corporate Readiness-III	0	0	0	0	100	-	100	CR-II
244AC005	Aptitude Training	0	0	0	0	100	-	100	-
244AC006	AI in Business	0	0	0	0	100	-	100	-
244AC007	Design Thinking and Innovation	0	0	0	0	100	-	100	-
244AC008	Business Management Tools	0	0	0	0	100	-	100	ITS
244AC009	Intellectual Property Rights	0	0	0	0	100	-	100	-
244AC010	Project Management	0	0	0	0	100	-	100	-
244AC011	Employability Skills-I	0	0	0	0	100	-	100	-
244AC012	Employability Skills-II	0	0	0	0	100	-	100	ES-I
244AC013	Employability Skills-III	0	0	0	0	100	-	100	ES-II
	Total				0				

Students must opt for two of the Mandatory Courses per semester compulsorily.

2024 MBA CURRICULUM PREREQUISITE FLOW CHART

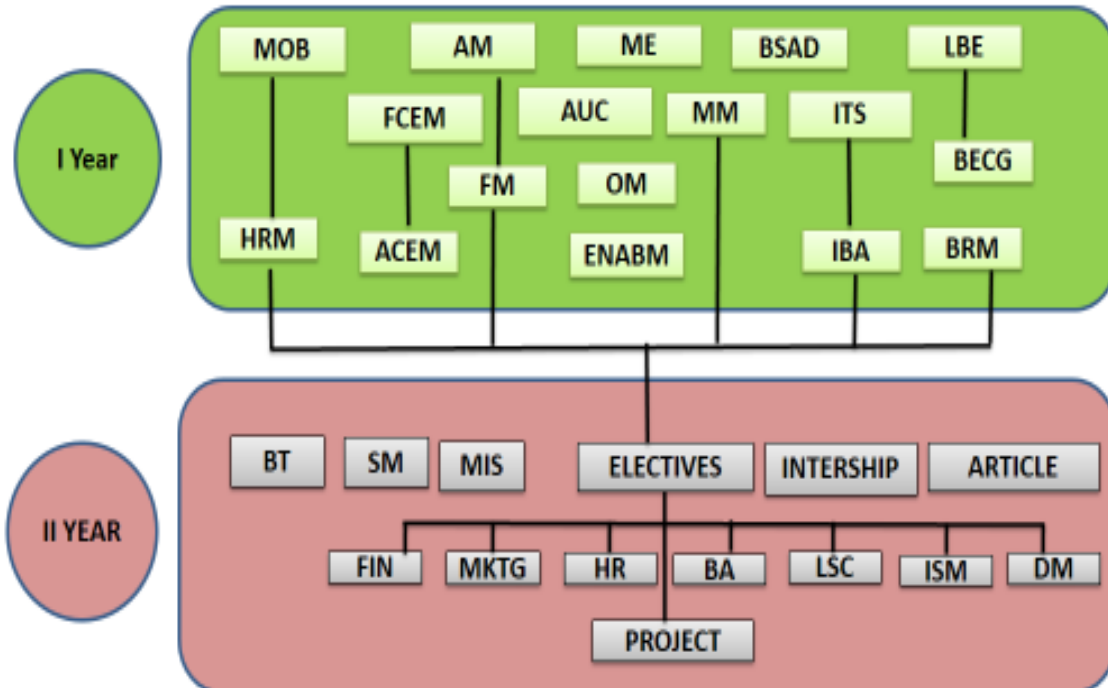

I Year Courses	
MOB	Management and Organization Behavior
AM	Accounting for Managers
ME	Managerial Economics
BSAD	Business Statistics and Analysis for Decision – making
LBE	Legal and Business Environment
FCEM	Fundamental Cognitive Skills for Managers
ITS	Information Technology Skills
HRM	Human Resource Management
FM	Financial Management
MM	Marketing Management
BRM	Business Research Methodology
ENABM	Entrepreneurship and New Age Business Models
OM	Operations Management
IBA	Introduction to Business Analytics
BECG	Business Ethics and Corporate Governance
ACEM	Advanced Cognitive Skills for Managers
MC	Mandatory Courses
II Year Courses	
SM	Strategic Management
MIS	Managing Information Systems
BT	Business Taxation
ELECTIVES	
FIN	Finance
MKTG	Marketing
HR	Human Resource Management
BA	Business Analytics
LSC	Logistics and supply chain
ISM	Information Systems
DM	Digital Marketing
SI	Summer Internship
PROJ	Major project
AP	Article publication
MC	Mandatory Courses

Suggestive Semester Wise Curriculum

SEMESTER-I							
Course Code	Course Title	Course Category	Credits				Total Hours
			L	T	P	Total	
244MS001	Management and Organization Behavior	PCC	3	0	0	3	3
244MS002	Accounting for Managers	PCC	2	1	0	3	3
244MS003	Managerial Economics	PCC	3	0	0	3	3
244MS004	Business Statistics and Analysis for Decision Making	PCC	2	1	0	3	3
244MS005	Legal and Business Environment	PCC	3	0	0	3	3
244MS014	Business Research Methodology	PCC	2	1	0	3	3
244MS007	IT Skills	PCC	0	0	1	1	2
244MS006	Fundamental Cognitive Skills for Managers	PCC	0	0	1	1	2
244AC011	Employability Skills-I	MC	0	0	0	0	3
---	Mandatory Course	MC	0	0	0	0	2
Total						20	27

SEMESTER-II							
Course Code	Course Title	Course Category	Credits				Total Hours
			L	T	P	Total	
244MS009	Financial Management	PCC	2	1	0	3	3
244MS010	Marketing Management	PCC	3	0	0	3	3
244MS011	Human Resource Management	PCC	3	0	0	3	3
244MS012	Operations Management	PCC	3	0	0	3	3
244MS013	Introduction to Business Analytics	PCC	2	0	1	3	4
244MS015	Entrepreneurship and New Age Business Models	PCC	2	0	0	2	2
244MS016	Business ethics and corporate governance	PCC	2	0	0	2	2
244MS008	Advanced Cognitive Skills for Managers	PCC	0	0	1	1	2
244AC012	Employability Skills-II	MC	0	0	0	0	3
---	Mandatory Course	MC	0	0	0	0	2
Total						20	27

SEMESTER-III							
Course Code	Course Title	Course Category	Credits				Total Hours
			L	T	P	Total	
244MS017	Strategic Management	PCC	3	0	0	3	3
244MS019	Business Taxation	PCC	2	1	0	3	3
244MS018	Managing Information Systems	PCC	2	0	0	2	2
----	Program Elective Course-I	PEC	3	0	0	3	3
----	Program Elective Course –II	PEC	3	0	0	3	3
----	Program Elective Course –III	PEC	3	0	0	3	3
----	Program Elective Course –IV	PEC	3	0	0	3	3
244MS020	Summer Internship	SI	-	-	2	2	-
244AC013	Employability Skills-III	MC	0	0	0	0	3
---	Mandatory Course	MC	0	0	0	0	2
Total						22	25

SEMESTER-IV							
Course Code	Course Title	Course Category	Credits				Total Hours
			L	T	P	Total	
----	Program Elective Course-V	PEC	3	0	0	3	3
----	Program Elective Course –VI	PEC	3	0	0	3	3
----	Program Elective Course –VII	PEC	3	0	0	3	3
----	Program Elective Course –VIII	PEC	3	0	0	3	3
244MS022	Article publication	AP	-	-	2	2	-
244MS021	Major Project	PROJ	-	-	4	4	-
----	Mandatory Course	MC	0	0	0	0	2
---	Mandatory Course	MC	0	0	0	0	2
Total						18	16

MANAGEMENT AND ORGANIZATION BEHAVIOR

Course Code: 244MS001	L	T	P	C
	3	0	0	3

Course Outcomes:

At the end of the Course, Student will be able to:

- CO1:** Explain the fundamental concepts and significance of management in organizations.
- CO2:** Analyze the planning process, its significance, and various planning types.
- CO3:** Examine the relationship between management and organizational behavior.
- CO4:** Explore various motivation theories and their application in organizational settings.
- CO5:** Assess the significance of organizational culture and its impact on behavior.

Mapping of Course Outcomes with Program Outcomes:

CO/PO	PO1	PO2	PO3	PO4	PO5	PO6	PO7	PO8
CO1	3	2	1	-	-	-	-	-
CO2	3	3	-	-	-	1	-	-
CO3	2	2	2	1	2	-	-	-
CO4	2	2	3	1	2	-	-	-
CO5	1	2	2	3	2	-	-	1

Mapping of Course Outcomes with Program Specific Outcomes:

CO/PSO	PSO1	PSO2	PSO3
CO1	3	1	-
CO2	3	2	1
CO3	3	2	1
CO4	2	3	1
CO5	3	2	1

UNIT – I

Management Concept: Definition, Nature, Functions and Importance of Management Evolution of Management thoughts, Approaches to Management practice, Levels of Management, Managerial roles, Functional areas of Management, Challenges of managing 21st century corporations/organization.

UNIT – II

Management Functions: Planning -process, significance, types, Organizing -concept, principles, Organization Structure and Design, Authority and Responsibility Relationships, power, delegation. Decentralization; Staffing- process and its importance in organizational success. Directing- components and techniques, Coordinating- need methods, Control - nature, process, and techniques.

UNIT – III

Foundations of Organizational Behavior: Management and Organizational Behavior, Individual Behavior characteristics, Personality, Emotional Intelligence, Perception, Attitude and Learning; Interpersonal Behavior, Communication and Transactional Analysis and Johari Window; OB Models; Foundations of Group behavior, formation of groups, Groups versus Teams, Group dynamics.

UNIT – IV

Motivation and Leadership: Work motivation, need theories, Theory X – Theory Y, Two Factor Theory, Ouchi's theory Z, Alderfer's ERG theory, McClelland's theory, Vroom's expectancy theory, Adams equity theory, contemporary issues in the practice of motivation; Leadership concept, styles, theories - contemporary issues in leadership development, power and politics.

UNIT – V

Management of Organizational Behavior: Organizational culture, managing conflict, work stress and its management, work-life balance; Managing change- nature, forces, resistance and resolution

Text Books:

- 1 Pierce & Gardner., Management and Organizational Behavior. Thomson, ISBN 0-324-04958-7.
- 2 Luthans, Fred, Organizational Behavior, ISBN 10:0070391610. McGraw-Hill, Indian Edition.

Reference Books:

- 1 Warren, Bennis, Leaders on Leadership-Interviews with top executives, ISBN 9780875843070. HBR Press.
- 2 George, C.S, The History of Management Thought, ISBN -13 978-0133901870. Englewood Cliffs, NJ: Prentice-Hall.

Web Links:

- 1 <https://archive.nptel.ac.in/courses/110/107/110107150/>
- 2 <https://archive.nptel.ac.in/courses/110/106/110106145/>

Relevant cases have to be discussed in each unit and in examination case study is compulsory from any unit.

ACCOUNTING FOR MANAGERS

Course Code: 244MS002	L	T	P	C
	3	0	0	3

Course Outcomes:

At the end of the Course, Student will be able to:

- CO1:** Explain the scope and nature of accounting, along with key concepts, principles, and standards.
- CO2:** Apply methods of fixed assets and depreciation accounting.
- CO3:** Analyze labor costing and overhead cost allocations, including over and under absorption.
- CO4:** Assess performance using standard costing, variance analysis, balanced scorecard, and responsibility accounting.
- CO5:** Analyze marginal costing and cost-volume-profit analysis for decision making and profit planning.

Mapping of Course Outcomes with Program Outcomes:

CO/PO	PO1	PO2	PO3	PO4	PO5	PO6	PO7	PO8
CO1	3	2	-	-	-	-	-	-
CO2	2	3	-	-	-	-	1	-
CO3	2	3	-	-	-	-	-	-
CO4	2	3	1	-	2	2	-	-
CO5	2	3	-	1	-	2	-	-

Mapping of Course Outcomes with Program Specific Outcomes:

CO/PSO	PSO1	PSO2	PSO3
CO1	3	1	-
CO2	3	2	2
CO3	3	2	2
CO4	3	3	2
CO5	3	2	3

UNIT – I

Financial Accounting: Scope and Nature of Accounting, Accounting concepts, Principles & Standards, Accounting Cycle, Journalizing, Subsidiary Books; Ledger Posting, Preparation of Trial Balance, Rectification of Errors. Capital and Revenue Expenditure & Income.

UNIT – II

Depreciation and Final Accounting: Fixed Assets and Depreciation Accounting. Preparation of Final Accounts, Manufacturing Account; Trading Account, Profit and Loss Account; Balance Sheet (with adjustments)

UNIT – III

Cost Accounting: Objectives, Classification of Cost, Preparation of Cost Sheet, Material Cost Accounting, Perpetual Inventory Control, Inventory Valuation, EOQ, ABC Analysis, Setting of Reorder Level, Maximum Level, Minimum Level, Labor Costing, Overhead Cost Allocations, Over and Under Absorption.

UNIT – IV

Performance Evaluation Techniques: Introduction to Budgeting and Budgetary Control; Performance Budgeting; Classification of Budget; Fixed and Flexible Budgets, Zero Based Budgeting, Standard Costing and Variance Analysis; Balanced Scorecard; Responsibility Accounting

UNIT – V

Decision Making Techniques: Financial Statement Analysis, Ratio Analysis, Common Size Statements, Du Pont Analysis, Marginal Costing, Application of Marginal Costing in Decision Making, Cost Volume Profit Analysis; Profit Planning, Management Accounting for Decision Making and Control; EVA; Introduction to Activity Based Costing, Target Costing, Life Cycle Costing; Uniform Costing

Text Books:

- 1 Arora, M. N. Cost Accounting Principles & Practice, ISBN-10: 9354530265, Vikas Publishing House.
- 2 Jawahar, L. Advanced Management Accounting, ISBN-13 978-9352533084 S. Chand & Company.

Reference Books:

- 1 Periasamy, P. Financial, Cost and Management Accounting, ISBN -10 9350510421, Himalaya Publishing.
- 2 Khan, M.Y. & Jain, P.K. Management Accounting, ISBN-10: 9354600395, McGraw Hill Education.

Web Links:

- 1 <https://archive.nptel.ac.in/courses/110/101/110101003/>
- 2 <https://nptel.ac.in/courses/110101004>

Relevant cases have to be discussed in each unit and in examination case study is compulsory from any unit.

MANAGERIAL ECONOMICS

Course Code: 244MS003	L	T	P	C
	3	0	0	3

Course Outcomes:

At the end of the Course, Student will be able to:

- CO1:** Explain the definition, nature, and scope of managerial economics and its relationship with other areas of economics.
- CO2:** Compare the types and significance of elasticity of demand and measure price elasticity of demand.
- CO3:** Apply the concepts of returns to scale and laws of returns.
- CO4:** Analyze cost-volume-profit analysis to understand its impact on business decisions.
- CO5:** Distinguish the features and types of different market structures.

Mapping of Course Outcomes with Program Outcomes:

CO/PO	PO1	PO2	PO3	PO4	PO5	PO6	PO7	PO8
CO1	3	2	1	2	-	-	-	-
CO2	2	3	-	2	-	-	-	-
CO3	3	3	-	-	-	1	-	-
CO4	2	3	-	-	-	2	-	-
CO5	2	3	1	2	-	-	-	-

Mapping of Course Outcomes with Program Specific Outcomes:

CO/PSO	PSO1	PSO2	PSO3
CO1	3	1	-
CO2	3	2	1
CO3	3	2	1
CO4	3	3	2
CO5	3	2	2

UNIT – I

Introduction to Managerial Economics: Definition, Nature and Scope, Relationship with other areas in Economics, The role of managerial economist. Concept of opportunity cost, Incremental concept, time Perspective, Discounting Principle, Risk & uncertainty.

UNIT – II

Demand Analysis: Elasticity of demand, types and significance of Elasticity of Demand - Measurement of price Elasticity of Demand – Need for Demand forecasting, forecasting techniques, Law of Supply, Elasticity of Supply.

UNIT – III

Production Analysis: Production function, Marginal Rate of Technical Substitution, Production functions with one/two variables, Cobb-Douglas Production Function, Returns to Scale and Laws of Returns.

UNIT – IV

Cost Theory and Estimation: Cost concepts, determinants of cost, cost – output relationship in the short run and long run – Modern development in cost theory – Saucer shaped short – run Average cost curves – Average total cost curve – Cost - Volume – Profit analysis.

UNIT – V

Market Structure and Pricing Practices: Features and types of different Markets – Price-Output determination in Perfect competition, Monopoly, Monopolistic competition and Oligopoly both in the long run and short run. Pricing methods in practice.

Market Failures: definition, types, causes, effects and corrective measures to market failures.

Macroeconomics: National income-definition, concepts, measurement of national income, Trade cycles, Monetary policy, Fiscal policy, inflation and balance of payment.

Text Books:

- 1 Principles And Worldwide Applications, 9E (Adaptation) by Dominick Salvatore and Siddhartha Rastogi, ISBN-13: 978-0199496563.
- 2 Vanita Agarwal: “Managerial Economics”, Pearson, New Delhi, ISBN 9332514062.

Reference Books:

- 1 D. L. Ahuja: “Managerial Economics”, S. Chand & Company ltd, New Delhi-55E, ISBN-10: 9355010672.
- 2 Paul, Koushil: “Managerial Economics”, Cengage Learning, New Delhi, ISBN-10: 8131516873.

Web Links:

- 1 <https://archive.nptel.ac.in/courses/110/101/110101149/>
- 2 <https://archive.nptel.ac.in/courses/110/105/110105075/>

Relevant cases have to be discussed in each unit and in examination case study is compulsory from any unit.

BUSINESS STATISTICS AND ANALYSIS FOR DECISION MAKING

	L	T	P	C
Course Code: 244MS004	2	1	0	3

Course Outcomes:

At the end of the Course, Student will be able to:

CO1: Explain the types of data and types of variables

CO2: Apply various concepts of descriptive statistics

CO3: Analyze the theories of probability

CO4: Solve the problems related to Linear programming.

CO5: Evaluate various transportation models and game theory.

Mapping of Course Outcomes with Program Outcomes:

CO/PO	PO1	PO2	PO3	PO4	PO5	PO6	PO7	PO8
CO1	3	2	-	-	-	2	-	-
CO2	3	3	-	-	-	2	-	-
CO3	3	3	-	-	-	2	-	-
CO4	3	3	-	-	-	3	-	-
CO5	3	3	1	-	-	3	-	-

Mapping of Course Outcomes with Program Specific Outcomes:

CO/PSO	PSO1	PSO2	PSO3
CO1	-	3	1
CO2	-	3	2
CO3	-	3	2
CO4	-	3	2
CO5	-	3	3

UNIT – I

Introduction to Business Statistics: Introduction to Statistics, Statistics in Business, Types of data – Nominal, Ordinal, Interval, Ratio. Types of variables – Dependent, independent, moderating, intervening, extraneous. Discrete / continuous. Charts and Graphs.

UNIT – II

Descriptive Statistics: Measure of central tendency – mean, median, quartile, mode (for Group and ungrouped data) Measure of variability – Range, interquartile range, standard deviation, variance, coefficient of variation, (for Group and ungrouped data) Measures of shape – kurtosis, skewness, boxplot.

UNIT – III

Introduction to Probability: Theories of probability – Classical, Relative frequency and subjective. Laws of probability – addition, multiplication. Inverse Probability. Revision of probability: BAYES' RULE, Discrete distribution – Binomial, Poisson, Continuous distribution – Uniform, normal.

UNIT – IV

Introduction to Linear Programming problems (LP) – LP Formulations – Graphical Solution – Simplex Method

UNIT – V

Classification of Models- Introduction –Transportation Models NWCR, LCM, VAM –MODI Method- Assignment Problem- Game theory: Saddle Point Determination, Dominance Property, Two Person Zero–sum Game

Text Books:

- 1 T N Srivastava, Shailaja Rego, Statistics for Management Paperback, TMH Publications, ISBN-13: 978-8184959963.
- 2 Ken Black, Business Statistics for Contemporary Decision making, Wiley Publications, ISBN-10: 1119905443.

Reference Books:

- 1 Richard I. Levin and David S. Rubin, Statistics for Management, Pearson Publications, ISBN-10: 8184957491.
- 2 Sanjiv Jaggia, Alison Kelly, Business Statistics, McGraw Hill Publications, ISBN-13; 978-0073373669.

Web Links:

- 1 <https://archive.nptel.ac.in/courses/110/107/110107114/>
- 2 <https://archive.nptel.ac.in/noc/courses/noc21/SEM1/noc21-mg07/>

Relevant cases have to be discussed in each unit and in examination case study is compulsory from any unit.

LEGAL AND BUSINESS ENVIRONMENT

Course Code: 244MS005	L	T	P	C
	3	0	0	3

Course Outcomes:

At the end of the Course, Student will be able to:

- CO1:** Explain the steps and procedures for the incorporation of a company and the appointment of directors.
- CO2:** Appraise the legality of object, unlawful and illegal agreements, contingent contracts, and the performance and discharge of contracts.
- CO3:** Analyze the offences by companies, amendments to the act, and RBI guidelines on digital transactions.
- CO4:** Evaluate the industrial policy, five-year planning and foreign direct investment (FDI).
- CO5:** Analyze the impact and effectiveness of these laws and regulations on business practices.

Mapping of Course Outcomes with Program Outcomes:

CO/PO	PO1	PO2	PO3	PO4	PO5	PO6	PO7	PO8
CO1	-	-	-	2	-	-	-	-
CO2	-	-	-	2	-	-	-	-
CO3	-	-	-	2	-	-	-	-
CO4	-	-	-	2	-	-	-	-
CO5	-	-	-	2	-	-	-	-

Mapping of Course Outcomes with Program Specific Outcomes:

CO/PSO	PSO1	PSO2	PSO3
CO1	2	-	-
CO2	2	-	-
CO3	2	-	-
CO4	2	-	-
CO5	2	-	-

UNIT – I

Companies Act, 2013, Steps and Procedure for Incorporation of a Company, Appointment of Directors, Powers, Duties, & Liabilities of Directors, Role of Audit and Auditors, Change of Auditors, Related Party Transactions, Company Meetings, Resolutions, Winding-up of a Company.

UNIT – II

Law of Contract: Nature and Types of Contract and Essential Elements of Valid Contract, Offer and Acceptance, Consideration, Capacity to Contract and Free Consent, Legality of Object. Unlawful and illegal Agreements, Contingent Contracts, Performance and Discharge of Contracts, Remedies for Breach of Contract. **Contracts-II:** Indemnity and Guarantee, Contract of Agency, Sale of Goods Act-1930: General Principles, Conditions & Warranties, Performance of Contract of Sale, Auction Sale and E-Auctions.

UNIT – III

Negotiable Instruments Act - 1881: Negotiable Instruments, Promissory Note, Bills of Exchange, & Cheque, Parties to Negotiable Instruments, Types of Endorsements, Holder, Holder in Due-course, Dishonor and Discharge of Negotiable Instruments, Offences by the Companies, Amendments, RBI Guidelines on Digital Transactions.

UNIT – IV

Business Environment: Industrial Policy, Five Year Planning, Foreign Direct Investment (FDI), Fiscal Policy, Latest Union Budget, Reforms Undertaken by the Government, Monetary Policy, Banking Sector Reforms, NITI Aayog, Responsibilities and Functions.

UNIT – V

Business Regulations and Environment Laws: a) Consumer Protection Act 2019, Information Technology Act 2000, Cyber Security Competition Act 2002, Intellectual Property Rights. b) Environmental Law: Water, Air Pollution, Green Tribunal in Protecting Environment, Sustainability Reporting Practices.

Text Books:

- 1 Rajdeep Banerjee, Joyeeta Banerjee, Legal Aspects of Business, Sage Publications, 1e, 2022, ISBN-10: 9354793177.
- 2 Ravinder Kumar, Legal Aspects of Business, Cengage Learning, 5e, 2021, ISBN-13: 9978-8131531594.

Reference Books:

- 1 Francis Cherunilam, Business Environment Text & Cases, Himalaya Publications, 13e, 2022, ISBN-13: 978-9352994427.
- 2 Akhileshwar Pathak, Legal Aspects of Business, TMH, 7e, 2019, ISBN-13: 9789-9355322081.

Web Links:

- 1 <https://archive.nptel.ac.in/courses/110/107/110107145/>
- 2 https://onlinecourses.swayam2.ac.in/imb22_mg02/preview

Relevant cases have to be discussed in each unit and in examination case study is compulsory from any unit.

FUNDAMENTAL COGNITIVE SKILLS FOR MANAGERS

Course Code: 244MS006	L T P C
	0 0 1 1

Course Outcomes:

At the end of the course, student will be able to:

- CO1:** Recognize the different aspects of the English language proficiency with emphasis on LSRW skills.
- CO2:** Apply communication skills through various language learning activities
- CO3:** Analyze the English speech sounds, stress, intonation and syllable division for better listening and speaking comprehension.
- CO4:** Enable them to learn and apply fundamentals of English grammar concepts for improved language
- CO5:** Make use of various types of vocabulary in different academic and professional careers

Mapping of Course Outcomes with Program Outcomes:

CO/PO	PO1	PO2	PO3	PO4	PO5	PO6	PO7	PO8
CO1	-	-	2	2	-	-	-	-
CO2	-	-	2	2	-	-	-	-
CO3	-	-	2	2	-	-	-	-
CO4	-	-	2	2	-	-	-	-
CO5	-	-	2	2	-	-	-	-

Mapping of Course Outcomes with Program Specific Outcomes:

CO/PSO	PSO1	PSO2	PSO3
CO1	1	-	-
CO2	1	-	-
CO3	1	-	-
CO4	1	-	-
CO5	1	-	-

List of the Topics

UNIT – I

Outstanding people A/B/C/D

- | | |
|----------------------|--|
| Listening | Conversation about Jocelyn Bell- Burnell, Podcast: The 30-day challenge, Starting a new job, Conversation about technology |
| Speaking | Discussing inspiring people, Asking and answering questions about challenges, Explaining a process; Checking understanding, Discussing technology. |
| Reading | Articles : <i>Protector of the sea and The woman who reinvented children's TV, Interviews: 30-day challenge, Article: Tech free!</i> |
| Writing | Article Organizing an article |
| Grammar | Review of Tenses, Questions |
| Vocabulary | Character adjectives, trying and succeeding |
| Pronunciation | The letter e; Word stress, Rapid speech |

UNIT – II
Survival A/B/C/D

Listening	Conversation about a survival situation, Interview: The Tiger, Cooking for a friend, Talking about getting lost
Speaking	Telling a survival story, Giving advice; Asking questions, Giving compliments and responding, Discussing the natural environment
Reading	Article: Lost at sea, Leaflet: <i>How to survive...an animal attack</i> , Leaflet: <i>Be wise and survive</i>
Writing	Guidelines, organizing guidelines in a leaflet
Grammar	Narrative tenses, Future time clauses and conditionals
Vocabulary	Expressions with <i>get</i> , Animals and the environment
Pronunciation	Sound and Spelling: g, Intonation in question tags

UNIT – III
Talent A/B/C/D

Listening	Conversation: learning experiences, Radio Programme: The sports gene, Making wedding plans, Interviews about sport
Speaking	Talking about something you have put a lot of effort into, Discussing sport and ways to improve performance, planning a party, Talking about popular sports
Reading	Text about learning; <i>Learning to learn</i> , Article: <i>Born to be the best</i> ; Three articles about athletes, Article: <i>Fitness: Seattle snapshot</i>
Writing	Article describing data
Grammar	Multi-word verbs, Present perfect and present perfect continuous
Vocabulary	Ability and achievement, word connected with sport
Pronunciation	Word stress, sound and spelling consonant sounds

UNIT – IV
Life Lessons A/B/C/D

Listening	Interview: Psychology of money; Two monologues: Life-changing events, two monologues; training for a job, presenting photos, Three monologues; living in different places
Speaking	Talking about how your life has changes, discuss experiences of training and rules, Describing photos: Expressing careful disagreement, Discussing living in a different country
Reading	Two texts about life-changing events that helped people become rich, Article: <i>Training for the emergency frontline</i> , Advert for being an international student ‘buddy’
Writing	Job application, Giving a positive impression
Grammar	<i>Used to</i> and <i>would</i>
Vocabulary	Cause and result, Talking about difficulty
Pronunciation	Sound and spelling: <i>u</i>

UNIT – V**Chance A/B/C/D**

Listening	Monologue: What are your chances? Conversation: Talking about work, Money problems, News reports: environmental problems
Speaking	Discussing possible future events, Role Play: job interview, Explaining and responding to an idea for a café, Giving opinions on environmental problems
Reading	Quiz: <i>Are you an optimist or a pessimist?</i> ; Article: <i>Why we think we're going to have a long and happy life</i> , Quiz: <i>The unknown continent</i> ; Article: <i>Cooking in Antarctica</i> , Essay about protecting the environment
Writing	For and against essay, Arguing for and against an idea
Grammar	Future probability, Future perfect and future continuous
Vocabulary	Adjectives describing attitude, The natural world
Pronunciation	Sound and spelling: <i>the</i> , Intonation groups

Text Book:

1. Cambridge Empower – Second Edition B2 Level - Adrian Doff, Craig Thaine, Herbert Puchta, Jeff Stranks ISBN- 978-1-108-95808-0

Suggested Softwares:

1. Cambridge Empower
2. Soft X (K-Van Solutions)

Reference Books:

1. M Ashraf Rizvi: Effective Technical Communication, ISBN- 9789352606108
2. Raymond Murphy: English Grammar in Use, Cambridge University Press. Fifth Edition, ISBN- 978-1009088015
3. J. Sethi & P.V. Dhamija. A Course in Phonetics and Spoken English, (2nd Ed), Kindle, 2013, ISBN- 9788120314955

Web links:

1. <https://www.cambridgeone.org/login>
2. <https://www.britishcouncil.in/english/online>
3. www.englishmedialab.com

IT SKILLS

Course Code:244MS007	L	T	P	C
	0	0	1	1

Course Outcomes:

At the end of the Course, Student will be able to:

- CO1:** Explain the fundamentals of computers and their applications in business.
- CO2:** Organize professional documents using MS Word.
- CO3:** Analyze business data using MS Excel's functions.
- CO4:** Develop impactful business presentations in MS PowerPoint.
- CO5:** Apply AI tools across MS Office applications

Mapping of Course Outcomes with Program Outcomes:

CO/PO	PO1	PO2	PO3	PO4	PO5	PO6	PO7	PO8
CO1	-	2	-	-	-	-	-	-
CO2	-	2	-	-	-	-	-	-
CO3	-	2	-	-	-	-	-	-
CO4	-	2	-	-	-	-	-	-
CO5	-	2	-	-	-	-	-	-

Mapping of Course Outcomes with Program Specific Outcomes:

CO/PSO	PSO1	PSO2	PSO3
CO1	-	2	-
CO2	-	2	-
CO3	-	2	-
CO4	-	2	-
CO5	-	2	-

UNIT – I

Introduction to Computers:

Definition, Components, Types; generations of computer; Computer Memory, Software and Hardware, Operating Systems. Window features. Introduction to Internet-benefit and limitation, IP address, Browser, E-mail.

UNIT – II

MS Word: Interface and Navigation; Document Formatting, Text Formatting, Paragraph Formatting, Advanced Features, Tables, Charts, and Smart Art, Mail Merge; AI Tools for MS Word.

UNIT – III

MS PowerPoint: Interface and Navigation; Slide Design and Layout, Adding and Formatting Text, Using Themes and Templates, Multimedia in Presentations, Presentation Tools, Slide Master and Custom Layouts, Slide Show Setup and Presentation Delivery; AI Tools for MS PowerPoint.

UNIT – IV

MS Excel: Interface and Navigation, Creating, Saving, and, Opening Workbooks, Basic Spreadsheet Operations, Entering and Formatting Data, Basic Formulas and Functions, Sorting and Filtering Data, Data Visualization, Creating and Customizing Charts, Conditional Formatting; AI Tools for MS Excel.

UNIT – V

Advanced Excel: Lookup Functions: VLOOKUP, HLOOKUP, and XLOOKUP; Logical Functions: IF, AND, OR; Text Functions: CONCATENATE, LEFT, RIGHT; Date and Time Functions: DATE, TODAY, NETWORKDAYS. Data Analysis and Visualization: PivotTables- Creating and analyzing data with PivotTables; Charts and Graphs: Designing and customizing basic charts; Conditional Formatting: Applying rules to highlight key data points. Data Cleaning Techniques: Using Text to Columns and Remove Duplicates; Data Validation: Setting up rules to ensure data accuracy; Importing Data: Importing data from external sources like CSV and databases.

Text Books:

- 1 Information Technology for Managers, by George Reynolds and Judith S. Reynolds (2022). Pearson Education, ISBN-13: 978-1305389830.
- 2 Computer Fundamentals and Information Technology, by Alexis Khosla (2022). BPB Publications, ISBN-13:978-8182092457.

Reference Books:

- 1 Information Technology for Management, by C.S.V. Murthy (2022). Himalaya Publishing House, ISBN-13: 9350516772.
- 2 Information Technology: An Introduction, by K.C. Laudon and Jane P. Laudon (2021) Pearson Education India, ISBN-13: 978-9352865475.

Web Links:

- 1 https://onlinecourses.swayam2.ac.in/cec20_cs05/preview
- 2 https://onlinecourses.nptel.ac.in/noc22_mg35/preview

ADVANCED COGNITIVE SKILLS FOR MANAGERS

Course Code: 244MS008	L	T	P	C
	0	0	1	1

Course Outcomes:

At the end of the course, student will be able to:

- CO1:** Recognize the basics of communication and summarize formal and informal language expressions in all aspects.
- CO2:** Establish and maintain interpersonal relationships and transmit the message through different language activities.
- CO3:** Use language effectively to prepare and demonstrate proficiency in facing various types of interviews.
- CO4:** Demonstrate and exhibit professionalism in participating in various public speaking activities like debates, group discussions and presentation skills.
- CO5:** Identify the basic elements of writing and apply the fundamentals to compose e-mails catering to different professional needs.

Mapping of Course Outcomes with Program Outcomes:

CO/PO	PO1	PO2	PO3	PO4	PO5	PO6	PO7	PO8
CO1	-	-	2	2	-	-	-	-
CO2	-	-	2	2	-	-	-	-
CO3	-	-	2	2	-	-	-	-
CO4	-	-	2	2	-	-	-	-
CO5	-	-	2	2	-	-	-	-

Mapping of Course Outcomes with Program Specific Outcomes:

CO/PSO	PSO1	PSO2	PSO3
CO1	1	-	-
CO2	1	-	-
CO3	1	-	-
CO4	1	-	-
CO5	1	-	-

List of the Topics

UNIT – I

Around the globe A/B/C/D

- | | |
|----------------------|--|
| Listening | Two monologues about sightseeing tours, Interview: disappearing languages, Asking for a favour, conversation: a trip to the Grand Canyon |
| Speaking | Comparing different tourist destinations, Agreeing and disagreeing, Asking for a favour, Discussing local tourist destinations. |
| Reading | Website about four tourist destinations; Website: Where to go? |
| Writing | Travel blog, Using descriptive language |
| Grammar | Infinitives and –ing forms |
| Vocabulary | Travel and tourism, Describing changes |
| Pronunciation | Consonant clusters, Consonant sounds |

UNIT –II
City living A/B/C/D

Listening	Interview: ‘Smart’ cities: Two monologues talking about ‘smart’ cities, Two monologues: house renovations, Flat hunting, Interviews about a new shopping centre
Speaking	Discussing good and bad points about a city
Reading	Article: <i>Quick-slow down!</i> , Article: <i>Who puts the ‘real’ in reality TV?</i> Email: Complaining about an important issue.
Writing	Email of complaint, Using formal language
Grammar	<i>Too/enough; so/such, Causative have/get</i>
Vocabulary	Describing life in cities, Film and TV; Houses
Pronunciation	Sound and spelling: o, Stress in compound nouns

Unit – III
Dilemmas A/B/C/D

Listening	Radio programme: person finance, Three monologues about honesty, Going to the bank, Conversation about a TV programme
Speaking	Giving opinions on financial matters, Discussing moral dilemmas, Talking about hopes and worries Discussing programmes about crime
Reading	Article: <i>Is it time to give up on cash?</i> , Newspaper article: <i>The honesty experiment</i> , Review: <i>Crime with a smile</i>
Writing	Review, Organising a review
Grammar	First and second conditionals, Third conditional; <i>should have+past participle</i>
Vocabulary	Money and finance, Crime
Pronunciation	Stressed and unstressed words; Sound and spelling: <i>l</i> , Word groups

Unit –IV
Discoveries A/B/C/D

Listening	Conversation about inventions, Conversation about an email hoax, Finding the perfect flat, Four monologues about alternative medicine
Speaking	Talking about inventions, describing a hoax or a scam or a case of fraud, Giving and receiving surprises
Reading	Article: <i>Too good to be true?</i> , Article: <i>The rise and fall of Barry Minkow</i> , Essay: <i>The Value of alternative medicine</i>
Writing	Opinion essay, Presenting a series of arguments
Grammar	Relative clauses, Reported speech; Reporting verbs
Vocabulary	Health, Verbs describing thought and knowledge
Pronunciation	Sound and spelling: <i>ui</i> , Linking and intrusion

Unit – V
Possibilities A/B/C/D

Listening	Interview about Dan Cooper, Two monologues: pursuing a dream, Celebrating good news, conversation about goals
Speaking	Telling stories about coincidences, Describing and comparing brave or amazing people, Telling an important piece of news, Talking about performing
Reading	Story: The man who disappeared; Blog: <i>The Wreck of the Titan</i> , Article: <i>Dream to help</i> , Story: Rosa’s diary: <i>The ultimate goal</i>

Writing	Story, Making a story interesting
Grammar	Past modals of deduction, Wishes and regrets
Vocabulary	Adjectives with prefixes, Verbs of effort
Pronunciation	Word stress, Linking, Consonant clusters

Text Book:

1. Cambridge Empower – Second Edition B2 Level - Adrian Doff, Craig Thaine, Herbert Puchta, Jeff Stranks) ISBN- 978-1-108-95808-0

Suggested Software:

1. Cambridge Empower
2. Soft X (K-Van Solutions)

Reference Books:

1. Raman Meenakshi, Sangeeta-Sharma. Technical Communication. Oxford University Press.2018. ISBN- 9780199457496
2. Michael Swan- Practical English Usage, ISBN- 978-0194202466
3. Taylor Grant: English Conversation Practice, Tata McGraw-Hill Education India,2016. ISBN- 978-0070996038

Web links:

1. <https://www.cambridgeone.org/login>
2. <https://www.coursera.org/>
3. <https://www.skillshare.com/>
4. <https://www.mindtools.com/cawh8bu/communication-tools>

FINANCIAL MANAGEMENT

Course Code: 244MS009	L	T	P	C
	2	1	0	3

Course Outcomes:

At the end of the Course, Student will be able to:

- CO1:** Explain the concept of time value of money.
- CO2:** Apply the capital budgeting techniques and cost of capital.
- CO3:** Assess the significance of Capital structure vs. financial structure.
- CO4:** Analyze dividend policies of Indian companies, determinants of working capital, analysis of investment in inventory.
- CO5:** Evaluate the Concepts and Applications of Working Capital Management and Management of Current Assets.

Mapping of Course Outcomes with Program Outcomes:

CO/PO	PO1	PO2	PO3	PO4	PO5	PO6	PO7	PO8
CO1	1	2	-	-	-	-	-	-
CO2	1	2	-	-	-	-	-	-
CO3	1	2	-	-	-	-	-	-
CO4	1	2	-	-	-	-	-	-
CO5	1	2	-	-	-	-	-	-

Mapping of Course Outcomes with Program Specific Outcomes:

CO/PSO	PSO1	PSO2	PSO3
CO1	2	-	-
CO2	2	-	-
CO3	2	-	-
CO4	2	-	-
CO5	2	-	-

UNIT – I

The Finance Function: Nature and Scope, Evolution of Finance Function, Its New Role in the Contemporary Scenario, Goals of Finance Function, Profit Maximization and Wealth Maximization, the Agency Relationship and Costs; Risk-Return Trade off; Concept of Time Value of Money, Future Value and Present Value and the Basic Valuation Model.

UNIT – II

The Investment Decision: Investment Decision Process, Project Generation, Evaluation, Selection, Implementation. Developing Cash Flow, Data for New Projects, Capital Budgeting Techniques: Traditional and DCF Methods. The NPV vs. IRR Debate, Approaches for Reconciliation. Capital Budgeting Decision under Conditions of Risk and Uncertainty.

UNIT – III

Capital Structure and Cost of Capital: Capital Structure vs. Financial Structure, Capital Structure Theories: The Modigliani Miller Theory, NI, NOI Theory and Traditional Theory, Cost of Capital: Concept, Importance and Measurement of Cost of Capital, Weighted Average and Marginal Cost of Capital. Financial Leverage, Operating Leverage and Composite Leverage. EBIT-EPS Analysis, Indifference Point/Break-even Analysis of Financial Leverage,

UNIT – IV

Dividend Decisions: Dividends and Value of the Firm, Relevance of Dividends, the MM Hypothesis, Factors Determining Dividend Policy, Dividends and Valuation of the Firm, the Basic Models, Forms of Dividend. Declaration and Payment of Dividends. Bonus Shares, Rights Issue, Share splits, Major Forms of Dividends, Cash and Bonus Shares. Dividends and Valuation. Major Theories centered on the works of Gordon, Walter and Lintner.

UNIT – V

Working Capital Management: Working Capital Management: Components of Working Capital, Gross vs. Net Working capital, Determinants of Working Capital Needs, the Operating Cycle Approach. Financing of Working Capital through Bank Finance and Trade Credit, Management of Current Assets, Management of Inventory: Process, Inventory Control Systems, and Analysis of Investment in Inventory.

Text Books:

1. Prasanna Chandra, Financial Management, 10e, McGraw Hill, ISBN-13:978-9353166526.
2. M.Y Khan, P K Jain, Financial Management-Text and Problems, McGraw Hill, ISBN-13-978-9353162184.

Reference Books:

1. I M Pandey, Financial Management, Vikas Publications, 11e, ISBN-13: 812591658X.
2. James Cvan Horne, Sanjay Dhamija, Financial Management and Policy, Pearson Education, New Delhi, 12e, ISBN-9788131754467.

Web Links:

1. https://onlinecourses.nptel.ac.in/noc20_mg31/preview
2. <https://archive.nptel.ac.in/courses/110/107/110107144/>

Relevant cases have to be discussed in each unit and in examination case study is compulsory from any unit.

MARKETING MANAGEMENT

Course Code:244MS010	L	T	P	C
	3	0	0	3

Course Outcomes:

At the end of the Course, Student will be able to:

- CO1:** Explain marketing and the core marketing concepts
- CO2:** Select market segments based on effective segmentation criteria
- CO3:** Analyze products, the product life cycle, and propose strategies for new product development
- CO4:** Assess pricing strategies, the relevance of the value chain to marketing, and customer lifetime value
- CO5:** Evaluate integrated marketing channels, manage retailing and logistics, and the effectiveness of various promotional strategies

Mapping of Course Outcomes with Program Outcomes:

CO/PO	PO1	PO2	PO3	PO4	PO5	PO6	PO7	PO8
CO1	3	2	1	-	-	-	-	-
CO2	3	3	-	-	-	1	-	-
CO3	2	2	2	1	2	-	-	-
CO4	2	2	3	1	2	-	-	-
CO5	1	2	2	3	2	-	-	1

Mapping of Course Outcomes with Program Specific Outcomes:

CO/PSO	PSO1	PSO2	PSO3
CO1	3	1	-
CO2	3	2	1
CO3	3	2	1
CO4	2	3	1
CO5	3	2	1

UNIT – I

Understanding Marketing World: Defining Marketing for the New Realities - The Scope of Marketing - Core Marketing Concepts - Marketing Environment; Selling Vs Marketing; Company Orientation toward the Marketplace; Marketing Mix.

UNIT – II

Segmentation, Targeting and Positioning: Segmentation - Bases for Segmenting Consumer Markets - Geographic Segmentation - Demographic Segmentation - Psychographic Segmentation - Behavioral Segmentation - Market Targeting; Effective Segmentation Criteria - Evaluating and Selecting the Market Segments – Positioning.

UNIT – III

Product Concept and Brand Management: Setting Product Strategy - Product Classification, Product Levels, Product Line and Mix Concept, Product Life Cycle and New Product Development - Introducing New Market Offerings - Building Loyalty - Brand Communities - Win-Backs - Cultivating Customer Relationships - Customer Relationship Management.

UNIT – IV

Pricing, Value Chain and Customer Value: Developing Pricing Strategies and Programs – Understanding the Value Chain and its Relevance to Marketing – Managing Customer Value; The Value Delivery Process – The Value Chain – Building Customer Value, Satisfaction, and Loyalty – Measuring Customer Life Time Value and – Retaining Customers.

UNIT – V

Distribution and Promotion: Designing and Managing Integrated Marketing Channels – Managing Retailing, Wholesaling and Logistics. Designing and Managing Integrated Marketing Communications – Managing Mass Communications: Advertising, Sales Promotions, Events and Experiences and Public Relations.

Text Books:

- 1 Kotler, P., Keller, K. L., Chernev. A., Sheth. J.N., Shainesh. G., (2022), Marketing Management, 16th Edition, ISBN-978-9356062665
- 2 Hair, J. F., Lamb, C. W., McDaniel, C., MKTG, United States: Cengage Learning ISBN-9780324362084.

Reference Books:

- 1 Hartley, S. W., Kerin, R. A. (2021), Marketing, 15th Edition, United States: McGrawHill Education, ISBN-9781259573545.
- 2 Harris, L. C., He, H., Armstrong, G., Piercy, N., Kotler, P. T. (2019), Principles of Marketing, 8th Edition, United Kingdom: Pearson Education, ISBN-9781292092898.

Web Links:

- 1 <https://archive.nptel.ac.in/courses/110/104/110104068/>
- 2 https://onlinecourses.nptel.ac.in/noc22_mg57/preview

Relevant cases have to be discussed in each unit and in examination case study is compulsory from any unit

HUMAN RESOURCE MANAGEMENT

	L	T	P	C
Course Code:244MS011	3	0	0	3

Course Outcomes:

At the end of the Course, Student will be able to:

- CO1:** Explain the evolution, functions, and current trends in HRM
- CO2:** Analyze factors affecting HRP, job analysis techniques, and recruitment and selection methods
- CO3:** Assess training needs, training programs, and executive development techniques
- CO4:** Evaluate employee performance appraisal methods and wage administration principles and incentive plans
- CO5:** Analyze the concept of industrial relations, causes of disputes, and measures to enhance trade union effectiveness

Mapping of Course Outcomes with Program Outcomes:

CO/PO	PO1	PO2	PO3	PO4	PO5	PO6	PO7	PO8
CO1	2	-	1	-	1	-	-	-
CO2	2	-	1	-	1	-	-	-
CO3	2	-	1	-	1	-	-	-
CO4	2	-	1	-	1	-	-	-
CO5	2	-	1	-	1	-	-	-

Mapping of Course Outcomes with Program Specific Outcomes:

CO/PSO	PSO1	PSO2	PSO3
CO1	2	-	-
CO2	2	-	-
CO3	2	-	-
CO4	2	-	-
CO5	2	-	-

UNIT – I

Introduction to Human Resource Management: Introduction, Meaning and Definitions, Nature, Scope, Importance and Objectives of HRM, Evolution of HRM, Functions of HRM, Roles and responsibilities of HR Manager, current trends in HR.

UNIT – II

HR Planning, Recruitment and Selection: Meaning, Objectives, Importance and Process of HRP, Factors Affecting HRP, Job Analysis, Job description and job specification, Recruitment- Purpose, Process, Sources and Methods of Recruitment, Selection- Importance and processes of selection, Types and uses of Tests in selection, Interview- Types and Methods of Selection Interview. Importance and Process of employee Induction/Orientation.

UNIT – III

Training and Development: Meaning, Objectives, Importance of training, Assessment of training needs, Process of training. Methods of Training, Designing a Training Program, Executive Development, Methods and techniques of Executive Development, Promotion, Transfer, Demotion and Separation, Career Planning, Process, Career Development

UNIT – IV

Performance Appraisal: Meaning, Objectives, Need and Importance of Performance Appraisal, Process of performance appraisal, Different Methods of appraising employee performance.

Wage and Salary Administration: Objectives and Principles, Essentials of a sound wage structure, Methods of wage payments, Incentive Plans, Types of Incentive Plans, and Profit Sharing, Job evaluation, Fringe benefits and Employee Welfare.

UNIT – V

Industrial Relations: Concept, Meaning, Characteristics, Objectives and Approaches of Industrial Relations, Causes and measures for Industrial Relations, Factors influencing Industrial Relations, Role of Trade Unions, Nature, Problems of Trade Unions, Measures to Strengthen Trade Union Movement in India, Causes for Industrial Disputes, Settlement of Industrial Disputes.

Text Books:

- 1 Gary Dessler, Biju Varkkey, (2020), Human Resource Management, 15th edition, Pearson Education, ISBN- 9788131725382.
- 2 S.S. Khanka (2019), Human Resource Management, S. Chand & Company Ltd., New Delhi, ISBN-9788121923002.

Reference Books:

- 1 C.B. Mamoria & V.S.P. Rao, Personnel Management (Text and Cases), Himalaya Publishing Houses Pvt. Ltd., Mumbai, ISBN- 9789350514689.
- 2 Aswathappa K (2021), Human Resource Management: Text and Cases, Tata McGraw-Hill, ISBN-9780070682139.

Web Links:

- 1 <https://archive.nptel.ac.in/courses/110/105/110105069/>
- 2 https://onlinecourses.nptel.ac.in/noc21_mg21/preview

Relevant cases have to be discussed in each unit and in examination case is compulsory from any unit.

OPERATIONS MANAGEMENT

Course Code:244MS012

L	T	P	C
3	0	0	3

Course Outcomes:

At the end of the Course, Student will be able to:

- CO1:** Explain the Relationship of Operations management with other functional areas and different types of Production Systems.
- CO2:** Analyze the stages of the product design process, value analysis techniques, and facility location and layout decisions
- CO3:** Apply the methods of forecasting, operation planning strategies, and capacity planning techniques including MRP and scheduling
- CO4:** Analyze the factors affecting productivity, job design principles, and process flow charts and methods study
- CO5:** Apply the techniques of Statistical Quality Control and Total Quality Management.

Mapping of Course Outcomes with Program Outcomes:

CO/PO	PO1	PO2	PO3	PO4	PO5	PO6	PO7	PO8
CO1	1	2	-	-	-	-	-	-
CO2	1	2	-	-	-	-	-	-
CO3	1	2	-	-	-	-	-	-
CO4	1	2	-	-	-	-	-	-
CO5	1	2	-	-	-	-	-	-

Mapping of Course Outcomes with Program Specific Outcomes:

CO/PSO	PSO1	PSO2	PSO3
CO1	-	2	-
CO2	-	2	-
CO3	-	2	-
CO4	-	2	-
CO5	-	2	-

UNIT – I

Introduction to Operation Management: Nature & Scope of Operation/ Production Management, Relationship with other functional areas, Recent trend in Operation Management, Manufacturing & Theory of Constraint, Types of Production System, Just in Time (JIT) & lean system.

UNIT – II

Product Design & Process Selection: Stages in Product Design process, Value Analysis, Facility location & Layout: Types, Characteristics, Advantages and Disadvantages, Work measurement, Job design.

UNIT – III

Forecasting & Capacity Planning: Methods of Forecasting, Overview of Operation Planning, Aggregate Production Planning, Production strategies, Capacity Requirement Planning, MRP, Scheduling, Supply Chain Management, Purchase Management, Inventory Management.

UNIT – IV

Productivity: Factors, Affecting Productivity – Job Design – Process Flow Charts – Methods Study – Work Measurement – Engineering and Behavioral Approaches.

UNIT – V

Quality Management: Quality- Definition, Dimension, Cost of Quality, Quality Circles Continuous improvement (Kaizen), ISO (9000&14000 Series), Statistical Quality Control: Variable & Attribute, Process Control, Control Charts -Acceptance Sampling Operating Characteristic Curve (AQL, LTPD, Alpha & Beta risk), Total Quality Management (TQM).

Text Books:

- 1 Krajewski & Ritzman. Operation Management -Strategy and Analysis. Prentice Hall of India, ISBN-9780201331189.
- 2 Panner Selvem, Production and Operation Management, Prentice Hall of India, ISBN-978-8120345553.

Reference Books:

- 1 Charry, S.N. Production and Operation Management- Concepts, Methods Strategy, MCGraw-hill education (India) pvt limited, ISBN-9780070583559.
- 2 K Aswathappa& Sridhar Bhatt, Production & Operations Management, Himalaya, Mumbai, ISBN-13: 978-9350971888.

Web Links:

- 1 https://onlinecourses.nptel.ac.in/noc20_me30/preview
- 2 <https://archive.nptel.ac.in/courses/110/107/110107141/>

Relevant cases have to be discussed in each unit and in examination case study is Compulsory from any unit.

INTRODUCTION TO BUSINESS ANALYTICS

	L	T	P	C
Course Code: 244MS013	2	0	1	3

Course Outcomes:

At the end of the Course, Student will be able to:

- CO1:** Explain the historical overview and importance of business analytics in practice.
- CO2:** Organize various sources of data and data visualization.
- CO3:** Analyze data mining and multi-dimensional data analysis.
- CO4:** Apply the concepts of machine learning.
- CO5:** Apply the concepts of analytics in business areas such as retail, marketing, finance, health care and supply chain.

Mapping of Course Outcomes with Program Outcomes:

CO/PO	PO1	PO2	PO3	PO4	PO5	PO6	PO7	PO8
CO1	-	2	-	-	-	-	-	-
CO2	-	2	-	-	-	-	-	-
CO3	-	2	-	-	-	-	-	-
CO4	-	2	-	-	-	-	-	-
CO5	-	2	-	-	-	-	-	-

Mapping of Course Outcomes with Program Specific Outcomes:

CO/PSO	PSO1	PSO2	PSO3
CO1	-	2	-
CO2	-	2	-
CO3	-	2	-
CO4	-	2	-
CO5	-	2	-

UNIT – I

Introduction: What is business analytics? Historical Overview of data analysis, Data Scientist vs. Data Engineer vs. Business Analyst, Career in Business Analytics, what is data science, Why Data Science, Applications for data science, Data Scientists Roles and Responsibility

UNIT – II

Data: Data Collection, Data Management, Big Data Management, Organization/sources of data, Importance of data quality, Dealing with missing or incomplete data, Data Visualization, Data Classification Data Science Project Life Cycle: Business Requirement, Data Acquisition, Data Preparation, Hypothesis and Modeling, Evaluation and Interpretation, Deployment, Operations, Optimization.

UNIT – III

Introduction to Data Mining: The origins of Data Mining, Data Mining Tasks, OLAP and Multidimensional data analysis, Basic concept of Association Analysis and Cluster Analysis.

UNIT – IV

Introduction to Machine Learning: History and Evolution, AI Evolution, Statistics Vs Data Mining Vs, Data Analytics Vs, Data Science, Supervised Learning, Unsupervised Learning, Reinforcement Learning, Frameworks for building Machine Learning Systems.

UNIT – V

Application of Business Analytics: Retail Analytics, Marketing Analytics, Financial Analytics, Healthcare Analytics, Supply Chain Analytics.

Text Books:

- 1 Anil Maheswari, Big Data, Tata McGraw Hill, New Delhi, 2e, 2019, ISBN-9789353167967.
- 2 James Evans, Business Analytics, Pearson Education, 2e, ISBN-10: 9390394589.

Reference Books:

- 1 Camm, Cochran, Fry, Ohlmann, Anderson, Sweeney, Williams Essential of Business Analytics, Cengage Learning, ISBN-13: 978-1337406420.
- 2 Foster Provost and Tom Fawcett, Data Science for Business, O Relly media, ISBN- 9781449374280.

Web Links:

- 1 <https://nptel.ac.in/courses/110106050>
- 2 <https://archive.nptel.ac.in/courses/110/105/110105089/>

Relevant cases have to be discussed in each unit and in examination case study is Compulsory from any unit.

BUSINESS RESEARCH METHODOLOGY

	L	T	P	C
Course Code: 244MS014	2	1	0	3

Course Outcomes:

At the end of the Course, Student will be able to:

- CO1:** Explain the nature and importance of business research, types of research and ethical issues in business research
- CO2:** Apply the tools and techniques for collecting primary and secondary data, appropriate sampling methods, questionnaires and scales
- CO3:** Evaluate appropriate survey research designs, manage fieldwork effectively, and data editing, coding, and graphical presentation
- CO4:** Analyze formation of hypotheses and tests of hypothesis (parametric and non-parametric).
- CO5:** Apply multivariate techniques, dependencies and interdependencies among variables

Mapping of Course Outcomes with Program Outcomes:

CO/PO	PO1	PO2	PO3	PO4	PO5	PO6	PO7	PO8
CO1	1	2	-	-	-	-	-	-
CO2	1	2	-	-	-	-	-	-
CO3	1	2	-	-	-	-	-	-
CO4	1	2	-	-	-	-	-	-
CO5	1	2	-	-	-	-	-	-

Mapping of Course Outcomes with Program Specific Outcomes:

CO/PSO	PSO1	PSO2	PSO3
CO1	-	2	-
CO2	-	2	-
CO3	-	2	-
CO4	-	2	-
CO5	-	2	-

UNIT – I

Introduction: Nature and Importance of Research, The role of Business Research, Types of Research- Pure research vs. Applied research, Qualitative research vs. Quantitative research, Exploratory research, Descriptive research and Experimental research, ethical issues in business research- Defining Research Problem, Steps in Research process, Formulation of Hypothesis, Introduction to Null hypothesis vs. alternative hypothesis

UNIT – II

Data Collection: Discussion on primary data and secondary data, tools and techniques of collecting data. Methods of collecting data. Sampling design and procedures. Random vs. Non-random sampling techniques, determination of sample size and an appropriate sampling design. Designing of Questionnaire, Measurement and Scaling, Nominal Scale, Ordinal Scale, Interval Scale, Ratio Scale, Guttman Scale, Likert Scale, Schematic, Differential Scale.

UNIT – III

Survey Research and Data Classification: Selection of an appropriate survey research design, the nature of field work and Field work management. Media used to communicate with Respondents, Personal Interviews, Telephone interviews, Self-administered Questionnaires, Editing, Coding, Classification of Data, Tables and Graphic Presentation, Preparation and Presentation of Research Report.

UNIT – IV

Statistical Inference: Tests of Hypothesis, parametric vs. non-parametric tests, procedure for testing of hypothesis, tests of significance for small samples, application, t-test, Chi Square test.

UNIT – V

Multivariate Analysis: Nature of multivariate analysis, classifying multivariate techniques, analysis of dependence, analysis of interdependence. Bi-Variate analysis tests of differences, t test for comparing two means and z-test for comparing two proportions and ANOVA for complex experimental designs

Text Books:

- 1 Willam G.Zikmund, Adhikari: —Business Research Methods, Learning, New Delhi, ISBN-9788131520369.
- 2 C.R. Kothari: Research Methodology, methods and Techniques New Age International Publisher, ISBN-13:978-9389802559.

Reference Books:

- 1 Navdeep and Gupta: —Statistical Techniques & Research Methodology, Kalyani Publishers, ISBN-13:978-8127245559
- 2 A.N. Sadhu, Amarjit singh, Research methodology in social sciences, 7th Edition Himalaya Publications, ISBN-978-93-5202-295-3.

Web Links:

- 1 https://onlinecourses.swayam2.ac.in/cec20_mg14/preview
- 2 <https://archive.nptel.ac.in/courses/110/107/110107080/>

Relevant cases have to be discussed in each unit and in examination case is compulsory from any unit.

ENTREPRENEURSHIP AND NEW AGE BUSINESS MODELS

	L	T	P	C
Course Code: 244MS015	2	0	0	2

Course Outcomes:

At the end of the Course, Student will be able to:

- CO1:** Explain the individual entrepreneurial mind-set and Personality.
- CO2:** Develop strategic perspectives in entrepreneurship
- CO3:** Analyze the different types of business models.
- CO4:** Analyze the role of technology in business models and types of segment profiling.
- CO5:** Evaluating the strength and reasons for failure of a business model

Mapping of Course Outcomes with Program Outcomes:

CO/PO	PO1	PO2	PO3	PO4	PO5	PO6	PO7	PO8
CO1	-	2	-	-	-	-	-	-
CO2	-	2	-	-	-	-	-	-
CO3	-	2	-	-	-	-	-	-
CO4	-	2	-	-	-	-	-	-
CO5	-	2	-	-	-	-	-	-

Mapping of Course Outcomes with Program Specific Outcomes:

CO/PSO	PSO1	PSO2	PSO3
CO1	-	2	-
CO2	-	2	-
CO3	-	2	-
CO4	-	2	-
CO5	-	2	-

UNIT – I

Understanding Entrepreneurial Mindset: The Evolution of Entrepreneurship, Qualities, Skills, Functions of Entrepreneurs, Types of Entrepreneurs, Approaches to Entrepreneurship, Process Approach, Role of Entrepreneurship in Economic Development. The individual Entrepreneurial Mindset and Personality: The Entrepreneurial Journey, Stress and the Entrepreneur, The Entrepreneurial Ego, Entrepreneurial Motivations, Motivational Cycle, Entrepreneurial Motivational Behavior, Entrepreneurial Competencies, Entrepreneurial Stress.

UNIT – II

Strategic Perspectives in Entrepreneurship: Strategic Planning, Strategic Actions, Strategic Positioning, Business Stabilization, Building the Adaptive Firms, Understanding the Growth Stage, Internal Growth Strategies and External Growth Strategies, Unique Managerial Concern of Growing Ventures.

UNIT – III

Business Model Basics: Introduction to Business Models-Types of Business Models-Traditional v/s New age business Model, Revenue Models: Introduction of the types of revenue models, Advertising Model, Affiliate Model, Selling Real Model- Web Sales, Channel Sales, Retail Sales Model, Selling Virtual model- Freemium Model, Licensing Model, Subscription Model, aggregator business models (OLA, UBER)

UNIT – IV

Role of Technology in Business Models: Role of Technology in Business Models, Pros and Cons of using technology in business (Universality, Omnichannel, Transaction Cost Reducer, Infinite Virtual Capacity), Challenges and Risks of Implementing Technology **Segment Profiling:** Geographic / Demographic, Behavioural / Psychographic, Target Segment, Customer Segment, Size / TAM, Segment Profiling, Types of Segment Profiling, Different Approaches to Segment Profiling, Market Research Techniques for Understanding Customer Segments, Competitive Activity, Risks, Approach to deal with existing risk

UNIT – V

Evaluating Strength of Business Model: SWOT Analysis, Porter's Five Forces Analysis, Marketing Strategies-Market positioning, Tangible and perceived value of a product, Marketing strategies, Exploring International Markets and Global Expansion, Growth Potential: Target Segment Collaboration, Customer Centric, Asset-light business model, **Failure of Business model:** Reasons why does a business model fail, Approaches to revive the failure of business model

Text Books:

- 1 Robert D. Hisrich, Michael P. Peters, Dean A. Shepherd, Entrepreneurship, McGraw Hill, 10e, ISBN-10:0078029298.
- 2 The Lean Startup: How Today's Entrepreneurs Use Continuous Innovation to Create Radically Successful Businesses by Eric Ries, ISBN-9780307887894

Reference Books:

- 1 Bruce R. Barringer / R. Duane Ireland, Entrepreneurship Successfully launching new ventures, 4e, Pearson, ISBN-9780136083535.
- 2 Platform Revolution: How Networked Markets Are Transforming the Economy and How to Make Them Work for You by Geoffrey G. Parker, Marshall W. Van Alstyne, and Sangeet Paul Choudary, ISBN-978-0393249125

Web Links:

- 1 https://onlinecourses.nptel.ac.in/noc22_mg32/preview
- 2 <https://elearn.nptel.ac.in/shop/iit-workshops/ongoing/innovation-and-entrepreneurship-a-multi-disciplinary-approach/?v=c86ee0d9d7ed>

BUSINESS ETHICS AND CORPORATE GOVERNANCE

Course Code: 244MS016	L	T	P	C
	2	0	0	2

Course Outcomes:

At the end of the Course, Student will be able to:

- CO1:** Explain principles of personal and professional ethics, importance and need of business ethics
- CO2:** Identify perspective, major thrust areas and issues of Corporate Governance.
- CO3:** Apply the concepts of ethical decision making in business.
- CO4:** Analyze the factors facilitating globalization, international code of business conduct and role of ethics in the era of globalization.
- CO5:** Determine the role various corporate social responsibility initiatives in business.

Mapping of Course Outcomes with Program Outcomes:

CO/PO	PO1	PO2	PO3	PO4	PO5	PO6	PO7	PO8
CO1	-	-	-	2	-	-	-	-
CO2	-	-	-	2	-	-	-	-
CO3	-	-	-	2	-	-	-	-
CO4	-	-	-	2	-	-	-	-
CO5	-	-	-	2	-	-	-	-

Mapping of Course Outcomes with Program Specific Outcomes:

CO/PSO	PSO1	PSO2	PSO3
CO1	2	-	-
CO2	2	-	-
CO3	2	-	-
CO4	2	-	-
CO5	2	-	-

UNIT – I

Introduction to Business Ethics: Definition – Principles of Personal Ethics – Principles of Professional Ethics – The Development of Business Ethics – Importance and Need for Business Ethics – Significance of Business Ethics – Values and Ethics in Business.

UNIT – II

Corporate Governance – Definitions – Historical Perspective of Corporate Governance – Significance of Corporate Governance in Developing Countries – Issues in Corporate Governance – Major thrust areas of Corporate Governance – Indian model of Corporate Governance.

UNIT – III

Ethical Decision Making in Business – Ethical Decision making with Cross – holder conflicts and competition – Applying Moral philosophy to Ethical decision making – Kohlberg’s Model of Cognitive Moral development – Influences on Ethical Decision making

UNIT – IV

Globalization and Business Ethics – Growth of Global Corporations – Factors Facilitating Globalization – Role of Multinational Corporations – International Business Issues –

International Codes of Business conduct – Challenges of Globalization in the context of Growing market economies – Key Global issues for Business – Corporate Governance is a pre-requisite for Globalization.

UNIT – V

Corporate Social Responsibility: Definitions of CSR – Models for implementation of CSR – CSR as a business strategy for sustainable development – Advantages of CSR – Scope of CSR – Understanding Social Responsibility of Business – Protecting and Promoting stake holder’s interests.

Text Books:

- 1 M.G. Velasquez, Business Ethics, Prentice Hall India Limited, New Delhi, ISBN-978-0205217670.
- 2 Andrew Crane and Diark Matten, Business Ethics, Oxford Publication, New Delhi, ISBN-10:0198755961.

Reference Books:

- 1 Business Ethics – A Case perspective – O.C. Ferrell, John Fraedrich and Linda Ferrell Cengage Leachery, ISBN-978-0357513361.
- 2 Business Ethics – An Indian Perspective – A.C. Fernando. Pearson, ISBN-978-9353437442.

Web Links:

- 1 <https://archive.nptel.ac.in/courses/110/105/110105079/>
- 2 https://onlinecourses.swayam2.ac.in/cec19_mg24/preview

Relevant cases have to be discussed in each unit and in examination case study is compulsory from any unit.

STRATEGIC MANAGEMENT

Course Code:244MS017	L	T	P	C
	3	0	0	3

Course Outcomes:

At the end of the Course, Student will be able to:

- CO1:** Explain the strategic context and terminology and aspects of strategic planning
- CO2:** Analyze the factors involved in strategy formulation and strategic analysis.
- CO3:** Assess the various approaches to strategy implementation
- CO4:** Compare different forms of corporate restructuring
- CO5:** Analyze different techniques of strategic evaluation and control

Mapping of Course Outcomes with Program Outcomes:

CO/PO	PO1	PO2	PO3	PO4	PO5	PO6	PO7	PO8
CO1	-	-	-	-	1	-	-	-
CO2	-	-	-	-	1	-	-	-
CO3	-	-	-	-	1	-	-	-
CO4	-	-	-	-	1	-	-	-
CO5	-	-	-	-	1	-	-	-

Mapping of Course Outcomes with Program Specific Outcomes:

CO/PSO	PSO1	PSO2	PSO3
CO1	2	-	-
CO2	2	-	-
CO3	2	-	-
CO4	2	-	-
CO5	2	-	-

UNIT – I

Introduction of Strategic Management: Strategic Context and Terminology; Definition of Strategy; Difference between policy, Strategy and Tactic; strategic planning- Difference between Long Range Planning and Strategic Planning; Characteristics of Strategic Decisions.

UNIT – II

Strategy Formulation: Company Mission & Vision – Mission Statements, Company goals, philosophy, features of strategic goals. Social Responsibility and ethical decision making; analyzing the business environment: External environment; Porter’s Industry Analysis; Five forces Model. Internal Analysis of the firm, value chain analysis. **Strategic Analysis:** BCG-Growth Share Matrix-SWOT Analysis, Profit Impact of Market Strategies (PIMS), Product Market Matrix of Ansoff). Formulating Long-Term Strategies: Concentration, Market Development, Product Development, Horizontal Integration, Vertical Integration, Diversification, Liquidation, Sell-off. Generic Competitive Advantages – Cost Leadership, Differentiation & Focus; Competitive strategies in different types of industries- Fragmented, Emerging, Maturing & Declining industries.

UNIT – III

Strategy Implementation: Strategy and structure; managing strategic change; establishing strategic controls; Management tools in strategy: Benchmarking; Benchmarking practices worldwide; Reengineering-: Systematic approach, clean sheet approach, Reverse Engineering, Balanced Score card.

UNIT – IV

Corporate Restructuring Forms of corporate restructuring; Rational for existence of firms; Organizational forms; Turnaround management; Joint Ventures & Strategic Alliances: Generic motives for a strategic alliance, types of strategic alliances; managing the alliances; Mergers & Acquisitions: Rational for mergers & acquisitions; Mergers types; Divestitures & Spin-offs: Liquidations and spin-offs.

UNIT – V

Strategic Evaluation and Control Strategic Evaluation and Control: Concept, Role, and Barriers; Control Process; Techniques of Strategic Evaluation and Control.

Text Books:

- 1 Business Policy and Strategic Management- Lawrence R. Jauch., Glueck William F. (Frank Brothers), ISBN-10-0071005072
- 2 Strategic Management- Pearce II John A. and Robinson J.R. and Richard B., (AITBS), ISBN-978-0072980073.

Reference Books:

- 1 Concepts in Strategic Management and Business Policy- Wheelen Thomas L., Hunger J. David and Rangarajan Krish, (Pearson Education, 1stEd.), ISBN-13:978-0132323192.
- 2 Cases in Strategic Management- Budhiraja S.B. and Athreya M.B, (Tata McGraw Hill, 1st Ed.), ISBN-978-0074620977
- 3 Competitive Strategy by Michael E. Porter, ISBN-978-1416590354.

Web Links:

- 1 <https://archive.nptel.ac.in/courses/110/108/110108047/>
- 2 <https://archive.nptel.ac.in/courses/110/105/110105161/>

Relevant cases have to be discussed in each unit and in examination case study is compulsory from any unit.

MANAGING INFORMATION SYSTEMS

Course Code:244MS018	L	T	P	C
	2	0	0	2

Course Outcomes:

At the end of the Course, Student will be able to:

- CO1:** Identify the information needs of an organization and a business function
- CO2:** Assess effectiveness of decision-making process and MIS design
- CO3:** Analyze DSS techniques for making effective decisions
- CO4:** Appraise the parameters for information systems process and application
- CO5:** Apply DBMS to attain the goals of the organization

Mapping of Course Outcomes with Program Outcomes:

CO/PO	PO1	PO2	PO3	PO4	PO5	PO6	PO7	PO8
CO1	-	2	-	-	-	-	-	-
CO2	-	2	-	-	-	-	-	-
CO3	-	2	-	-	-	-	-	-
CO4	-	2	-	-	-	-	-	-
CO5	-	2	-	-	-	-	-	-

Mapping of Course Outcomes with Program Specific Outcomes:

CO/PSO	PSO1	PSO2	PSO3
CO1	-	2	-
CO2	-	2	-
CO3	-	2	-
CO4	-	2	-
CO5	-	2	-

UNIT – I

Management Information System; Basic Concepts – Organization Structure – Business Functions – Role of MIS – MIS in Business - MIS Developing Process Models - Simon’s Model in Information System – Major Trends in Information Technology.

UNIT – II

Managerial Decision Making and MIS Design: Decision Making Process; Relationship between Decision-Making and MIS; Group Decision Making - Integrating Managerial Levels and Functional areas by MIS-Components of MIS. System and Design; Systems Development Initiate

UNIT – III

Different Methodologies: System Life Cycle Design - Prototype Approach - System Implementation. Decision Support System; Definitions of DSS – Architecture of DSS - Scope of DSS - Characteristic and Capabilities of DSS - Components of DSS – Modules in DSS- Classification of DSS – Steps in Designing a DSS.

UNIT – IV

Information System Applications and Process: MIS applications, DSS – GDSS - DSS applications in E enterprise - Knowledge Management System and Knowledge Based Expert System, Enterprise Model System and E-Business, E- Commerce, E-communication, Business

Process Reengineering. Technology of information system: Data process- Transaction and application process; Unified communication and network; Security challenges in E-enterprises; Security threats and vulnerability-Controlling security threat and vulnerability.

UNIT – V

Data Base Management System: Objectives of data base approach- Characters of database, Management systems- Data processing system- Components of DBMS packages, Data base administration, Data models, Data warehouse.

Text Books:

- 1 Jawadekar, Management Information System, Tata McGraw Hill, 7th Edition, New Delhi, ISBN-1259026698.
- 2 Arora, Management Information System, Excel Books, 4th Edition, New Delhi, ISBN-9788174462534.

Reference Books:

- 1 C.S.V. Murthy, Management Information System, Himalaya Publishing House, 11 Edition, Mumbai, ISBN-10:8184882750.
- 2 Goyal, D.P.: “Management Information System”, MACMILLAN India Limited, New Delhi, ISBN-10:9325978601.

Web Links:

- 1 https://onlinecourses.nptel.ac.in/noc20_mg60/preview
- 2 <https://archive.nptel.ac.in/courses/122/105/122105022/>

Relevant cases have to be discussed in each unit and in examination case study is compulsory from any unit.

BUSINESS TAXATION

Course Code:244MS019	L	T	P	C
	2	1	0	3

Course Outcomes:

At the end of the Course, Student will be able to:

- CO1:** Explain the tax system in India, including the structure and powers of the Union and States to levy taxes.
- CO2:** Analyze the provisions related to small-scale industries and exports under Central Excise.
- CO3:** Assess various infringements of customs law, including offenses and penalties.
- CO4:** Analyze the impact of GST on businesses, including the impact on pricing, supply chain, and tax compliance.
- CO5:** Evaluate the assessment proceedings under GST, including the filing of returns and refunds.

Mapping of Course Outcomes with Program Outcomes:

CO/PO	PO1	PO2	PO3	PO4	PO5	PO6	PO7	PO8
CO1	2	-	-	-	-	-	-	-
CO2	2	-	-	-	-	-	-	-
CO3	2	-	-	-	-	-	-	-
CO4	2	-	-	-	-	-	-	-
CO5	2	-	-	-	-	-	-	-

Mapping of Course Outcomes with Program Specific Outcomes:

CO/PSO	PSO1	PSO2	PSO3
CO1	2	-	-
CO2	2	-	-
CO3	2	-	-
CO4	2	-	-
CO5	2	-	-

UNIT – I

Introduction: Objectives of Taxation - Canons of Taxation - Tax system in India - Direct and Indirect Taxes - Meaning and Types - Powers of Union and States to levy taxes.

UNIT – II

Central Excise Duty: Classification - Levy and Collection of Excise Duty - Clearance of Excisable goods - Exemption from Excise Duty - Excise and Small-Scale Industries - Excise and Exports - Demand, Refund, Rebate of Central Excise Duty - Offences and Penalties - Settlement - Appellate Provisions.

UNIT – III

Customs Duty: Meaning - Levy and Collection of Customs Duty - Organization of the Customs Department - Officers of the Customs - Powers - Appellate machinery - Infringement of the law - Offences and Penalties - Exemption from Duty - Customs Duty Drawback - Duty Free Zones.

UNIT – IV

GST - Background behind implementing GST - The need for GST- Business impact Benefits of GST-SGST-CGST and IGST - Taxes covered by GST- Definitions - Scope and Coverage Scope of supply-Levy of tax - Rate Structure -Taxable Events.

UNIT – V

GST - Assessment Proceedings - Return - Refunds - Input Tax Credit - Reverse charge Mechanism, Transitional Provisions composition under GST- Administrative structure of GST - Officers as per CGST Act - Officers as per SGST Act - Jurisdiction - Appointment Powers.

Text Books:

- 1 Students' Guide to Income Tax, Dr. Vinod K. Singhania & Dr. Monica Singhania, ISBN-13:978-9391596415.
- 2 Direct taxes law & practice, Dr. Vinod K. Singhania & Dr. Kapil Singhania Ahuja Girish and Ravi Gupta, Bharat Law House, Delhi, ISBN-13:978-9356039872.

Reference Books:

- 1 GST Made Easy, Haldia, Arpit, Taxmann Publications, ISBN-10-978-9390585892.
- 2 Students' Handbook on Goods and Services Tax, Hiregange, Jain and Naik, Puliani and Puliani.

Web Links:

- 1 <https://www.youtube.com/watch?v=swrzarYcMvY>
- 2 https://www.youtube.com/watch?v=QUI_OevD3yw

Relevant cases have to be discussed in each unit and in examination case study is compulsory from any unit.

INVESTMENT ANALYSIS AND PORTFOLIO MANAGEMENT

	L	T	P	C
Course Code:244MS023	3	0	0	3

Course Outcomes:

At the end of the Course, Student will be able to:

- CO1:** Identify the Indian Financial System, investment distinctions, and SEBI's roles.
- CO2:** Analyze risk and return, and evaluate portfolios using the CAPM.
- CO3:** Examine bond valuation and analyze bond management strategies.
- CO4:** Apply equity valuation models and analyze equity using various analytical methods.
- CO5:** Assess mutual fund performance and evaluate using performance models

Mapping of Course Outcomes with Program Outcomes:

CO/PO	PO1	PO2	PO3	PO4	PO5	PO6	PO7	PO8
CO1	-	2	-	-	-	-	-	-
CO2	-	2	-	-	-	-	-	-
CO3	-	2	-	-	-	-	-	-
CO4	-	2	-	-	-	-	-	-
CO5	-	2	-	-	-	-	-	-

Mapping of Course Outcomes with Program Specific Outcomes:

CO/PSO	PSO1	PSO2	PSO3
CO1	2	-	-
CO2	2	-	-
CO3	2	-	-
CO4	2	-	-
CO5	2	-	-

UNIT – I

Introduction to Investment: Introduction, Indian Financial System and Structure, Investment, Speculation and Gambling, Features of Investment, Investment Avenues, Investment Process. The Investment Environment, Securities Market of India, Securities Trading and Settlement, Types of Orders, Margin Trading, Roles and Responsibilities of SEBI.

UNIT – II

Portfolio Analysis: Risk and Return Analysis, Markowitz Portfolio Theory, Mean – Variance Approach, Portfolio Selection, Efficient Portfolios, Single Index Model, Capital Asset Pricing Model, Arbitrage Pricing Theory.

UNIT – III

Bond Valuation: Classification of Fixed Income Securities, Types of Bonds, Interest Rates, Term Structure of Interest Rates, Measuring Bond Yields, Yield to Maturity, Yield to Call, Holding Period Return, Bond Pricing Theorems, Bond Duration, Modified Duration. Active and Passive Bond Management Strategies, Bond immunization, Bond Volatility, Bond Convexity.

UNIT – IV

Equity Valuation: a) Intrinsic Value versus Market Value, Equity Valuation Models- Discounted Cash Flow Techniques, Dividend Discount Models (DDM), Growth Rate cases for DDM, Free Cash Flow Valuation Approaches, Relative Valuation Techniques, Earnings Multiplier Approach, Price/ Earnings, Price/ Book Value, Price/ Sales Ratio, EVA. b) Fundamental Analysis, Technical Analysis, Efficient Market Hypothesis.

UNIT – V

Performance Evaluation: Mutual Funds, Types of Mutual Funds Schemes, Structure, Trends in Indian Mutual Funds, Net Asset Value, Risk and Return, Performance Evaluation Models: Sharpe Model, Treynor Model, Jensen Model, Fama's Decomposition

Text Books:

1. ZVI Bodie, Alex Kane, Alan J Marcus, Pitabas Mohanty Investments, McGraw Hill, 11 e, ISBN-13:978-8194113850.
2. Shalini Talwar, Security Analysis and Portfolio Management, Cengage Learning, ISBN-13:978-8131524497.

Reference Books:

1. Punithavathy Pandian, Security Analysis & Portfolio Management, Vikas, ISBN-10:9325963086.
2. William. F. Sharpe, Gordon J Alexander & Jeffery V Bailey: Fundamentals of Investments, Prentice Hall, ISBN-13:-:978-0132926171.

Web Links:

1. https://onlinecourses.nptel.ac.in/noc21_mg99/preview
2. https://onlinecourses.nptel.ac.in/noc23_mg62/preview

Relevant cases have to be discussed in each unit and in examination case study is compulsory from any unit.

BANKING AND FINANCIAL INSTITUTIONS

	L	T	P	C
Course Code:244MS024	3	0	0	3

Course Outcomes:

At the end of the Course, Student will be able to:

- CO1:** Identify the evolution of banking and role of RBI in the Indian financial system.
- CO2:** Analyze and evaluate the structure and functions of RBI and commercial banks
- CO3:** Apply asset/liability management practices and analyze credit risk management models.
- CO4:** Choose the origin, growth, and lending policies of term lending institutions.
- CO5:** Develop new financial instruments and evaluate SEBI and RBI guidelines.

Mapping of Course Outcomes with Program Outcomes:

CO/PO	PO1	PO2	PO3	PO4	PO5	PO6	PO7	PO8
CO1	-	-	-	2	-	-	-	-
CO2	-	-	-	2	-	-	-	-
CO3	-	-	-	2	-	-	-	-
CO4	-	-	-	2	-	-	-	-
CO5	-	-	-	2	-	-	-	-

Mapping of Course Outcomes with Program Specific Outcomes:

CO/PSO	PSO1	PSO2	PSO3
CO1	2	-	-
CO2	2	-	-
CO3	2	-	-
CO4	2	-	-
CO5	2	-	-

UNIT – I

Financial System in India: Introduction - Evolution of Banking - Phases of development - RBI and the Financial System - Committees on Banking Sector Reforms - Prudential Banking -RBI Guidelines and directions.

UNIT – II

RBI and Commercial Banks: Introduction - Origination, Structure and Functions of RBI and Commercial Banks - Role of RBI and Commercial Banks - Lending and Operation policies - Banks as Intermediaries - NBFCs - Growth of NBFCs - FDI in Banking Sector - Banking Regulations - Law and Practice

UNIT – III

Risk Management in Banks: Introduction - Asset/Liability Management Practices - Credit Risk Management - Credit Risk Models - Country Risk Management - Insurance Regulations and Development Authority (IRDA).

UNIT – IV

Financial Institutions and Development Banking: Introduction - Origin, Growth and Lending Policies of Terms lending Institutions - Working of IDBI - IFCI - STCs - SIDBI - LIC - GIC - UTI - Role of Financial Institutions in Capital Market.

UNIT – V

New Financial Instruments and Institutions: Private Banks - Old generation and new generation private banks - Foreign Banks - NSE - Depositories - DFHI - New Equity and Debt Instruments - SEBI and RBI guidelines.

Text Books:

1. Koch W Timothy and Scott S Macdonald, "Bank Management" Thomson (South-Western), Bangalore (Text Book), ISBN-13:978-1133494683.
2. Khan M Y., "Indian Financial System", Tata McGraw Hill, New Delhi, ISBN-13:9353167302.

Reference Books:

1. Srivastava, RM., "Management of Indian Financial Institutions", Himalaya Publishing House, Mumbai, ISBN-13:978-8184880274.
2. Avadhani V A., "Investments and Securities Markets in India", Himalaya Publishing House, Mumbai, ISBN-978-93-5262-391-4.

Web Links:

1. <https://archive.nptel.ac.in/courses/110/105/110105121/>
2. https://onlinecourses.nptel.ac.in/noc22_hs72/preview

Relevant cases have to be discussed in each unit and in examination case study is compulsory from any unit.

FINANCIAL MODELLING

	L	T	P	C
Course Code: 244MS025	2	0	1	3

Course Outcomes:

At the end of the Course, Student will be able to:

- CO1:** Apply tools and techniques of financial modeling using MS Excel.
- CO2:** Analyze financial statements and perform financial ratio analysis
- CO3:** Estimate project finance decisions using time value of money and cost of capital
- CO4:** Assess the financial statements for equity research analysis.
- CO5:** Apply discounted cash flow and relative valuation methods to prepare valuation models.

Mapping of Course Outcomes with Program Outcomes:

CO/PO	PO1	PO2	PO3	PO4	PO5	PO6	PO7	PO8
CO1	-	2	-	-	-	-	-	-
CO2	-	2	-	-	-	-	-	-
CO3	-	2	-	-	-	-	-	-
CO4	-	2	-	-	-	-	-	-
CO5	-	2	-	-	-	-	-	-

Mapping of Course Outcomes with Program Specific Outcomes:

CO/PSO	PSO1	PSO2	PSO3
CO1	-	2	-
CO2	-	2	-
CO3	-	2	-
CO4	-	2	-
CO5	-	2	-

UNIT – I

Financial Modeling: Definition, Tools or Techniques of Financial Modeling – Uses and Limitations– Applications and Types of Financial Models - Process of Financial Model Development.
MS Excel for financial Modeling: Formatting of Excel Sheets - Use of Excel Formula Function - Advanced Modelling Techniques- Extrapolation, Histogram - Data Filter and Sort- Charts and Graphs- Table formula and Scenario building. Lookups: VLOOKUP, Match & offset, pivot tables

UNIT – II

Analysis of Financial Statements: Introduction to Financial Statement Analysis - Financial Reporting Mechanics - Understanding Income Statement, Balance Sheet - Cash Flow Statement - Financial Analysis Techniques - Inventories, Long Lived Assets - Non-Current Liabilities - Financial Statement Application. Financial Ratios: Ratio analysis of industries - Du point Analysis - Peer to peer analysis - Preparation of Financial Analysis report on an industry

UNIT – III

Business Finance: Time value of money - long term financing - Cost of capital - Measure of Leverage Project Finance - Project evaluation; stage of project; construction & development phase; funding during investment phase - Costs during investment phase - Life of project -

Decision making - Cash flow waterfall & resolve circular reference problem in interest during construction.

UNIT – IV

Equity Research Modelling: Prepare an Income Statement, Balance sheet, Cash Flow Statement, Geographic Revenue Sheet, Segment Revenue Sheet, Cost Statement, Debt Sheet, Analyze Revenue Drivers - Forecast Geographic & Segment Revenues, Cost Statement, Debt, Income Statement, Balance Sheet, and Cash Flow Statement. - Perform Adjustments, Income Statement - Compute Margins, Balance Sheet - Compute Ratios - Cash Flow Statement Projection.

UNIT – V

Valuation: Discounted Cash Flow Method (DCF), Valuation – Relative Valuation (Football Field Chart) - Valuation – Assumptions for Valuation Model, Prepare Valuation Model, Prepare Presentation Sheet, Prepare Company Overview, Sector Overview

Text Books:

1. Building Financial Models with Microsoft Excel: A Guide for Business Professionals, by K. Scott Proctor, ISBN-10:978-8126525157.
2. Principles of Financial Modelling: Model Design and Best Practices Using Excel and VBA, by Michael Rees, ISBN-13:978-1118904015.

Reference Books:

1. Financial Modelling by Simon Banning, ISBN-10:0262027283.
2. Financial Modelling by Paul Pignataro, ISBN-13:978-1118558768.

Web Links:

1. <https://www.coursera.org/specializations/wharton-business-financial-modeling>
2. https://onlinecourses.nptel.ac.in/noc21_mg93/preview

Relevant cases have to be discussed in each unit and in examination case study is compulsory from any unit.

MERGERS, ACQUISITIONS AND CORPORATE RESTRUCTURING

	L	T	P	C
Course Code: 244MS026	3	0	0	3

Course Outcomes:

At the end of the Course, Student will be able to:

- CO1:** Compare the impact of different types of mergers on stakeholders
- CO2:** Develop strategic M&A decisions using industry life cycle, product life cycle analysis
- CO3:** Construct a comprehensive merger process plan, incorporating target identification
- CO4:** Analyze methods of financing mergers and their implications on capital budgeting decisions
- CO5:** Assess the significance and various forms of corporate restructuring.

Mapping of Course Outcomes with Program Outcomes:

CO/PO	PO1	PO2	PO3	PO4	PO5	PO6	PO7	PO8
CO1	2	-	-	-	-	-	-	-
CO2	2	-	-	-	-	-	-	-
CO3	2	-	-	-	-	-	-	-
CO4	2	-	-	-	-	-	-	-
CO5	2	-	-	-	-	-	-	-

Mapping of Course Outcomes with Program Specific Outcomes:

CO/PSO	PSO1	PSO2	PSO3
CO1	2	-	-
CO2	2	-	-
CO3	2	-	-
CO4	2	-	-
CO5	2	-	-

UNIT – I

Mergers- types of mergers– theories of mergers- operating, financial and managerial synergy of mergers – value creation in horizontal, vertical and conglomerate mergers – internal and external change forces contributing to M & A activities- Impact of M & A on stakeholders.

UNIT – II

M & A – A Strategic Perspective- industry life cycle and product life cycle analysis in M&A decision, strategic approaches to M&A- SWOT analysis, BCG matrix. Takeovers, types, takeover strategies, - Takeover defenses – financial defensive measures – methods of resistance – anti-takeover amendments – poison pills Legal aspects of Mergers/amalgamations and acquisitions/takeovers- Combination and Competition Act- Competition Commission of India (CCI), The SEBI Substantial Acquisition of Shares and Takeover code.

UNIT – III

Merger Process: Dynamics of M&A process - identification of targets – negotiation - closing the deal. Five-stage model – Due diligence– Types - due diligence strategy and process - due diligence challenges. Process of merger integration – organizational and human aspects –

managerial challenges of M & A.

UNIT – IV

Methods of Financing Mergers – cash offer, share exchange ratio – mergers as a capital budgeting decision Synergies from M&A: Operating and Financial synergy Accounting for amalgamation – amalgamation in the nature of merger and amalgamation in the nature of purchase- pooling of interest method, purchase method – procedure laid down under Indian companies act of 2013.

UNIT – V

Corporate Restructuring – significance - forms of restructuring – joint ventures – sell off and spin off – divestitures – equity carve out – leveraged buy outs (LBO) – management buy outs – master limited partnership– Limited Liability Partnership (LLP) in India: Nature and incorporation of LLP-De merger- strategic alliance buyback of shares.

Text Books:

1. Value Creation from Mergers and Acquisitions, Sudi Sudarsanam – 1/e, Pearson Education, ISBN-13: 978-0273715399.
2. Merger Acquisitions & Corporate Restructuring – Chandrashekar Krishna Murthy & Vishwanath. S.R – Sage Publication, ASIN-076193586X.

Reference Books:

1. Mergers, acquisitions and Corporate Restructuring, Nishikant Jha, Himalaya Publishing House, ISBN-978-93-6061-035-3.
2. Corporate Restructuring, Bhagaban Das, Debdas Raskhit and Sathya Swaroop Debasish, Himalaya Publishing, ISBN-10:8184885822.

Web Links:

1. <https://nptel.ac.in/courses/110105165>
2. <https://www.coursera.org/specializations/mergersandacquisitions>

Relevant cases have to be discussed in each unit and in examination case study is compulsory from any unit.

FINANCIAL RISK MANAGEMENT AND FINANCIAL DERIVATIVES

Course Code: 244MS027

L	T	P	C
3	0	0	3

Course Outcomes:

At the end of the Course, Student will be able to:

- CO1:** Analyze various types of risks and their measurement, and evaluation.
- CO2:** Apply concepts of Economic Capital and RAROC to measure and manage credit.
- CO3:** Estimate the use of forward and futures contracts.
- CO4:** Explain the mechanics and types of swaps, and assess their application.
- CO5:** Compare and analyze options and their pricing.

Mapping of Course Outcomes with Program Outcomes:

CO/PO	PO1	PO2	PO3	PO4	PO5	PO6	PO7	PO8
CO1	2	-	-	-	-	-	-	-
CO2	2	-	-	-	-	-	-	-
CO3	2	-	-	-	-	-	-	-
CO4	2	-	-	-	-	-	-	-
CO5	2	-	-	-	-	-	-	-

Mapping of Course Outcomes with Program Specific Outcomes:

CO/PSO	PSO1	PSO2	PSO3
CO1	2	-	-
CO2	2	-	-
CO3	2	-	-
CO4	2	-	-
CO5	2	-	-

UNIT – I

Introduction: The concept of Risk- Nature- Need and scope of risk. Source- measurement- identification and evaluation of Risk. Types of risk–Credit, Market, operational risk, Possible Risk events- Risk Indicators. Risk management approaches and methods. Risk reporting process– internal and external.

UNIT – II

Risk Measurement at Corporate Level: Economic capital and RAROC. -Introduction-Meaning of Economic Capital-Probability of Default-Using Risk Adjusted Performance for Business Decisions- Measuring Credit Risk-Measuring Market Risk and measuring operational risk Value at risk (VaR): The concept, Historical Simulation, Monte Carlo simulation, stress testing, back testing

UNIT – III

Forwards: features and pay-off profile of Forward contract. Valuation of forward contracts. Forward Contracts to manage Commodity price risk- Interest rate risk and exchange rate risk. Limitations of Forward contract. **Futures:** Definition. Clearing house- margin requirements- marking to market. Basis and convergence of future price to spot price. Valuation of Futures contract. Differences between forward contracts and futures contracts. Risk management with Futures contracts–hedge ratio and portfolio approach to a risk–minimizing hedge.

UNIT – IV

Swaps: Definition- Introduction to types of swaps like Simple Plain Swaps, Interest rate swaps, currency swaps, and others like Accrediting, Amortizing and Roller Coaster Swaps, Basis Swap, CMT Swaps, Total Return Swaps, Credit Default Swaps. Mechanics of Interest rate Swaps and currency swaps.

UNIT – V

Options: Definition - Types - call option- put option- American option and European option. Options- in the money-at the money and out of the money. Option premium- intrinsic value and time value of options. Pricing of call and put options at expiration and before expiration. Options on stock indices and currencies. Introduction to Greeks, Black & Scholes option pricing model (BSOPM): assumptions.

Text Books:

1. Dun and Bradstreet, Financial Risk Management, Tata McGraw hill, ISBN-13:978-0070611498.
2. John C. Hull Sankarshan Basu, Options, Futures and Other Derivatives, Pearson Education, ISBN-13:978-9392970962.

Reference Books:

1. Paul Hopkins, Kogan Page, Fundamentals of Risk Management, Institute of Risk Management, ISBN-13:978-0749483074.
2. Robert A Strong: Derivatives – An Introduction, Thomson, ISBN-9780324273021.

Web Links:

1. <https://archive.nptel.ac.in/courses/110/107/110107128/>
2. https://onlinecourses.nptel.ac.in/noc22_mg91/preview

Relevant cases have to be discussed in each unit and in examination case study is compulsory from any unit.

INTERNATIONAL FINANCE

Course Code: 244MS028	L	T	P	C
	3	0	0	3

Course Outcomes:

At the end of the Course, Student will be able to:

- CO1:** Explain the nature, scope, and challenges of International Financial Management
- CO2:** Analyze the evolution and current structure of the International Monetary System
- CO3:** Identify the function and structure of the foreign exchange market
- CO4:** Apply knowledge of exchange rate movements, government influence, and arbitrage.
- CO5:** Develop strategies for effective asset-liability management, international capital budgeting, and financing, including portfolio and cash management techniques.

Mapping of Course Outcomes with Program Outcomes:

CO/PO	PO1	PO2	PO3	PO4	PO5	PO6	PO7	PO8
CO1	2	-	-	-	-	-	-	-
CO2	2	-	-	-	-	-	-	-
CO3	2	-	-	-	-	-	-	-
CO4	2	-	-	-	-	-	-	-
CO5	2	-	-	-	-	-	-	-

Mapping of Course Outcomes with Program Specific Outcomes:

CO/PSO	PSO1	PSO2	PSO3
CO1	2	-	-
CO2	2	-	-
CO3	2	-	-
CO4	2	-	-
CO5	2	-	-

UNIT – I

Introduction: Nature and Scope of International Financial Management, Domestic FM Vs. IFM, Challenges in International Financial Management. International Flow of Funds: Balance of Payments (BOP), Accounting Components of BOP, Factors affecting International Trade Flows, Agencies that facilitate International Flows. Payment methods of International Trade, Trade Finance Methods, EXIM Bank of India, Amendments in EXIM policy, Regulations and Guidelines.

UNIT – II

International Monetary System: Evolution, Gold Standard, Bretton Woods’s System, the Flexible Exchange Rate Regime, Evaluation of Floating Rates, the Current Exchange Rate arrangements, the Economic and Monetary Union (EMU) and Developments.

UNIT – III

Foreign Exchange Market: Function and Structure of the Forex Markets, Major Participants, Types of Transactions and Settlements Dates, Foreign Exchange Quotations. Process of Arbitrage, Speculation in the Forward Market. Currency Futures and Options Markets, Overview of the other markets, Euro Currency Market, Euro Credit Market, Euro Bond Market, International Stock Market.

UNIT – IV

Exchange Rates: Measuring Exchange Rate Movements, Factors influencing Exchange Rates. Government influence on Exchange Rates, Exchange Rate Systems. Managing Foreign Exchange Risk. International Arbitrage and Interest Rate Parity. Relationship between Inflation, Interest Rates and Exchange Rates, Purchasing Power Parity, International Fisher Effect, Fisher Effect, Interest Rate Parity, Expectations Theory

UNIT – V

Asset–Liability Management: Foreign Direct Investment, International Capital Budgeting, International Capital Structure and Cost of Capital. International Portfolio Management. International Financing: Equity, Bond Financing, Parallel Loans, International Cash Management, Accounts Receivable Management, Inventory Management.

Text Books:

1. O P Agarwal International Financial Management, 3rd Edition HPH, ISBN-978-93-5273-866-3.
2. Gupta Shashi K., Rangi Praneet International Finance 2nd Edition, Kalyani Publishers, ISBN-9789352605484.

Reference Books:

1. Eun C.S., Resnick B.G., “International Financial Management”, Tata McGraw Hill Education Pvt. Ltd., 4th Ed. Special Indian Edition, ISBN-13:978-0077861605.
2. Shailaja G, “International Finance”, 2nd Ed. Orient Black ‘swan, ISBN-9788173717475.

Web Links:

1. https://ugcmoocs.inflibnet.ac.in/index.php/courses/view_pg/733
2. https://onlinecourses.nptel.ac.in/noc23_mg30/preview

Relevant cases have to be discussed in each unit and in examination case study is compulsory from any unit.

BEHAVIORAL FINANCE

	L	T	P	C
Course Code: 244MS029	3	0	0	3

Course Outcomes:

At the end of the Course, Student will be able to:

- CO1:** Explain the nature, scope, objectives, and applications of behavioral finance
- CO2:** Analyze Expected Utility Theory and other decision-making theories under risk and uncertainty
- CO3:** Estimate the impact of behavioral factors on financial markets
- CO4:** Apply behavioral factors to corporate finance decisions
- CO5:** Identify the experimental approaches to measure and understand the emotional and neuro physiological mechanisms

Mapping of Course Outcomes with Program Outcomes:

CO/PO	PO1	PO2	PO3	PO4	PO5	PO6	PO7	PO8
CO1	-	2	-	-	-	-	-	-
CO2	-	2	-	-	-	-	-	-
CO3	-	2	-	-	-	-	-	-
CO4	-	2	-	-	-	-	-	-
CO5	-	2	-	-	-	-	-	-

Mapping of Course Outcomes with Program Specific Outcomes:

CO/PSO	PSO1	PSO2	PSO3
CO1	2	-	-
CO2	2	-	-
CO3	2	-	-
CO4	2	-	-
CO5	2	-	-

UNIT – I

Introduction to Behavioral finance: Nature, scope, objectives and application; Investment Decision Cycle: Judgment under Uncertainty :Cognitive information perception - Peculiarities (biases) of quantitative and numerical information perception - Weber law Subjective probability – Representativeness – Anchoring - Asymmetric perception of gains and losses framing and other behavioral effects - Exponential discounting - Human economic behavior - Discount factors for short and long horizons - Experimental measurement of the discount factor - Hyperbolic discounting.

UNIT – II

Utility/ Preference Functions: Expected Utility Theory [EUT] and Rational Thought: Decision making under risk and uncertainty - Expected utility as a basis for decision-making – Theories based on Expected Utility Concept – Decision making in historical prospective - Allais and Elsborg ‘s Paradoxes - Rationality from an economics and evolutionary prospective – Herbert Simon and bounded rationality- Investor rationality and market efficiency - Empirical data that questions market efficiency.

UNIT – III

Behavioral Factors and Financial Markets: The Efficient Markets Hypothesis – Fundamental Information and Financial Markets - Information available for Market Participants and Market

Efficiency -Market Predictability –The Concept of limits of Arbitrage Model - Asset management and behavioral factors - Active Portfolio Management: return statistics and sources of systematic underperformance. - Fundamental information and technical analysis – the case for psychological influence

UNIT – IV

Behavioral Corporate Finance: Behavioral factors and Corporate Decisions on Capital Structure and Dividend Policy - Capital Structure dependence on Market Timing - Mergers and Acquisitions. Systematic approach to using behavioral factors in corporate decision making. External Factors and Investor Behavior: Mechanisms of the External Factor influence on risk perception and attitudes - Connection to human psychophysiology and emotional regulation Active portfolio management – the source of the systematic underperformance.

UNIT – V

Emotions and Decision-Making: Experimental measurement of risk-related - Measuring Risk - Emotional mechanisms in modulating risk-taking attitude - Neurophysiology of risk taking. Personality traits and risk attitudes in different domains.

Text Books:

1. Behavioral Finance: Psychology, Decision-Making, and Markets", by Ackert and Deaves, ISBN-9780324661170.
2. The Psychology of Investing by John R, ISBN-10:0367748185.

Reference Books:

1. Understanding Behavioral Finance by Ackert Nofsinger, Pearson Prentice Hall, (4th Edition) , ISBN-9788131515440.
2. What Investors Really Want - Learn the lessons of behavioral Finance, Meir Statman, McGraw-Hill, ISBN-9780071741651.

Web Links:

1. https://onlinecourses.nptel.ac.in/noc23_mg38/preview
2. <https://www.coursera.org/learn/duke-behavioral-finance>

Relevant cases have to be discussed in each unit and in examination case study is compulsory from any unit.

FINANCIAL ANALYTICS

	L	T	P	C
Course Code: 244MS030	2	0	1	3

Course Outcomes:

At the end of the Course, Student will be able to:

- CO1:** Identify financial statements to interpret organizational financial health.
- CO2:** Apply time value of money and risk-return measures to make financial decisions.
- CO3:** Analyze investment opportunities using capital budgeting techniques
- CO4:** Assess equity valuations and perform industry, economic, and technical analysis.
- CO5:** Examine bond valuation and immunization strategies to manage fixed-income portfolios effectively.

Mapping of Course Outcomes with Program Outcomes:

CO/PO	PO1	PO2	PO3	PO4	PO5	PO6	PO7	PO8
CO1	-	2	-	-	-	-	-	-
CO2	-	2	-	-	-	-	-	-
CO3	-	2	-	-	-	-	-	-
CO4	-	2	-	-	-	-	-	-
CO5	-	2	-	-	-	-	-	-

Mapping of Course Outcomes with Program Specific Outcomes:

CO/PSO	PSO1	PSO2	PSO3
CO1	2	-	-
CO2	2	-	-
CO3	2	-	-
CO4	2	-	-
CO5	2	-	-

UNIT – I

Techniques of Financial Statement: Horizontal, Vertical Analysis, Trend Analysis, Ratio Analysis, Liquidity, Profitability, Solvency and Turnover Ratio, Valuation of Ratios, Statement of Cash Flow, Classification of Cash Flow, Computing Net Cash Flow: Operating, Investing and Financing Activities. Reporting and Interpretation using Spreadsheet.

UNIT – II

Time Value of Money: Future Value: Simple, Compound Interest and Annuity, Present Value: Discounted, Annuity, Equated Loan Amortization, Perpetuity using Spreadsheets. **Risk and Return:** Holding Period Returns, Arithmetic Mean vs Geometric Mean, Risk: Standard Deviation, Coefficient of Variation, Beta, and Covariance of Stock.

UNIT – III

Capital Budgeting Techniques: Payback Period, Accounting Rate of Return, Net Present Value, Internal Rate of Return, Profitability Index, Decision Tree, Cash Flow in Capital Budgeting, Cost of Capital, Advance Capital Budgeting Techniques, Adjusted Present Value Approach, Competing Project Risk using Spreadsheets.

UNIT – IV

Equity Valuation: Calculation of Portfolio Mean and Variance, Capital Asset Pricing Model (CAPM), Variance: Covariance Matrix, Estimating Beta and Security Market Line. Industry Analysis, Economic Analysis and Technical Analysis in Stock, Real Option in Capital Budgeting.

UNIT – V

Bond Valuation: Duration, Duration of Bond with Uneven Payments, Immunization Strategies, Modelling the Term Structure, Calculating Expecting Bond Return in a Single and Multi-period Framework, Semi-annual Transition Matrix, Computation of Bond Beta.

Text Books:

1. Financial analytics with R by Mark J. Bennett, Dirk L. Hugen, Cambridge university Press, ISBN-9781107150751.
2. Haskell Financial Data Modelling and Predictive Analytics Paperback – Import, By Pavel Ryzhov, ISBN-9781782169437.

Reference Books:

1. Quantitative Financial Analytics: The Path to Investment Profits Paperback – Import by Edward E Williams (Author), John A Dohelman, ISBN-981322424X.
2. N R Parasuraman, Financial Management-step by step approach, Cengage, 1e, ISBN-13:978-8131520987.

Web Links:

1. https://onlinecourses.nptel.ac.in/noc23_mg12/preview
2. <https://www.udemy.com/course/intro-to-business-models-financial-modelling-valuation/>

Relevant cases have to be discussed in each unit and in examination case study is compulsory from any unit.

SALES AND RETAIL MANAGEMENT

	L	T	P	C
Course Code: 244MS031	3	0	0	3

Course Outcomes:

At the end of the Course, Student will be able to:

- CO1:** Explain the scope and evolution of retail management.
- CO2:** Differentiate between store-based and non-store-based retail formats.
- CO3:** Apply site analysis techniques for selecting retail locations.
- CO4:** Analyze merchandise buying systems and apply market segmentation concepts
- CO5:** Compare traditional and e-retailing methods and assess the impact of in-store technologies.

Mapping of Course Outcomes with Program Outcomes:

CO/PO	PO1	PO2	PO3	PO4	PO5	PO6	PO7	PO8
CO1	2	-	-	-	-	-	-	-
CO2	2	-	-	-	-	-	-	-
CO3	2	-	-	-	-	-	-	-
CO4	2	-	-	-	-	-	-	-
CO5	2	-	-	-	-	-	-	-

Mapping of Course Outcomes with Program Specific Outcomes:

CO/PSO	PSO1	PSO2	PSO3
CO1	2	-	-
CO2	2	-	-
CO3	2	-	-
CO4	2	-	-
CO5	2	-	-

UNIT – I

Introduction - Definition - scope – Characteristics – Evolution – Functions – The retailing process - Managing a retail store / chain - Classification of retail formats - Private label brands or store brands - Retail industry in India - Principles – Retail Sales Goals – Retailing in India – Retailing across the Globe – Global Retailing Trends – Reasons for Retail Growth – Emerging Trends

UNIT – II

Delivering Value Through Retail Formats: Store Based Retail Formats – Retail Sale by Ownership – On the Basis of Merchandise Offered (Food Based Retailer and General Merchandise Retailers). Non– Store Based (Traditional) Retail Mix and Non– Traditional Selling – Traditional Retailing, non – Traditional Retailing and Emerging Retail Formats.

UNIT – III

Deciding Location: Store Location – Introduction – Importance – Target and Store Location – Selection of Location – Site Analysis – Trading Area Analysis – Demand Density – Supply Density – Site Availability – Common Errors – Recent Trends in Store Location. Supply Chain Management – The Supply Chain – Evolution – Why SCM – Innovation in SCM – Hierarchy of Supply Chain Decisions – Warehousing – Major Drivers of Supply Chain – Components of Supply Chain.

UNIT – IV

Retail Buying/Merchandise Buying Systems: Buying System for Staple and Fashion Merchandise – Merchandise Budget Plan – Evaluation of Merchandise Budget Plan – Open–To–Buy System – Allocation of Merchandise to Stores – Analyzing Merchandise Performance – Global Sourcing Decisions – Costs Associated with Global Sourcing – Managerial Issues – Ethical and Legal issues – Counterfeit Merchandise. Retail Marketing Segmentation: Concept, Significance and Philosophies of Market Segmentation – Identification of Target Market – Market Segmentation Process – Understanding Target Market – Market Demand Potential – market Supply Factors – Key Retail Segments

UNIT – V

E–Retailing and Technology in Retailing– Retailing through Internet – Factors Affecting Internet Buying Decisions – Traditional Retailing Vs Cyber Retailing. In Store Technologies, Electronic retailing, Technology. Human Interface, Challenges etc.–: Objectives in HRM in Retailing – Functions – Job Analysis Process – Creating Organizational Structure – Forms of Organization – Setting Up a Retail Organization. Category Management: Definition – Significance – Essentials/Prerequisite of Category Management – Category Management Process – Store layout and Design – Establishing a Pricing Strategy: Concept of Merchandise Pricing – Pricing Options – Setting the Retail Price – Price Objectives – Pricing Strategies – Types of Pricing – Price Adjustments and Discrimination.

Text Books:

1. Retail Management: A Global Perspective –Harjit Singhs. Chand Publishing, ISBN-8121932076.
2. Chetan Bajaj, Rajnish Tuli, Nidhi V Srivastava, ‘Retail Management’, Oxford University Press, ISBN-9780198061151

Reference Books:

1. Barry Berman, Joel Revan ‘Retail management, a strategic approach’ 8th edition, Pearson Education Asia, ISBN-9780273775652,
2. Arif Sheikh, Kaneez Fatima ‘Retail Management’, 4th edition, Himalaya Publishing House, ISBN-978-93-5051-379-8

Web Links:

1. https://onlinecourses.nptel.ac.in/noc22_mg51/preview
2. <https://archive.nptel.ac.in/courses/110/105/110105158/>

Relevant cases have to be discussed in each unit and in examination case study is compulsory from any unit.

CONSUMER BEHAVIOR & CUSTOMER RELATIONSHIP MANAGEMENT

	L	T	P	C
Course Code: 244MS032	3	0	0	3

Course Outcomes:

At the end of the Course, Student will be able to:

- CO1:** Apply research methods to analyze consumer trends in diverse economic and rural settings.
- CO2:** Compare and contrast various consumer behavior models for strategic application.
- CO3:** Examine CRM strategies and their integration with business operations.
- CO4:** Assess CRM implementation frameworks and barriers.
- CO5:** Analyze the role of call centers and multimedia contact centers in CRM operations.

Mapping of Course Outcomes with Program Outcomes:

CO/PO	PO1	PO2	PO3	PO4	PO5	PO6	PO7	PO8
CO1	-	-	-	-	2	-	-	-
CO2	-	-	-	-	2	-	-	-
CO3	-	-	-	-	2	-	-	-
CO4	-	-	-	-	2	-	-	-
CO5	-	-	-	-	2	-	-	-

Mapping of Course Outcomes with Program Specific Outcomes:

CO/PSO	PSO1	PSO2	PSO3
CO1	2	-	-
CO2	2	-	-
CO3	2	-	-
CO4	2	-	-
CO5	2	-	-

UNIT – I

Understanding Consumer Behavior: Defining Consumer Behavior, need for Consumer Behavior, Understanding Consumer through Research Process, Consumer Behavior in a world of economic instability, Rural Consumer Behavior, Consumer Segmentation, Targeting and Positioning, Segmentation & Branding, Rural Markets.

UNIT – II

Environmental Influences on Consumer Behavior: Influence of Culture, Sub Culture, Social Class, Social Group, Family and Personality, Cross-Cultural Consumer Behavior. Consumer Behavior Models: Advert Sheth Model, EKB Model, Howard Sheth Model, Family Decision-making Model, Pavlovian Model and Economic Model

UNIT – III

Customer Relationship Management Fundamentals: Definition and Significance of Customer Relationship Marketing, Theoretical perspectives of relationship, Evolution of Relationship marketing, Stages of relationship, Issues of relationship, Purpose of relationship marketing, Approach towards marketing: A paradigm shift, Historical Perspectives, CRM Definitions, Emergence of CRM practice, CRM cycle, Significance of CRM, CRM Strategy, Customer Life Time Value, Relationship Life Cycle.

UNIT – IV

Building Customer Relationship Management: Requisites for Effective Customer acquisition, Customer Knowledge Management for Effective CRM, Customer Retention Process, Strategies to Prevent Defection and Recover Lapsed Customers, CRM Implementation: CRM framework for Implementation, Implementing CRM process, Integration of CRM with ERP System, Barriers to effective CRM Gartner ‘s Competency model of CRM.

UNIT – V

Functional Components of CRM: Database Management, Database Construction, Data Warehousing, architecture, Data Mining. Characteristics, Data Mining tools and techniques, Meaning, Significance, Advantages, Call Centre, Multimedia Contact Centre, Important CRM software

Text Books:

1. Leon G. Schiffman, Leslie I. Kanuk, S. Ramesh Kumar, 10e, Pearson, ISBN-978-9332555099
2. Alok Kumar, Chabbi Sinha & Rakesh Kumar, Customer Relationship Management: Concepts & Application Biztantra, Delhi, ISBN-9788177226225

Reference Books:

1. David I. Loudon and Albert J. Della Bitta, Consumer behaviour- concepts and applications, TMH, 4e. ISBN-13: 978-0070473812.
2. Zubin Sethna, Jim Blythe, Consumer Behavior, Sage Publications, 4e, 2019, ISBN-13 978-9353885366

Web Links:

1. <https://archive.nptel.ac.in/courses/110/105/110105074/>
2. <https://archive.nptel.ac.in/courses/110/105/110105145/>

Relevant cases have to be discussed in each unit and in examination case study is compulsory from any unit.

MARKETING ANALYTICS

	L	T	P	C
Course Code: 244MS033	2	0	1	3

Course Outcomes:

At the end of the Course, Student will be able to:

- CO1:** Explain the Concepts of Marketing Analytics and their relevance in business
- CO2:** Make use of MS Excel to deal with Marketing Data at basic level
- CO3:** Appreciate Customer's journey through Product Selection Process and Customer Lifetime Value
- CO4:** Develop Analysis in Determining the Pricing Strategies
- CO5:** Analyze the Process of Optimizing Clusters and Measure the Effectiveness of Promotion

Mapping of Course Outcomes with Program Outcomes:

CO/PO	PO1	PO2	PO3	PO4	PO5	PO6	PO7	PO8
CO1	-	2	-	-	-	-	-	-
CO2	-	2	-	-	-	-	-	-
CO3	-	2	-	-	-	-	-	-
CO4	-	2	-	-	-	-	-	-
CO5	-	2	-	-	-	-	-	-

Mapping of Course Outcomes with Program Specific Outcomes:

CO/PSO	PSO1	PSO2	PSO3
CO1	-	2	-
CO2	-	2	-
CO3	-	2	-
CO4	-	2	-
CO5	-	2	-

UNIT – I

Introduction to Marketing Analytics: Definition, Need and Scope of Marketing Analytics, Marketing Analytics Vs Marketing Research, Levels in Marketing Analytics, Adoption and Application of Marketing Analytics, Marketing Analytics and Business Intelligence. MS Excel as a Tool for conduction of Marketing Analytics. Using MS Excel to Organize and Summarize Marketing Data: Creation of Pivot Tables and Organizing Data.

UNIT – II

Summarizing Marketing Data: Summarizing Revenue Data: Month-wise and Product-wise. Slicing & Dicing of Data: Pareto Principle, Report Filters and Slicers. Demographic Analysis: Analyzing Sales Data by Age, Gender, Income and Location, Construction of Crosstabs of Two Demographic Variables. Using GETPIVOT Function for Pulling Data. Adding Data Labels and Data Tables.

UNIT – III

Customer Analytics: Customer Journey Mapping and the Process of Mapping (How to). Metrics for Tracking Customer Experience: Customer Feedback Metrics & Behaviour Derived Customer Metrics. Customer Persona, Building a Customer Persona and its

Benefits, Parts of Buyer Persona. What Customer Wants: Using Conjoint Analysis for Levels in Consumer Decision Process in Product Choices and Product Attributes. Customer Lifetime Value (CLV). Calculating Customer Lifetime Value: Creating the Basic Customer Value Template, Measuring Sensitivity Analysis with Two-Way Tables, Estimating the Chance if Customer is still Active.

UNIT – IV

Pricing Analytics: Pricing, Goals of Pricing, Price Elasticity, Estimating Linear and Power Demand Curves, Using Excel Solver to Optimize Price, Incorporating Complementary Products, Using Solver Table to Price Multiple Products and Finding Demand Curve for All Products. Price Bundling, Bundling Prices to Extract Consumer Surplus, Mixed Bundling, Using Evolutionary Solver to Find Optimal Bundle Prices. Price Skimming.

UNIT – V

Segmentation & Promotion Analytics: Segmentation Analytics-Cluster Analysis and its Applications, Location-wise Clustering, Using Solver to find Optimal Clusters. Using Conjoint Analysis to Segment a Market, Using Decision Trees for Segmenting the Market. Promotion Analytics: Promotions and Types of Promotions, Discounting & Types of Discounting. Measuring the Effectiveness of Advertising: The Adstock Model. Media Selection Models: Linear Media Allocation Model, Quantity Discounts, Monte Carlo Media Allocation Simulation. Pay per Click Advertising.

Text Books:

1. Seema Gupta & Avadhoot Jathar, Marketing Analytics, Wiley, 2021, ISBN-09354242626
2. Wayne L. Winston, Marketing Analytics: Data Driven Techniques with Microsoft Excel, ISBN-978-1118373439

Reference Books:

1. Mike Grigsby, Marketing Analytics, Kogan Page, ISBN-9781398608191.
2. Robert Kozielski, Measuring Marketing Analytics, Emerald Publishing ASIN: B074DTP4K

Web Links:

1. https://onlinecourses.nptel.ac.in/noc20_mg30/preview
2. <https://archive.nptel.ac.in/courses/110/105/110105142/>

Relevant cases have to be discussed in each unit and in examination case study is compulsory from any unit.

STRATEGIC MARKETING MANAGEMENT

Course Code: 244MS034	L	T	P	C
	3	0	0	3

Course Outcomes:

At the end of the Course, Student will be able to:

- CO1:** Explain the concepts of vision, mission, objectives, and goals in relation to marketing strategies
- CO2:** Estimate the need for and forms of corporate restructuring.
- CO3:** Interpret marketing strategies across FMCG, industrial, and services sectors, and analyze constraints in effective marketing strategy implementation.
- CO4:** Develop marketing audits to assess strategic effectiveness and measure marketing performance.
- CO5:** Determine the growing importance of public-private partnerships, and assess strategies linking CSR with profitability and sustainability

Mapping of Course Outcomes with Program Outcomes:

CO/PO	PO1	PO2	PO3	PO4	PO5	PO6	PO7	PO8
CO1	-	-	-	2	-	-	-	-
CO2	-	-	-	2	-	-	-	-
CO3	-	-	-	2	-	-	-	-
CO4	-	-	-	2	-	-	-	-
CO5	-	-	-	2	-	-	-	-

Mapping of Course Outcomes with Program Specific Outcomes:

CO/PSO	PSO1	PSO2	PSO3
CO1	2	-	-
CO2	2	-	-
CO3	2	-	-
CO4	2	-	-
CO5	2	-	-

UNIT – I

Introduction to Strategic Marketing Management: Strategic marketing process. Concept of strategic marketing. Levels of Strategies-Corporate, Business and Operational level. Strategy Formulation – Vision, Mission, Objectives and Goals of business and their relationship with Strategic Marketing Management. Considerations for formulation of marketing strategies for all components of Product, Price, Promotion and Distribution.

UNIT – II

Corporate Restructuring and Strategy Evaluation: Introduction to corporate restructuring, need for corporate restructuring and its forms. Evaluation of strategic alternatives, types of strategic alternatives like portfolio analysis and its techniques. Model as basic foundation of Strategic Marketing - McKinsey's 7s framework for analyzing and improving organizational effectiveness.

UNIT – III

Marketing Strategy Implementation: Integration of Marketing Strategies and their application to different business sectors – FMCG, Industrial, & Services. Constraints in marketing strategy implementation.

UNIT – IV

Marketing Strategy Evaluation: Marketing Audits & their scope – Measurement of Marketing Performance and its feedback to next year 's Marketing strategy formulation. Economic losses due to disasters-Issues and Strategies for preventing disasters and preparedness measures.

UNIT – V

Recent Trends in Strategic Marketing Management - Eco-friendly strategies. Growing need of public private partnership. Corporate Social Responsibility (CSR), strategies of linking CSR with profit and sustainability.

Text Books:

1. Thompson/Strickland, Strategic Management: Concepts and Cases, McGrawHill Companies; 11th edition, ISBN-9780073037141
2. David Hunger and Thomas L. Wheelen "Strategic Management" Addison Wesley; 6 Sub edition, ISBN-9781292034157

Reference Books:

1. William F. Glueck, Business Policy and Strategic Management, McGraw-Hill, ISBN - 9780070235311
2. Azhar Kazmi, Strategic Management and Business Policy, Third Edition, ISBN-9780070263628

Web Links:

1. <https://archive.nptel.ac.in/courses/110/104/110104055/>
2. <https://nptel.ac.in/courses/110104055>

Relevant cases have to be discussed in each unit and in examination case study is compulsory from any unit.

DIGITAL & SOCIAL MEDIA MARKETING

	L	T	P	C
Course Code: 244MS035	3	0	0	3

Course Outcomes:

At the end of the Course, Student will be able to:

- CO1:** Explain the concept, scope, and benefits of digital marketing and compare digital marketing with traditional marketing
- CO2:** Compare various digital marketing channels including website marketing, search engine marketing, social media marketing, and mobile marketing
- CO3:** Develop a digital marketing plan including situational analysis, goals, objectives, marketing strategy, action plan, and budget
- CO4:** Analyze the importance of SEM and online advertising and compare payment methods in online advertising.
- CO5:** Assess the role of social media platforms like Facebook, LinkedIn, and Twitter in customer reach and retention.

Mapping of Course Outcomes with Program Outcomes:

CO/PO	PO1	PO2	PO3	PO4	PO5	PO6	PO7	PO8
CO1	-	-	-	2	-	-	-	-
CO2	-	-	-	2	-	-	-	-
CO3	-	-	-	2	-	-	-	-
CO4	-	-	-	2	-	-	-	-
CO5	-	-	-	2	-	-	-	-

Mapping of Course Outcomes with Program Specific Outcomes:

CO/PSO	PSO1	PSO2	PSO3
CO1	2	-	-
CO2	2	-	-
CO3	2	-	-
CO4	2	-	-
CO5	2	-	-

UNIT – I

Understanding Digital Marketing: Concept, Need and Scope of Digital Marketing, Comparison of Marketing and Digital Marketing, Components of Digital Marketing, Benefits of Digital Marketing, Digital Marketing Platforms and Strategies, Digital Marketing Trends.

UNIT – II

Channels of Digital Marketing: Digital Marketing: Website Marketing, Search Engine Marketing, Online Advertising, Email Marketing, Blog Marketing, Social Media Marketing, Audio, Video and Interactive Marketing, Online Public Relations, Mobile Marketing, Migrating from Traditional Channels to Digital Channels. Marketing in the Digital Era: Segmentation: Importance of Audience Segmentation, Use of Digital Media by different Segments. Organizational Characteristics, Purchasing Characteristics, Using Digital Media for Reach, Acquisition and Retention of New Customers, Digital Media for Customer Loyalty.

UNIT – III

Digital Marketing Plan: Need of a Digital Marketing Plan, Elements of a Digital Marketing Plan: Marketing Plan, Executive Summary, Mission, Situational Analysis. Opportunities and Issues, Goals and Objectives, Marketing Strategy, Action Plan, Budget, Writing the Marketing Plan and Implementing the Plan.

UNIT – IV

Search Engine Marketing (SEM) and Online Advertising: Importance of SEM, Understanding Web Search: Key Words, HTML Tags, Inbound Links. Online Advertising vs. Traditional Advertising. Payment Methods of Online Advertising: CPM (Cost-per-Thousand) and CPC (Cost-per click). Display of Ads: Choosing a Display Ad Format, Landing Page and its Importance.

UNIT – V

Social Media Marketing: Understanding social media, Social Networking with Face book, LinkedIn, Blogging as a Social Medium, Micro blogging with Twitter, Social Sharing with YouTube and social media for Customer Reach, Acquisition and Retention. Measurement of Digital Media: Analyzing Digital Media Performance, Analyzing Website Performance, Analyzing Advertising Performance.

Text Books:

1. Dinesh Kumar, Marketing in the Digital Age, Sage Publications, 2021, ISBN-9789353887681.
2. Annmarie Hanlon, Digital Marketing: Strategic Planning & Integration, Sage Publications, 1e, 2019, ISBN-9781526426666, 1526426668.

Reference Books:

1. Chuck Hemann & Ken Burbary, Digital Marketing Analytics, Pearson, 2e, ISBN-9780134998657, 0134998650.
2. Judy Strauss & Raymond Frost, E-Marketing, Pearson, ISBN-9781292000428, 1292000422.

Web Links:

1. https://onlinecourses.nptel.ac.in/noc22_mg109/preview
2. https://onlinecourses.swayam2.ac.in/ugc19_hs26/preview

Relevant cases have to be discussed in each unit and in examination case study is compulsory from any unit.

SERVICES MARKETING

Course Code: 244MS036	L	T	P	C
	3	0	0	3

Course Outcomes:

At the end of the Course, Student will be able to:

- CO1:** Explain the concepts of services and service marketing.
- CO2:** Identify and explain the key characteristics of services and differentiate the Segmentation, Targeting, Positioning process in services.
- CO3:** Estimate service quality management using models like SERVQUAL and the gap model
- CO4:** Analyze strategies to address the challenges of intangibility, inconsistency, and inseparability of services.
- CO5:** Assess current trends and innovations in services marketing including e-commerce, e-CRM, self-service technologies, and marketing strategies for diverse service categories.

Mapping of Course Outcomes with Program Outcomes:

CO/PO	PO1	PO2	PO3	PO4	PO5	PO6	PO7	PO8
CO1	-	-	-	2	-	-	-	-
CO2	-	-	-	2	-	-	-	-
CO3	-	-	-	2	-	-	-	-
CO4	-	-	-	2	-	-	-	-
CO5	-	-	-	2	-	-	-	-

Mapping of Course Outcomes with Program Specific Outcomes:

CO/PSO	PSO1	PSO2	PSO3
CO1	2	-	-
CO2	2	-	-
CO3	2	-	-
CO4	2	-	-
CO5	2	-	-

UNIT – I

Understanding Services: Introduction - meaning of service concepts, nature and scope of services, marketing of services versus physical goods, growth of services sector in India, Classification of services. Customer involvement in service process and managing service encounters

UNIT – II

Services Marketing: The distinguishing key characteristics of services, Consumer behaviour in services. Services marketing mix - Product, Pricing, Place, Promotion, People, Physical Evidence and Process. - Service triangle - Segmenting, Targeting and positioning for services marketing.

UNIT – III

Role of Quality in Service – Service Quality management, Dimensions of service quality, – gap model - SERVQUAL – demand management services strategies– service blue printing - Service failures and Recovery strategies, etc.

UNIT – IV

Overview of Strategies for Services marketing - strategies to deal with intangibility, inventory inconsistency and inseparability of Services - basic service package – new service development stages. Pricing objectives and strategies – service distribution

UNIT – V

Contemporary Issues in Service Marketing - Current trends in services marketing. Ecommerce and e-marketing – e-CRM - Innovations in services marketing- self-service technologies - Marketing of varied services.

Text Books:

1. Zeithmal, v. A., Bitner, M. J., Gremler, D. D., & Pandit, A, Service Marketing: Integrating Customer Focus Across the Firm, 7TH Edition, McGraw Hill Education, ISBN-9780078112102, 0078112109.
2. Chistopher lovelock, Services Marketing, 8th Edition, Pearson Education, ISBN-9780134613772, 0134613775.

Reference Books:

1. Shankar, R. Services Marketing: The Indian Perspective, Excel, ISBN-9788174462671, 8174462678.
2. Joachen Wirtz, Patricia Chew and Christopler Lovelock, Essentials of Services Marketing, 2nd Edition, Pearson Education, ISBN-9781292090061.

Web Links:

1. <https://archive.nptel.ac.in/courses/110/105/110105078/>
2. https://onlinecourses.nptel.ac.in/noc20_mg12/preview

Relevant cases have to be discussed in each unit and in examination case study is compulsory from any unit.

MARKETING RESEARCH

Course Code: 244MS037	L	T	P	C
	3	0	0	3

Course Outcomes:

At the end of the Course, Student will be able to:

- CO1:** Explain the entry and editing of marketing research data.
- CO2:** Develop the marketing research design and develop a marketing research proposal
- CO3:** Identify the sample design for the marketing research.
- CO4:** Examine the measurement scales and questionnaire design.
- CO5:** Analyze hypothesis testing and data presentation.

Mapping of Course Outcomes with Program Outcomes:

CO/PO	PO1	PO2	PO3	PO4	PO5	PO6	PO7	PO8
CO1	-	2	-	-	-	-	-	-
CO2	-	2	-	-	-	-	-	-
CO3	-	2	-	-	-	-	-	-
CO4	-	2	-	-	-	-	-	-
CO5	-	2	-	-	-	-	-	-

Mapping of Course Outcomes with Program Specific Outcomes:

CO/PSO	PSO1	PSO2	PSO3
CO1	2	-	-
CO2	2	-	-
CO3	2	-	-
CO4	2	-	-
CO5	2	-	-

UNIT – I

Introducing Spreadsheet: Choosing the correct tool; Creating and Saving; Spreadsheet workspace; Managing the workspace; Entering and editing data; Data entry; Selecting cells; Saving time when entering data. Presenting a spreadsheet; Number and date/time format tools; Percentages; Dates and Times; Currency; Text; Performing calculations; Basic arithmetic; Using functions; Replicating formulae; Absolute cell addressing; References between worksheets.

UNIT – II

Marketing Research Design: The Process of Defining the Problem and Developing an Approach, Defining a Marketing Research Problem, Exploratory, Descriptive, Casual Research Design and Marketing Research Proposal.

UNIT – III

Sampling and Data Collection: Sampling Design Process, Classification of Sampling Techniques, Probability and Non-Probability Sampling Techniques, Internet Sampling, Sampling Distribution, Sample Size Determination, Non-Response Issues in Sampling. Sources of Data Collection, Methods of Data Collection.

UNIT – IV

Measurement and Scaling: Concept of Measurement, Types of Measurement Scales: Likert, Semantic Differential, Guttman, Interval, Q-Sort, Nature of Measurement, Characteristics of a Good Measurement, Nature of Attitude Scale, Rating Scale, Ranking Scale, Questionnaire Design, Editing, Coding and Tabulation of data.

UNIT – V

Analysis and Presentation of Data: Data Preparation, Data Preparation Process, Statistically Adjusting Data, Frequency Distribution, Cross Tabulation, Hypothesis Testing, Bi-Variate Analysis, Correlation, Regression, Multi-Variate Analysis, Discriminant, Logit Analysis, Factor Analysis, Cluster Analysis. Report Writing, Report Preparation and Presentation.

Text Books:

1. Naresh Malhotra, Satyabhushan Dash, Marketing Research, Pearson, 7e, 2019, ISBN-9781292265636, 1292265639.
2. GC Beri, Marketing Research, 4e, McGraw Hill, ISBN-9780074604045, 007460404X.

Reference Books:

1. Donald R Cooper, Pamela S Schindler, Marketing Research Concepts and Cases, McGraw Hill, ISBN-9780071115711, 0071115714.
2. David J Luck, Ronald S Rubin, Marketing Research, 9e, PHI, ISBN-9780135578285, 0135578280.

Web Links:

1. <https://archive.nptel.ac.in/courses/110/107/110107080/>
2. https://onlinecourses.nptel.ac.in/noc20_mg49/preview

Relevant cases have to be discussed in each unit and in examination case study is compulsory from any unit.

BRAND MANAGEMENT

Course Code: 244MS038	L	T	P	C
	3	0	0	3

Course Outcomes:

At the end of the Course, Student will be able to:

- CO1:** Explain the basic concepts of branding,
- CO2:** Analyze brand-related terms and brand positioning
- CO3:** Build brand equity through strategic marketing, brand value, planning, and potential.
- CO4:** Develop and manage brand portfolios, architecture models, and addressing challenges.
- CO5:** Identify extensions' pros and cons, leveraging various secondary brand associations effectively.

Mapping of Course Outcomes with Program Outcomes:

CO/PO	PO1	PO2	PO3	PO4	PO5	PO6	PO7	PO8
CO1	2	-	-	-	-	-	-	-
CO2	2	-	-	-	-	-	-	-
CO3	2	-	-	-	-	-	-	-
CO4	2	-	-	-	-	-	-	-
CO5	2	-	-	-	-	-	-	-

Mapping of Course Outcomes with Program Specific Outcomes:

CO/PSO	PSO1	PSO2	PSO3
CO1	2	-	-
CO2	2	-	-
CO3	2	-	-
CO4	2	-	-
CO5	2	-	-

UNIT – I

Branding Concepts: Introduction to Brand, Brand and Branding Basics, Relationship of Brands with Customers, Building Successful Brands. Benefits of branding, Inputs for branding, Model (David Aker's) to develop brand strategy, Brand management process.

UNIT – II

Terms Associated with Brands: Understanding Various Terms, Brand Names and Brand Extensions, Co-Branding and Corporate Branding, Brand Associations and Brand Image. Brand Positioning: Definition and importance of positioning. Positioning Strategy: Target market, defining competition, updating positioning overtime.

UNIT – III

Brand Equity: Meaning, Relevance of brand equity to business, Brand elements to build brand equity. Designing marketing programme (Product, Price, Distribution channel and IMC strategy) to build brand equity. Brand Processing Brand Evolution: Value of Brand, Brand Planning and Brand Potential.

UNIT – IV

Brand Portfolio: Meaning and Objectives of portfolio, Developing portfolio, Challenges in brand portfolio management. Brand Architecture: Models of brand architecture, Developing brand architecture, Indicators of brand architecture issues.

UNIT – V

Product and Brand Extensions: Advantages of Extensions, Disadvantages of Brand Extensions, Brand Extension Guidelines. Leveraging Secondary Brand Associations: Company, Country of origin, Channels of Distribution, Co-Branding, Licensing, Celebrity Endorsement and Events.

Text Books:

1. Strategic Brand Management, 4th Edition. Kevin Lane Keller, Pearson, ISBN-9780132664257, 0132664259.
2. Kirti Dutta, Brand Management –Principles and Practices, Oxford Higher Education, New Delhi, ISBN-9780198069867, 0198069863.

Reference Books:

1. Philip Kotler, Kevin Lane Keller, Abraham Koshy and Mithileshwar Jha, "Marketing Management", Pearson 14th Edition New Delhi, ISBN-9781292089652, 1292089652
2. Brand Management: Principles and Practices, Kriti dutt, Pearson, ISBN-9780198069867

Web Links:

1. https://onlinecourses.nptel.ac.in/noc23_mg117/preview
2. <https://archive.nptel.ac.in/courses/110/107/110107161/>

Relevant cases have to be discussed in each unit and in examination case study is compulsory from any unit.

PERFORMANCE MANAGEMENT

	L	T	P	C
Course Code: 244MS039	3	0	0	3

Course Outcomes:

At the end of the Course, Student will be able to

- CO1:** Explain the key concepts of Performance Management.
- CO2:** Identify the process of Performance Management by comparing with Human Resource Management.
- CO3:** Examine the planning and process of Performance Analysis.
- CO4:** Develop the process of Performance Review Discussions and Ratings.
- CO5:** Implement Performance Management System to selected Organizations.

Mapping of Course Outcomes with Program Outcomes:

CO/PO	PO1	PO2	PO3	PO4	PO5	PO6	PO7	PO8
CO1	-	-	-	-	2	-	-	-
CO2	-	-	-	-	2	-	-	-
CO3	-	-	-	-	2	-	-	-
CO4	-	-	-	-	2	-	-	-
CO5	-	-	-	-	2	-	-	-

Mapping of Course Outcomes with Program Specific Outcomes:

CO/PSO	PSO1	PSO2	PSO3
CO1	2	-	-
CO2	2	-	-
CO3	2	-	-
CO4	2	-	-
CO5	2	-	-

UNIT – I

Introduction to Performance Management: Definition of Performance Management, Evolution of Performance Management, Definitions and Differentiation of Terms Related to Performance Management. Role, Importance and Dimensions of Performance Management in organization. Linkage of Performance Management to Other HR Processes, Performance Management in today scenario.

UNIT – II

Performance Management Process: Relevance of objectives in organizations and Performance Management, organizational and Individual performance in Performance Management, process of Performance Management, Performance Management and Human Resource Management.

UNIT – III

Performance Planning and Analysis: Concept of Performance Planning, Performance Planning and Performance Analysis, KPAs and Performance Planning, Components of Performance Planning. Objectives of Performance Analysis, Performance Analysis Process.

UNIT – IV

Performance Review and Discussion: Significance of Performance Review in Performance Management, Process of Performance Review, Performance Ratings: Factors affecting appraisals, Methods and Errors, Reducing Rater Biases. Performance Review Discussions: Objectives, Requisites, Process, Role of Mentoring and Coaching in Performance Review Discussions.

UNIT – V

Implementing Performance Management System: Operationalizing change through Performance Management Process, Factors affecting Implementation, Pitfalls of Implementation, Experiences in Performance Management: Traditional Practices in the Industry, Recent approaches in practice, Case studies of Performance Management Systems in selected organizations

Text Books:

1. Rao, T.V., “Performance Management and Appraisal Systems – HR Tools for Global competitiveness” Response Books, New Delhi, ISBN-9780761998471, 0761998470
2. Herman Aguinis, “Performance Management”, Pearson Education, 2nd edition, ISBN-9781292037134, 129203713X

Reference Books:

1. Kohli A S and Deb T, “Performance Management”, Oxford University Press, ISBN-9780195693379, 019569337X
2. Chadha Prem, “Performance Management – It’s about Performing – Not just Appraising”, Macmillan India Limited, New Delhi, ISBN- 9780333937969, 0333937961

Web Links:

1. <https://archive.nptel.ac.in/courses/110/105/110105137/>
2. <http://digimat.in/nptel/courses/video/110105137/L03.html>

Relevant cases have to be discussed in each unit and in examination case study is compulsory from any unit.

INTERNATIONAL HUMAN RESOURCE MANAGEMENT

Course Code: 244MS040	L	T	P	C
	3	0	0	3

Course Outcomes:

At the end of the Course, Student will be able to:

- CO1:** Explain the concepts of International HRM by comparing with Domestic HRM.
- CO2:** Identify and manage various assignments in international context.
- CO3:** Demonstrate Cross Culture Communication and Negotiation
- CO4:** Analyze different Approaches of Compensation in Global Assignments
- CO5:** Apply the IHRD concepts through Global strategic advancements.

Mapping of Course Outcomes with Program Outcomes:

CO/ PO	PO1	PO2	PO3	PO4	PO5	PO6	PO7	PO8
CO1	2	-	-	2	-	-	-	-
CO2	2	-	-	2	-	-	-	-
CO3	2	-	-	2	-	-	-	-
CO4	2	2	-	2	-	-	-	-
CO5	2	-	2	2	-	-	-	-

Mapping of Course Outcomes with Program Specific Outcomes:

CO/P SO	PSO1	PSO2	PSO3
CO1	2	-	2
CO2	2	2	2
CO3	2	2	2
CO4	2	2	2
CO5	2	2	2

UNIT – I

Introduction: A Global HR Perspective in New Economy-Challenges of Globalization - Implications of Managing People and Leveraging Human Resource - Strategic Role of International HRM – Distinction between Domestic and International HRM – HR Challenges at International Level.

UNIT – II

Managing International Assignments: Significance -Global HR Planning – Staffing policy – Training and development – performance appraisal –International Labour relations – Industrial democracy - Positioning Expatriate – Repatriate – factors of consideration - Strategies - Legal content of Global HRM- International assignments for Women - Problems.

UNIT – III

Cross Culture Management: Importance – Concepts and issues – theories, considerations - Problems – Skill building methods – Cross Culture Communication and Negotiation – Cross Culture Teams. Talent crunch – Indian MNCs and Challenges.

UNIT – IV

Compensation Management: Objectives -Importance – Concepts- Trends - Issues – Methods – Factors of Consideration – Models – incentive methods – Approaches of Compensation in Global Assignments - global compensation implications on Indian systems - Performance Management.

UNIT – V

Global Strategic Advantages Through HRD: Measures for creating global HRD Climate – Strategic Framework of HRD and Challenges - Globalization and Quality of Working Life and Productivity – Challenges in Creation of New Jobs through Globalization, New Corporate Culture.

Text Books:

1. Subba Rao P: —International Human Resource Management, Himalaya Publishing House, Hyderabad. ISBN- 978-93-5596-431-1
2. Nilanjan Sen Gupta: —International Human Resource Management Text and cases, Excel Books, New Delhi, ISBN-9788174465191, 8174465197

Reference Books:

1. Aswathappa K, Sadhana Dash: —International Human Resource Management, TMH, New Delhi, ISBN-9355325312 · 9789355325310
2. Monir H Tayeb: —International Human Resource Management, Oxford Universities Press, Hyderabad, ISBN-978-0199277278.

Web Links:

1. <https://www.youtube.com/watch?v=7ea810vM0OU>
2. <https://www.youtube.com/watch?v=bxkgpfh58rU>

Relevant cases have to be discussed in each unit and in examination case study is compulsory from any unit.

HR ANALYTICS

Course Code: 244MS041	L	T	P	C
	2	0	1	3

Course Outcomes:

At the end of the Course, Student will be able to:

- CO1:** Gain an understanding of the relevance of HR Analytics in the current scenario.
- CO2:** Develop an understanding of the models of conducting HR Analytics
- CO3:** Use MS Excel for conduction of HR Analytics for key HR Processes
- CO4:** Compare various tools and software technologies used for conduction of descriptive HR Analytics and Visualization of HR Data.
- CO5:** Appreciate the significance of Predictive and Prescriptive Analytics.

Mapping of Course Outcomes with Program Outcomes:

CO/PO	PO1	PO2	PO3	PO4	PO5	PO6	PO7	PO8
CO1	2	2	-	-	-	-	2	-
CO2	2	2	-	-	-	-	2	-
CO3	2	2	-	-	-	-	2	-
CO4	2	2	-	-	-	-	2	-
CO5	2	2	-	-	-	-	2	-

Mapping of Course Outcomes with Program Specific Outcomes:

CO/PSO	PSO1	PSO2	PSO3
CO1	2	2	2
CO2	2	2	2
CO3	2	2	2
CO4	2	2	2
CO5	2	2	2

UNIT – I

Introduction to HR Analytics: History of Different HRM Perspectives, Transition from HRM to HCM and Gaining Sustainable Advantage through HCM. HR Analytics and Changing Role of HR Professionals. Importance, Scope and Benefits of HR Analytics. Levels of Analysis and Conducting analytics. Key Influencers of HR Analytics Process. Big Data Era in HR Analytics, HR Analytics – Linkage to Business Outcomes.

UNIT – II

Understanding HR Analytics: Conducting HR Analytics: Models of HR Analytics, How to Conduct HR Analytics. Understanding HR Data: Importance of Data, Types and Scales of Data, Methods of Capturing Data, Data Examination & Purification. Understanding various HR Metrics from the perspective of HR Analytics.

UNIT – III

Analytics for Key HR Processes Using MS Excel: HR Analytics for Recruitment & Selection, Training & Development, Performance Appraisal, Talent Management, Employee Engagement, Compensation Management and Expatriate Management.

UNIT – IV

Descriptive Analytics: Overview of Select Tools for Conduction HR Analytics: MS Excel, R, Tableau, Power BI, Python, SPSS & PSPP. Descriptive Analytics in HR: HR Dashboards using MS Excel, Slicing and Dicing of HR Data using MS Excel Pivot Table Applications, Data Visualization for Key HR processes.

UNIT – V

Predictive & Prescriptive HR Analytics: Predictive HR Analytics: Correlation, Linear and Multiple Regression, Factor Analysis and Cluster Analysis, Comparison of Means and Analysis of Variance for Manpower Demographics, Employee Satisfaction, And Training Effectiveness etc. Prescriptive HR Analytics, Predictive vs Prescriptive HR Analytics, Future of HR Analytics.

Text Books:

1. Rama Shankar Yadav & Sunil Maheshwari, HR Analytics, Wiley, 2021, ISBN-9390421551.
2. Pratyush Banerjee, Jatin Pandey & Manish Gupta, HR Analytics: Practical Applications of HR Analytics, Sage, 2019, ISBN-978-9353282967.

Reference Books:

1. Nishant Uppal, Human Resource Analytics, Pearson, 2021, ISBN-9390168406.
2. Bharti Motwani, HR Analytics: Practical Approach Using Python, Wiley, 2021, ISBN-978-9354240027.

Web Links:

1. https://onlinecourses.nptel.ac.in/noc24_hs126/preview
2. <https://www.coursera.org/learn/human-resources-analytics>

Relevant cases have to be discussed in each unit and in examination case study is compulsory from any unit.

ORGANIZATION CHANGE AND DEVELOPMENT

	L	T	P	C
Course Code: 244MS042	3	0	0	3

Course Outcomes:

At the end of the Course, Student will be able to:

- CO1:** Explain the concepts, types, and models of organizational change.
- CO2:** Identify reasons for resistance to change.
- CO3:** Explain the history, process, and key components of OD.
- CO4:** Develop appropriate intervention strategies for specific organizational contexts.
- CO5:** Analyze different perspectives and concepts of learning organizations, knowledge management, and work culture.

Mapping of Course Outcomes with Program Outcomes:

CO/PO	PO1	PO2	PO3	PO4	PO5	PO6	PO7	PO8
CO1	-	-	-	-	2	-	-	-
CO2	-	-	-	-	2	-	-	-
CO3	-	-	-	-	2	-	-	-
CO4	-	-	-	-	2	-	-	-
CO5	-	-	-	-	2	-	-	-

Mapping of Course Outcomes with Program Specific Outcomes:

CO/PSO	PSO1	PSO2	PSO3
CO1	2	-	-
CO2	2	-	-
CO3	2	-	-
CO4	2	-	-
CO5	2	-	-

UNIT – I

Organizational Change: Introduction, Meaning, Nature and Types of Change, Models of Change - Lewis’s Force field, Systems Model, Action research model, organizational vision and strategic planning, Dynamics of planned change, Change and its Impact.

UNIT – II

Resistance to Change: Reasons for the resistance, overcoming resistance for the change, Systematic approach to make change, Factors for effective change, Strategies and Skills of leaders for Communicating Change, Designing the change, Implementing Change, Consolidating Change.

UNIT – III

Organization Development (OD): Introduction to Organization Development, History of OD, evolution of OD, Process of OD, Challenges to OD, entering into OD relationship, developing a contract, **Diagnosing Organizations**, Diagnostic Strategies and Skills, Power, Politics and Ethics in OD, Evaluating change and future of Organizational Development, OD Change Agents.

UNIT – IV

Organization Development Interventions: Definition, Types and Process of OD Intervention, Results of OD, Actors to be considered, Choosing and sequencing intervention activities, Typology of interventions based on target groups, Human Process interventions, Structural and Miscellaneous OD Interventions, IT and OD, TQM and OD, Organizational Creativity, OD in International Context.

UNIT – V

Perspectives of Organisation Development: Learning Organisation, Knowledge Management and OD, Organisational Design and Work Culture, Organisational Restructuring.

Text Books:

1. Nilanjan Sengupta: Managing Changing Organisations, PHI Learning, New Delhi, ISBN-8120329651, 9788120329652.
2. Adrian Thornhill: Managing Change, Pearson Education, New Delhi. Radha R Sharma: Change Management, TMH, New Delhi, ISBN-9780070635869, 0070635862.

Reference Books:

1. Cummings: “Theory of Organisation Development and Change”, Cengage Learning, New Delhi, 9788131502877
2. Robert A Paton: Change Management, Sage Publications, New Delhi, ISBN-9788178299235, 8178299232.

Web Links:

1. <https://archive.nptel.ac.in/courses/110/101/110101146/>
2. <https://archive.nptel.ac.in/courses/110/101/110101146/>

Relevant cases have to be discussed in each unit and in examination case study is compulsory from any unit.

CONTEMPORARY PRACTICES IN HR

Course Code: 244MS043	L	T	P	C
	3	0	0	3

Course Outcomes:

At the end of the Course, Student will be able to:

- CO1:** Explain Contemporary trends towards a new HR
- CO2:** Develop knowledge on regulations and public policy influenced by social trends, change management and people's completion in labor market.
- CO3:** Identify HR expectations and help to enhance their knowledge and engagement
- CO4:** Determine the management of international workforce and build knowledge on how to opt ethical decision and strategies.
- CO5:** Examine various functions to evaluate and manage Human Resources.

Mapping of Course Outcomes with Program Outcomes:

CO/PO	PO1	PO2	PO3	PO4	PO5	PO6	PO7	PO8
CO1	-	-	-	2	-	-	-	-
CO2	-	-	-	2	-	-	-	-
CO3	-	-	-	2	-	-	-	-
CO4	-	-	-	2	-	-	-	-
CO5	-	-	-	2	-	-	-	-

Mapping of Course Outcomes with Program Specific Outcomes:

CO/PSO	PSO1	PSO2	PSO3
CO1	2	-	-
CO2	2	-	-
CO3	2	-	-
CO4	2	-	-
CO5	2	-	-

UNIT – I

Introduction: Contemporary trends towards a new HR, Future agendas, Competition and choice– Introduction, Competitive intensity, Financialization, The impact of increased competitive intensity. People and skills - Demand for people, Supply of people, Demand for skills, Supply of skills, The hourglass metaphor.

UNIT – II

Regulation and Public Policy- A regulatory revolution, Contemporary debates, Likely future developments, The wider public policy agenda. Social trends- Affluence and inequality, Individualism, Ethical awareness. Flexibility and change-Change management, Managing the consequences of change, Flexible working. Competing for people-Reward, Employer branding, Labor market segmentation.

UNIT – III

Managing Expectations -Hopes and expectations, Expectancy theory, Equity theory, psychological contracts, managing expectations in practice, are expectations changing. Engaging people- Defining engagement, Current interest in engagement, Benefits for employees, Benefits for employers, improving levels of employee engagement, Criticisms of employee engagement initiatives, Line management Managing; knowledge and learning-Human capital, Knowledge management, learning organizations, Managing knowledge workers

UNIT – IV

Managing an International Workforce: Convergence and divergence, Cultural differences, Institutional differences, Expatriates, culturally diverse teams, Structural issues. Managing ethically - Ethical decision-making in HRM, theory, Ethical decision-making in HRM, practice, Equality and diversity. Developing HR Strategies- Alternative conceptions of HR strategy, Contingency models, Positioning an organization in the labor market, Contemporary approaches to human resource planning.

UNIT – V

Managing the HR Function-Adding value, Outsourcing, Ulrich's models Evaluating the HR contribution, Evaluation criteria, Evaluation methods and Cutting-edge approaches to evaluation.

Text Books:

1. Contemporary Issues in Human Resource Management By: Stephen Taylor, Publisher: Chartered Institute of Personnel and Development, ISBN-9781843980582, 9781843980582.
2. Contemporary Human Resource Management Text and Cases, sixth edition, Sage publications, ISBN-9781529758276.

Reference Books:

1. People Resourcing: Contemporary HRM in Practice: 3rd Paperback by Stephen Pilbeam (Author), Marjorie Corbridge (Author), ISBN-978-0273703792
2. Contemporary Human Resource Practices by Arthy Infanta A, ISBN-979-8887498232

Web Links:

1. <https://srmuniv.digimat.in/nptel/courses/video/122105020/L22.html>
2. <https://www.youtube.com/watch?v=E5mvG6jrDjo>

Relevant cases have to be discussed in each unit and in examination case study is compulsory from any unit.

INDUSTRIAL RELATIONS

Course Code: 244MS044	L	T	P	C
	3	0	0	3

Course Outcomes:

At the end of the Course, Student will be able to:

- CO1:** Explain the concept and background of industrial relations in India.
- CO2:** Identify the growth, objectives, and legal framework of trade unions in India.
- CO3:** Analyze the concept and levels of workers' participation in management.
- CO4:** Assess the provisions of the Workmen Compensation Act and Employees' State Insurance Act concerning social security.
- CO5:** Discover the causes of employee grievances

Mapping of Course Outcomes with Program Outcomes:

CO/PO	PO1	PO2	PO3	PO4	PO5	PO6	PO7	PO8
CO1	-	-	-	2	-	-	-	-
CO2	-	-	-	2	-	-	-	-
CO3	-	-	-	2	-	-	-	-
CO4	-	-	-	2	-	-	-	-
CO5	-	-	-	2	-	-	-	-

Mapping of Course Outcomes with Program Specific Outcomes:

CO/PSO	PSO1	PSO2	PSO3
CO1	2	-	-
CO2	2	-	-
CO3	2	-	-
CO4	2	-	-
CO5	2	-	-

UNIT – I

Industrial Relations Management: Concept- Evaluation –Background of industrial Relations in India- Influencing factors of IR in enterprise and the consequences. Economic, Social and Political environments- Employment Structure –Social Partnership-Wider approaches to industrial relations- Labor Market.

UNIT – II

Trade Unions: Introduction-Definition and objectives-growth of Trade Unions in India-trade Unions Act, 1926 and Legal framework-Union recognition-Union Problems-Employees Association-introduction, Objective Membership, Financial Status.

UNIT – III

Quality of Work Life: Workers' Participation in Management - Worker's Participation in India, shop floor, Plant Level, Board Level- Workers' Welfare in Indian scenario- Collective bargaining concepts & Characteristics –Promoting peace. Wage and Salary administration: Nature & Significance of wage, salary administration, essentials- Minimum wage- Fair wage, Real wage, Incentives & fringe benefits. Issues and Constraints in Wage Determination in India.

UNIT – IV

Social Security: Introduction and types –Social Security in India, Health and Occupational safety programs- Salient features of Workmen Compensation Act and Employees’ State Insurance Act relating to social security – Workers’ education objectives -Rewarding.

UNIT – V

Employee Grievances: Causes of Grievances –Conciliation, Arbitration and Adjudication procedural aspects for Settlement of Grievances –Standing Orders- Code Discipline. Industrial Disputes: Meaning, nature and scope of industrial disputes - Cases and Consequences of Industrial Disputes –Prevention and Settlement of industrial disputes in India.

Text Books:

1. Mamoria: “Dynamics of Industrial Relations”, Himalaya Publishing House, New Delhi, ISBN-9352621697.
2. B.D. Singh: “Industrial Relations” Excel Books, New Delhi. ISBN: 9788174466204

Reference Books:

1. ArunMonappa: “Industrial Relations”, TMH, New Delhi, ISBN-13: 978-1-25-900492-6
2. C.S Venkataratnam: “Industrial Relations”, Oxford University Press, New Delhi, ISBN-0199456550

Web Links:

1. <https://nptel.ac.in/courses/110103506>
2. <https://enine.digimat.in/nptel/courses/video/122102007/L21.html>

Relevant cases have to be discussed in each unit and in examination case study is compulsory from any unit.

LABOUR WELFARE AND LEGISLATION

	L	T	P	C
Course Code: 244MS045	3	0	0	3

Course Outcomes:

At the end of the Course, Student will be able to:

- CO1:** Explain the key provisions and implications of major welfare legislations in India.
- CO2:** Identify the fundamental aspects of industrial relations legislation, including the Industrial Disputes Act, Industrial Employment Act, and Trade Unions Act.
- CO3:** Examine the main provisions of wage and social security legislation.
- CO4:** Analyze the role of the Indian constitution and various agencies in promoting labor welfare.
- CO5:** Classify statutory and non-statutory labor welfare programs.

Mapping of Course Outcomes with Program Outcomes:

CO/PO	PO1	PO2	PO3	PO4	PO5	PO6	PO7	PO8
CO1	-	-	-	2	-	-	-	-
CO2	-	-	-	2	-	-	-	-
CO3	-	-	-	2	-	-	-	-
CO4	-	-	-	2	-	-	-	-
CO5	-	-	-	2	-	-	-	-

Mapping of Course Outcomes with Program Specific Outcomes:

CO/PSO	PSO1	PSO2	PSO3
CO1	2	-	-
CO2	2	-	-
CO3	2	-	-
CO4	2	-	-
CO5	2	-	-

UNIT – I

Welfare Legislation: Factories Act 1948, Mines Act 1952, Plantation Labor Act 1951, Contract Labor (Regulation and Abolition) Act 1970 and A.P. Shops and Establishments Act

UNIT – II

Industrial Relations Legislation: Industrial Disputes Act 1947; Industrial Employment (standing orders) Act 1946 and Trade Unions Act 1926.

UNIT – III

Wage and Social Security Legislation: Payment of wages Act 1936 - Minimum wages Act 1948 - Payment of Bonus Act 1966 - Payment of Gratuity Act 1972 - Workmen's Compensation Act 1923 - Employees State Insurance Act 1948 - Maternity Benefit Act 1961 and Employees Provident Fund and Miscellaneous Provisions Act 1952.

UNIT – IV

Labor Welfare: Concept, scope and philosophy, principles of labor welfare, Indian constitution on labor, Agencies of labor welfare and their role. Impact of ILO on labor welfare in India. Labor problems – Indebtedness, Absenteeism, Alcoholism, Personal and Family Counselling.

UNIT – V

Labor Welfare Programmes: Statutory and non-statutory, extra mural and intra mural, Central Board of Workers' Education; Workers' Cooperatives; Welfare Centers, Welfare Officers' Role, Status and Functions. Role of social work in industry

Text Books:

1. Malik, P.L: "Industrial Law", Eastern Book Company. Lucknow, ISBN- 9789350280913,
2. Moorthy, M.V: "Principles of Labor Welfare", Oxford University Press, New Delhi, Open Library- OL5176374M,LCCN-74902549,OCLC/WorldCat-65284

Reference Books:

1. Pant, S.C: "Indian Labor Problems", Chaitanya Pub. House. Allahabad, ISBN-OCLC Number:43991387.
2. Labor And Industrial Laws, Fourth Edition, ADHIPHI Learning Pvt. Ltd., 1 Jul 2019, ISBN- 978-9388028936.

Web Links:

1. https://onlinecourses.nptel.ac.in/noc24_mg104/preview
2. <https://www.youtube.com/watch?v=KpsTCmK6TbU>

Relevant cases have to be discussed in each unit and in examination case study is compulsory from any unit.

COMPENSATION AND REWARD MANAGEMENT

	L	T	P	C
Course Code: 244MS046	3	0	0	3

Course Outcomes:

At the end of the Course, Student will be able to:

- CO1:** Explain the fundamental concepts and theories of compensation management
- CO2:** Analyze various pay structures based on job analysis and evaluation.
- CO3:** Identify different types of employee benefits and rewards
- CO4:** Examine the key provisions of Legislation and Compensation Acts.
- CO5:** Simplify the concept of expatriate Compensation.

Mapping of Course Outcomes with Program Outcomes:

CO/PO	PO1	PO2	PO3	PO4	PO5	PO6	PO7	PO8
CO1	2	-	-	-	-	-	-	-
CO2	-	-	-	2	-	-	-	-
CO3	-	-	-	2	-	-	-	-
CO4	-	-	-	2	-	-	-	-
CO5	-	-	-	2	-	-	-	-

Mapping of Course Outcomes with Program Specific Outcomes:

CO/PSO	PSO1	PSO2	PSO3
CO1	2	-	-
CO2	2	-	-
CO3	2	-	-
CO4	2	-	-
CO5	2	-	-

UNIT – I

Compensation Management An Introduction to Compensation Management, Theories of Compensation management, 3–P Concept in Compensation Management, Strategic Compensation Management, Strategic and Tactical Compensation Issues.

UNIT – II

Job Design, Job Evaluation and Compensation structures Job Analysis & Design, Job evaluation and methods, understanding market pay and benchmarking, Base pay, Performance based pay, Competency based pay and Team based pay.

UNIT – III

Benefits and Services Employee benefits and rewards, Long–term and Short–term benefits and rewards, Administration of benefits and the influencing factors, Employee welfare and services,

UNIT – IV

Legalization and Compensation The legislative process – Payment of Wages Act 1936, Employees Insurance Act 1948, Workers Compensation Act 1923, Employees Provident Fund Act 1952.

UNIT – V

Executive and International Compensation Executive compensation – concepts and elements, Quantitative tools, Expatriate Compensation and its Objectives, Elements of Expatriate's Compensation Package, Laws relating compensation.

Text Books:

1. Compensation Management– by Dipak Kumar Bhattacharyya, ISBN-9780199456543
2. Compensation Management in a Knowledge – based World 10th Edition (English, Paperback, Richard I. Henderson), PEARSON, ISBN-8131711102

Reference Books:

1. Compensation Management 2nd Edition (English, Paperback, Dipak Kumar Bhattacharyya), Oxford, ISBN-9780199456543
2. Compensation and Reward Management Wage and Salary Administration and Benefits by R. C. Sharma, Sulabh Sharma, ISBN- 9781032888026

Web Links:

1. <https://dituniversity.digimat.in/nptel/courses/video/110105069/L10.html>
2. https://www.youtube.com/watch?v=iY6e_NDCJgM

Relevant cases have to be discussed in each unit and in examination case study is compulsory from any unit.

DATA ANALYSIS WITH R

Course Code: 244MS047

L	T	P	C
2	0	1	3

Course Outcomes:

At the end of the Course, Student will be able to:

- CO1:** Configure and utilize the R environment to import and manage data for analytical purposes.
- CO2:** Apply R data structures and variables to organize and manipulate different types of data effectively.
- CO3:** Implement loops, functions, and control structures in R.
- CO4:** Extract and process web data, and perform text mining using R packages.
- CO5:** Apply data mining and machine learning techniques.

Mapping of Course Outcomes with Program Outcomes:

CO/PO	PO1	PO2	PO3	PO4	PO5	PO6	PO7	PO8
CO1	-	2	-	-	-	-	-	-
CO2	-	2	-	-	-	-	-	-
CO3	-	2	-	-	-	-	-	-
CO4	-	2	-	-	-	-	-	-
CO5	-	2	-	-	-	-	-	-

Mapping of Course Outcomes with Program Specific Outcomes:

CO/PSO	PSO1	PSO2	PSO3
CO1	-	2	-
CO2	-	2	-
CO3	-	2	-
CO4	-	2	-
CO5	-	2	-

UNIT – I

Introduction to R: Introduction to data analytics, data types and data models, History and Evolution of R, R Features, R environment setup, R basic syntax, R command prompt, R script file, how to import data into R and R packages

UNIT – II

R Data Structures, Data Types and Variables: Studying Vectors, defining factors, defining list, data frames, Matrixes, and arrays, understanding R variables, Data type of variable, Type of operators, what is R decision making, Understanding R if statement, R switch statement.

UNIT – III

R- Loops, Functions, Strings, Vectors, Arrays and Factors: Loops, User defined function, Control structures, data manipulation using r, String construction, R vector creation, access, Manipulate and merge list, Access array elements, Studying R factors, Generate factor levels.

UNIT – IV

R Web Data and Text Mining: Write read Binary file, understanding XML files, Studying R data bases, understanding R my SQL, Query, update tables and rows, create/ drop table using MySQL, Text mining using RQDA and JGR package.

UNIT – V

Data Mining and Machine Learning: Introduction to data mining and machine learning, Support vector machines (SVM), neural networks and deep learning, Model evaluation and hyper parameter tuning.

Text Books:

1. R for Data science, Dan Toomy, Packt Publishing Ltd.2014, ISBN 978-1-78439-086-0, ISBN-1784390860
2. Sandip Rakshit, R Programming for Beginners, McGraw Hill Education (India), ISBN-9352604555.

Reference Books:

1. "Text Mining with R: A Tidy Approach" by Julia Silge and David Robinson Silge, Julia, and David Robinson. Text Mining with R: A Tidy Approach. O'Reilly Media, ISBN-1491981652.
2. Introductory Statistics with R, Peter Dalgaard, Springer Science + Business Media, LLC, ISBN:978-0-387-79053-4

Web Links:

1. https://onlinecourses.nptel.ac.in/noc22_ma34/preview
2. <https://www.coursera.org/learn/data-analysis-r>

Relevant cases have to be discussed in each unit and in examination case study is compulsory from any unit.

MARKETING ANALYTICS

Course Code: 244MS048	L	T	P	C
	2	0	1	3

Course Outcomes:

At the end of the Course, Student will be able to:

- CO1:** Explain the Concepts of Marketing Analytics and their relevance in business,
- CO2:** Make use of MS Excel to deal with Marketing Data at basic level,
- CO3:** Appreciate Customer's journey through Product Selection Process and Customer Lifetime Value,
- CO4:** Conduct Analysis in Determining the Pricing Strategies
- CO5:** Analyze the Process of Optimizing Clusters and Measure the Effectiveness of Promotion

Mapping of Course Outcomes with Program Outcomes:

CO/PO	PO1	PO2	PO3	PO4	PO5	PO6	PO7	PO8
CO1	-	2	-	-	-	-	-	-
CO2	-	2	-	-	-	-	-	-
CO3	-	2	-	-	-	-	-	-
CO4	-	2	-	-	-	-	-	-
CO5	-	2	-	-	-	-	-	-

Mapping of Course Outcomes with Program Specific Outcomes:

CO/PSO	PSO1	PSO2	PSO3
CO1	-	2	-
CO2	-	2	-
CO3	-	2	-
CO4	-	2	-
CO5	-	2	-

UNIT – I

Introduction to Marketing Analytics: Definition, Need and Scope of Marketing Analytics, Marketing Analytics Vs. Marketing Research, Levels in Marketing Analytics, Adoption and Application of Marketing Analytics, Marketing Analytics and Business Intelligence. MS Excel as a Tool for conduction of Marketing Analytics. Using MS Excel to Organize and Summarize Marketing Data: Creation of Pivot Tables and Organizing Data.

UNIT – II

Summarizing Marketing Data: Summarizing Revenue Data: Month-wise and Product-wise. Slicing & Dicing of Data: Pareto Principle, Report Filters and Slicers. Demographic Analysis: Analyzing Sales Data by Age, Gender, Income and Location, Construction of Crosstabs of Two Demographic Variables. Using GETPIVOT Function for Pulling Data. Adding Data Labels and Data Tables.

UNIT – III

Customer Analytics: Customer Journey Mapping and the Process of Mapping (How to). Metrics for Tracking Customer Experience: Customer Feedback Metrics & Behaviour Derived Customer Metrics. Customer Persona, Building a Customer Persona and its Benefits, Parts of Buyer Persona. What Customer Wants: Using Conjoint Analysis for Levels in Consumer Decision Process in Product Choices and Product Attributes. Customer Lifetime Value (CLV). Calculating Customer Lifetime Value: Creating the Basic Customer Value Template, Measuring Sensitivity Analysis with Two-Way Tables, Estimating the Chance if Customer is still Active.

UNIT – IV

Pricing Analytics: Pricing, Goals of Pricing, Price Elasticity, Estimating Linear and Power Demand Curves, Using Excel Solver to Optimize Price, Incorporating Complementary Products, Using Solver Table to Price Multiple Products and Finding Demand Curve for All Products. Price Bundling, Bundling Prices to Extract Consumer Surplus, Mixed Bundling, Using Evolutionary Solver to Find Optimal Bundle Prices. Price Skimming.

UNIT – V

Segmentation & Promotion Analytics: Segmentation Analytics- Cluster Analysis and its Applications, Location-wise Clustering, Using Solver to find Optimal Clusters. Using Conjoint Analysis to Segment a Market, Using Decision Trees for Segmenting the Market. Promotion Analytics: Promotions and Types of Promotions, Discounting & Types of Discounting. Measuring the Effectiveness of Advertising: The Adstock Model. Media Selection Models: Linear Media Allocation Model, Quantity Discounts, Monte Carlo Media Allocation Simulation. Pay per Click Advertising.

Text Books:

1. Seema Gupta & Avadhoot Jathar, Marketing Analytics, Wiley, 2021, ISBN-9354242626.
2. Wayne L. Winston, Marketing Analytics: Data Driven Techniques with Microsoft Excel, ISBN-111837343X.

Reference Books:

1. Mike Grigsby, Marketing Analytics, Kogan Page, EAN: 9781398608191.
2. Robert Kozielski, Measuring Marketing Analytics, Emerald Publishing, ASIN: B074DTP4K4

Web Links:

1. https://onlinecourses.nptel.ac.in/noc20_mg30/preview
2. <https://archive.nptel.ac.in/courses/110/105/110105142/>

Relevant cases have to be discussed in each unit and in examination case study is compulsory from any unit.

FINANCIAL ANALYTICS

Course Code: 244MS049

L	T	P	C
2	0	1	3

Course Outcomes:

At the end of the Course, Student will be able to:

- CO1:** Examine financial statements to interpret organizational financial health.
- CO2:** Apply time value of money and risk-return measures to make financial decisions.
- CO3:** Analyze investment opportunities using capital budgeting techniques
- CO4:** Assess equity valuations and perform industry, economic, and technical analysis.
- CO5:** Interpret bond valuation and immunization strategies to manage fixed-income portfolios effectively.

Mapping of Course Outcomes with Program Outcomes:

CO/PO	PO1	PO2	PO3	PO4	PO5	PO6	PO7	PO8
CO1	-	2	-	-	-	-	-	-
CO2	-	2	-	-	-	-	-	-
CO3	-	2	-	-	-	-	-	-
CO4	-	2	-	-	-	-	-	-
CO5	-	2	-	-	-	-	-	-

Mapping of Course Outcomes with Program Specific Outcomes:

CO/PSO	PSO1	PSO2	PSO3
CO1	-	2	-
CO2	-	2	-
CO3	-	2	-
CO4	-	2	-
CO5	-	2	-

UNIT – I

Techniques of Financial Statement: Horizontal, Vertical Analysis, Trend Analysis, Ratio Analysis, Liquidity, Profitability, Solvency and Turnover Ratio, Valuation of Ratios, Statement of Cash Flow, Classification of Cash Flow, Computing Net Cash Flow: Operating, Investing and Financing Activities. Reporting and Interpretation using Spreadsheet.

UNIT – II

Time Value of Money: Future Value: Simple, Compound Interest and Annuity, Present Value: Discounted, Annuity, Equated Loan Amortization, Perpetuity using Spreadsheets. Risk and Return- Holding Period Returns, Arithmetic Mean vs Geometric Mean, Risk: Standard Deviation, Coefficient of Variation, Beta, Covariance of Stock.

UNIT – III

Capital Budgeting Techniques: Payback Period, Accounting Rate of Return, Net Present Value, Internal Rate of Return, Profitability Index, Decision Tree, Cash Flow in Capital Budgeting, Cost of Capital, Advance Capital Budgeting Techniques, Adjusted Present Value Approach, Competing Project Risk using Spreadsheets.

UNIT – IV

Equity Valuation: Calculation of Portfolio Mean and Variance, Capital Asset Pricing Model (CAPM), Variance: Covariance Matrix, Estimating Beta and Security Market Line. Industry Analysis, Economic Analysis and Technical Analysis in Stock, Real Option in Capital Budgeting.

UNIT – V

Bond Valuation: Duration, Duration of Bond with Uneven Payments, Immunization Strategies, Modelling the Term Structure, Calculating Expecting Bond Return in a Single and Multi-period Framework, Semi-annual Transition Matrix, Computation of Bond Beta.

Text Books:

1. Vijay Gupta, Financial Analysis using Excel, VJ Books Inc, Canada. ISBN- 978-0-470-27560
2. Timothy Mayes, Financial Analysis with MS Excel, Cengage, 7e, ISBN-8131533999.

Reference Books:

1. Sheeba Kapil, Financial Valuation and Modeling, Wiley, 1e,2022, ISBN-9354246036.
2. R. Narayanaswamy, Financial Accounting-Managerial Perspective, PHI,7e,2022, ISBN-9354246036.

Web Links:

1. <https://www.coursera.org/learn/applying-data-analytics-business-in-finance>
2. <https://www.udemy.com/course/financial-analytics-excel-tableau/>

Relevant cases have to be discussed in each unit and in examination case study is compulsory from any unit.

HR ANALYTICS

Course Code: 244MS050	L	T	P	C
	2	0	1	3

Course Outcomes:

At the end of the Course, Student will be able to:

- CO1:** Develop an understanding of the relevance of HR Analytics in the current scenario.
- CO2:** Explain the models of conducting HR Analytics
- CO3:** Make use of MS Excel for conduction of HR Analytics for key HR Processes
- CO4:** Classify various tools and software technologies used for conduction of descriptive HR Analytics and Visualization of HR Data.
- CO5:** Assess the significance of Predictive and Prescriptive Analytics.

Mapping of Course Outcomes with Program Outcomes:

CO/PO	PO1	PO2	PO3	PO4	PO5	PO6	PO7	PO8
CO1	-	2	-	-	-	-	-	-
CO2	-	2	-	-	-	-	-	-
CO3	-	2	-	-	-	-	-	-
CO4	-	2	-	-	-	-	-	-
CO5	-	2	-	-	-	-	-	-

Mapping of Course Outcomes with Program Specific Outcomes:

CO/PSO	PSO1	PSO2	PSO3
CO1	-	2	-
CO2	-	2	-
CO3	-	2	-
CO4	-	2	-
CO5	-	2	-

UNIT – I

Introduction to HR Analytics: History of Different HRM Perspectives, Transition from HRM to HCM and Gaining Sustainable Advantage through HCM. HR Analytics and Changing Role of HR Professionals. Importance, Scope and Benefits of HR Analytics. Levels of Analysis and Conducting analytics. Key Influencers of HR Analytics Process. Big Data Era in HR Analytics, HR Analytics – Linkage to Business Outcomes.

UNIT – II

Understanding HR Analytics: Conducting HR Analytics: Models of HR Analytics, How to Conduct HR Analytics. Understanding HR Data: Importance of Data, Types and Scales of Data, Methods of Capturing Data, Data Examination & Purification. Understanding various HR Metrics from the perspective of HR Analytics.

UNIT – III

Analytics for Key HR Processes Using MS Excel: HR Analytics for Recruitment & Selection, Training & Development, Performance Appraisal, Talent Management, Employee Engagement, Compensation Management and Expatriate Management.

UNIT – IV

Descriptive Analytics: Overview of Select Tools for Conduction HR Analytics: MS Excel, R, Tableau, Power BI, Python, SPSS & PSPP. Descriptive Analytics in HR: HR Dashboards using MS Excel, Slicing and Dicing of HR Data using MS Excel Pivot Table Applications, Data Visualization for Key HR processes.

UNIT – V

Predictive & Prescriptive HR Analytics: Predictive HR Analytics: Correlation, Linear and Multiple Regression, Factor Analysis and Cluster Analysis, Comparison of Means and Analysis of Variance for Manpower Demographics, Employee Satisfaction, And Training Effectiveness etc. Prescriptive HR Analytics, Predictive vs Prescriptive HR Analytics, Future of HR Analytics.

Text Books:

1. Rama Shankar Yadav & Sunil Maheshwari, HR Analytics, Wiley, 2021, ISBN-9390421551.
2. Pratyush Banerjee, Jatin Pandey & Manish Gupta, HR Analytics: Practical Applications of HR Analytics, Sage, 2019, ISBN-9353282969.

Reference Books:

1. Nishant Uppal, Human Resource Analytics, Pearson, 2021, ISBN-13: 978-9390168408.
2. Bharti Motwani, HR Analytics: Practical Approach Using Python, Wiley, 2021, ISBN-10. 935424002X.

Web Links:

1. https://onlinecourses.nptel.ac.in/noc24_hs126/preview
2. <https://www.coursera.org/learn/human-resources-analytics>

Relevant cases have to be discussed in each unit and in examination case study is compulsory from any unit.

PREDICTIVE ANALYTICS

Course Code: 244MS051	L	T	P	C
	2	0	1	3

Course Outcomes:

At the end of the Course, Student will be able to:

- CO1:** Explain descriptive, predictive, and prescriptive analytics, and assess their applications.
- CO2:** Examine qualitative forecasting methods to make informed predictions and distinguish them.
- CO3:** Implement linear regression techniques using Excel to analyze and predict relationships between variables.
- CO4:** Apply moving averages for forecasting and evaluate their effectiveness using Excel.
- CO5:** Simplify and structure various types of documents using various tools.

Mapping of Course Outcomes with Program Outcomes:

CO/ PO	PO1	PO2	PO3	PO4	PO5	PO6	PO7	PO8
CO1	-	2	-	-	-	-	-	-
CO2	-	2	-	-	-	-	-	-
CO3	-	2	-	-	-	-	-	-
CO4	-	2	-	-	-	-	-	-
CO5	-	2	-	-	-	-	-	-

Mapping of Course Outcomes with Program Specific Outcomes:

CO/P SO	PSO1	PSO2	PSO3
CO1	-	2	-
CO2	-	2	-
CO3	-	2	-
CO4	-	2	-
CO5	-	2	-

UNIT – I

Introduction to Predictive Analytics: Definition of Analytics advantage and limitation of analytics – Definition of predictive analytics –Introduction to Descriptive analytics, Predictive analytics, Prescriptive analytics (theory only) - Applications and limitation of predictive analytics.

UNIT – II

Forecasting with Qualitative Methods: Meaning of Qualitative forecasting – Methods of Qualitative forecasting – Criteria to select method of forecasting - Application areas of Qualitative methods - Differentiation between Qualitative and Quantitative forecasting methods.

UNIT – III

Linear Regression: Correlation and Regression - Charting the Relationship - Calculating Pearson's Correlation Coefficient- Simple Regression – Array - Entering Formulas- Multiple

Regression – LINEST function with Multiple Predictors - Using Excel.

UNIT – IV

Forecasting with Moving Averages: About Moving Averages – Types of moving averages
Signal and Noise- Lost Periods -Smoothing Versus Tracking - Criteria for Judging Moving
Averages - Mean Absolute Deviation - Least Squares – Using Excel.

UNIT – V

Working with Documents: Defining purpose and scope documents, Understanding structure
of documents – case studies, articles, white papers, technical reports, minutes of meeting
Documentation formats and Styles. Document preparation tools – PowerPoint, Word and
Excel.

Text Books:

1. "Essentials of Business analytics descriptive predictive prescriptive", Cengage publishing house. (Student's Handbook for Associate Analytics - III), ISBN-9781285187273.
2. Kotu, Vijay, Bala Deshpande, "Predictive Analytics and Data Mining: Concepts and Practice with RapidMiner", 1st Edition, ISBN-13978-0128014608

Reference Books:

1. Eric Siegel, "Predictive Analytics: The Power to Predict Who Will Click, Buy, Lie, or Die Paperback – Illustrated, Wiley Publications, ISBN-13-978-1119145677
2. Conrad Carlberg, "Predictive Analytics: Microsoft Excel Paperback – Illustrated, ISBN-0789749416

Web Links:

1. https://onlinecourses.nptel.ac.in/noc23_ma46/preview
2. <https://www.coursera.org/learn/predictive-analytics>

Relevant cases have to be discussed in each unit and in examination case study is compulsory from any unit.

BIG DATA ANALYTICS

Course Code: 244MS052	L	T	P	C
	2	0	1	3

Course Outcomes:

At the end of the Course, Student will be able to:

- CO1:** Explain big data futures and classification of analytics
- CO2:** Develop knowledge on analytics flow for big data and big data stack
- CO3:** Analyze big data tool using Hadoop
- CO4:** Identify the security related aspects in big data
- CO5:** Discover various application areas of big data

Mapping of Course Outcomes with Program Outcomes:

CO/PO	PO1	PO2	PO3	PO4	PO5	PO6	PO7	PO8
CO1	-	2	-	-	-	-	-	-
CO2	-	2	-	-	-	-	-	-
CO3	-	2	-	-	-	-	-	-
CO4	-	2	-	-	-	-	-	-
CO5	-	2	-	-	-	-	-	-

Mapping of Course Outcomes with Program Specific Outcomes:

CO/PSO	PSO1	PSO2	PSO3
CO1	-	2	-
CO2	-	2	-
CO3	-	2	-
CO4	-	2	-
CO5	-	2	-

UNIT – I

Introduction to Big Data: What is Analytics- Descriptive Analytics, Diagnostic Analytics, Predictive Analytics and Prescriptive Analytics? What is Big Data- Characteristics of Big Data- Volume, Velocity, Variety, Veracity and Value?

UNIT – II

Analytics Flow and Big Data Stack: Analytics Flow for Big Data- Data Collection, Data Preparation, Analysis Types, Analysis Modes, Visualizations, Big Data Stack- Raw Data Sources, Data Access Connectors, Data Storage, Batch Analytics, Real-time Analytics, Interactive Querying, Serving Databases, Web & Visualization Frameworks

UNIT – III

Big Data -Hadoop: NoSQL, Comparison of SQL and NoSQL, Hadoop -RDBMS Versus Hadoop - Distributed Computing Challenges – Hadoop Overview - Hadoop Distributed File System – Processing Data with Hadoop - Managing Resources and Applications with Hadoop YARN - Interacting with Hadoop Ecosystem

UNIT – IV

Security in Big Data: Security, compliance, auditing, and protection pragmatic steps to securing/ big data -classifying data- protecting big data analytics- big data and compliance-the intellectual property challenge.

UNIT – V

Big Data Applications: Business Specification Examples of Big Data- Financial, Web, Healthcare, Internet of Things, Environment, Logistics & Transportation, Industry, Retail.

Text Books:

1. Anand Rajaraman and Jeffrey David Ullman, "Mining of Massive Datasets", Cambridge University Press, ISBN-9781139924801.
2. David Loshin, "Big Data Analytics: From Strategic Planning to Enterprise Integration with Tools, Techniques, NoSQL, and Graph", Morgan Kaufmann/El sevier Publisher, ISBN-0124173195.

Reference Books:

1. EMC Education Services, "Data Science and Big Data Analytics: Discovering, Analyzing, Visualizing and Presenting Data", Wiley publishers, ISBN 978-1-118-87613-8.
2. Bart Baesens, "Analytics in a Big Data World: The Essential Guide to Data Science and its Applications", Wiley Publishers. ISBN: 978-1118892701

Web Links:

1. https://onlinecourses.swayam2.ac.in/arp19_ap60/preview
2. <https://www.coursera.org/specializations/big-data>

Relevant cases have to be discussed in each unit and in examination case study is compulsory from any unit.

WEB ANALYTICS

Course Code: 244MS053	L	T	P	C
	2	0	1	3

Course Outcomes:

At the end of the Course, Student will be able to:

- CO1:** Explain the importance of analytics in the context of social media and websites, emphasizing the role of data - driven decision – making.
- CO2:** Familiarize participants with fundamental metrics used in web analytics and social media analytics.
- CO3:** Identify the key performance indicators (KPIs) for social media and web analytics.
- CO4:** Show how to set up and track conversions on websites and social media platforms and understand the customer journey and optimize for conversion goals.
- CO5:** Analyze the concepts of social listening and monitoring and use tools to monitor brand mentions, track sentiment, and stay informed about industry trends.

Mapping of Course Outcomes with Program Outcomes:

CO/PO	PO1	PO2	PO3	PO4	PO5	PO6	PO7	PO8
CO1	-	2	-	-	-	-	-	-
CO2	-	2	-	-	-	-	-	-
CO3	-	2	-	-	-	-	-	-
CO4	-	2	-	-	-	-	-	-
CO5	-	2	-	-	-	-	-	-

Mapping of Course Outcomes with Program Specific Outcomes:

CO/PSO	PSO1	PSO2	PSO3
CO1	-	2	-
CO2	-	2	-
CO3	-	2	-
CO4	-	2	-
CO5	-	2	-

UNIT – I

Introduction- Introduction to Web - Limitations of current Web – Development of Semantic Web– Emergence of the Social Web – Statistical Properties of Social Networks - Network analysis -Development of Social Network Analysis - Key concepts and measures in network analysis -Discussion networks - Blogs and online communities - Web-based networks.

UNIT – II

Modeling and Visualization- Visualizing Online Social Networks - A Taxonomy of visualizations - Graph Representation - Centrality- Clustering - Node-Edge Diagrams - visualizing Social Networks with Matrix-Based Representations- Node-Link Diagrams – Hybrid Representations - Modeling and aggregating social network data – Random Walks and their Applications –Use of Hadoop and Map Reduce – Ontological representation of social individuals and relationships.

UNIT – III

Mining Communities- Aggregating and reasoning with social network data- Advanced Representations - Extracting evolution of Web Community from a Series of Web Archive -Detecting Communities in Social Networks - Evaluating Communities – Core Methods for Community Detection & Mining - Applications of Community Mining Algorithms – Node Classification in Social Networks.

UNIT – IV

Text and Opinion Mining- Text Mining in Social Networks -Opinion extraction – Sentiment classification and clustering - Temporal sentiment analysis - Irony detection in opinion mining -Wish analysis - Product review mining – Review Classification – Tracking sentiments towards topics over time.

UNIT – V

Tools for Social Network Analysis- UCINET – PAJEK – ETDRAW – Stoc NET – Splus –R – NodeXL – SIENA and RSIENA – Real world Social Networks (Facebook-Twitteretc.)

Text Books:

1. Charu C. Aggarwal, “Social Network Data Analytics”, Springer, ISBN-978-1-4419-8462-3.
2. Peter Mika, “Social Networks and the Semantic Web”, 1st edition, Springer, ISBN-1441943722.

Reference Books:

1. GuandongXu, Yanchun Zhang and Lin Li, “Web Mining and Social Networking – Techniques and applications”, 1st edition, Springer, ISBN-144197735X.
2. Giles, Mark Smith, John Yen, “Advances in Social Network Mining and Analysis”, Springer, ISBN-978-3-642-14929-0.

Web Links:

1. https://onlinecourses.nptel.ac.in/noc22_mg68/preview
2. <https://www.coursera.org/professional-certificates/google-data-analytics>

Relevant cases have to be discussed in each unit and in examination case study is compulsory from any unit.

DATA MINING & MACHINE LEARNING

Course Code: 244MS054	L	T	P	C
	2	0	1	3

Course Outcomes:

At the end of the Course, Student will be able to:

- CO1:** Explore the kinds of data that can be mined, major issues in data mining, and the societal impact of data mining.
- CO2:** Determine reasons for data preprocessing, major tasks involved, and techniques for data cleaning, reduction, transformation, and discretization.
- CO3:** Analyze the machine learning concepts, types of algorithms, and specific supervised learning algorithms.
- CO4:** Illustrate the user-based and item-based similarity in recommender systems, calculate cosine similarity, and address challenges with similarity measures.
- CO5:** Summarize the decision trees, building classifiers using gini criteria and entropy criteria. Measure test accuracy, display decision trees, find optimal criteria,

Mapping of Course Outcomes with Program Outcomes:

CO/PO	PO1	PO2	PO3	PO4	PO5	PO6	PO7	PO8
CO1	-	2	-	-	-	-	-	-
CO2	-	2	-	-	-	-	-	-
CO3	-	2	-	-	-	-	-	-
CO4	-	2	-	-	-	-	-	-
CO5	-	2	-	-	-	-	-	-

Mapping of Course Outcomes with Program Specific Outcomes:

CO/PSO	PSO1	PSO2	PSO3
CO1	-	2	-
CO2	-	2	-
CO3	-	2	-
CO4	-	2	-
CO5	-	2	-

UNIT – I

Introduction to Data Mining: Data Mining; Kinds of data that can be mined-Database Data, Data Warehouses, Transactional Data, Other Kinds of Data; Major Issues in Data Mining-Mining Methodology, User Interaction, Efficiency and Scalability, Diversity of Database Types, Data Mining and Society.

UNIT – II

Data Preprocessing: An Overview-Reasons to process the data, Major Tasks in Data Preprocessing; Data Cleaning-Missing Values, Noisy Data, Data Cleaning as a Process; Data Reduction-Principal Component Analysis, Histograms, Clustering, Sampling, Data Cube Aggregation; Data Transformation and Data Discretization-Data Transformation by Normalization, Discretization by Binning, Discretization by Histogram Analysis.

UNIT – III

Machine Learning: What is Machine Learning; Types of Machine Learning Algorithms-Supervised, Unsupervised and Reinforcement Learning. Supervised Learning-K Nearest Neighbors, Random Forest and Boosting

UNIT – IV

Recommender Systems Using Machine Learning: User Based Similarity-Calculating Cosine Similarity Between Users, Filtering Similar Users, Challenges with User Based Similarity. Item Based Similarity-Calculating Cosine Similarity between Movies, Finding Most Similar Movies. Matrix Factorization.

UNIT – V

Decision Tree Classification: Introduction to Decision Tree; Building Decision Tree Classifier using Gini Criteria; Measuring Test Accuracy; Displaying the Tree; Building Decision Tree Classifier using Entropy Criteria. Finding Optimal Criteria; Maximum Depth of the Tree and Benefits and Disadvantages of Decision Tree Case Study: Applying Decision Tree Classification on German Credit Data.

Text Books:

- 1 Max Bramer and Springer “Principles of Data Mining 2020” 8th edition, 2020, ISBN-9781447174929.
- 2 Sergio’s Theodoratos, Elsevier “Machine Learning a Bayesian and Optimization Perspective “, 1st edition, 2020, ISBN-0128015225.

Reference Books:

- 1 Shalev-Shwartz, Ben-David, “Understanding ML from Theory to Algorithms”, 1st edition, Cambridge University Press, ISBN-978-1107057136
- 2 Stephen Marsland, Machine Learning - An Algorithmic Perspective, 2nd edition, CRC Press, ISBN-1466583282.

Web Links:

- 1 https://onlinecourses.nptel.ac.in/noc21_cs06/preview
- 2 <https://www.coursera.org/specializations/machine-learning-introduction>

Relevant cases have to be discussed in each unit and in examination case study is compulsory from any unit.

LOGISTICS MANAGEMENT

Course Code: 244MS055	L	T	P	C
	3	0	0	3

Course Outcomes:

At the end of the Course, Student will be able to:

- CO1:** Analyse the interdependencies between logistics and other business functions (e.g., marketing, production, finance).
- CO2:** Explore the different logistical activities.
- CO3:** Identify the development of supply chain strategy
- CO4:** Examine the logistical operational integration and supply chain relationships
- CO5:** Assess the role of Supply Chain in e-business and b2b practices

Mapping of Course Outcomes with Program Outcomes:

CO/PO	PO1	PO2	PO3	PO4	PO5	PO6	PO7	PO8
CO1	-	-	-	2	-	-	-	-
CO2	-	-	-	2	-	-	-	-
CO3	-	-	-	2	-	-	-	-
CO4	-	-	-	2	-	-	-	-
CO5	-	-	-	2	-	-	-	-

Mapping of Course Outcomes with Program Specific Outcomes:

CO/PSO	PSO1	PSO2	PSO3
CO1	2	-	-
CO2	2	-	-
CO3	2	-	-
CO4	2	-	-
CO5	2	-	-

UNIT – I

Logistics Management and Supply Chain Management - Definition, Evolution, Importance. The concepts of logistics. Logistics relationships. Functional applications – HR, Marketing, Operations, Finance, IT. Logistics Organization - Logistics in different industries

UNIT – II

Logistics Activities: – functions, objectives, solution. Customer Service, Warehousing and Material Storage, Material Handling, order processing, information handling and procurement Transportation and Packaging. Third party and fourth party logistics - Reverse Logistics - Global Logistics

UNIT – III

Fundamentals of Supply Chain and Importance: Development of SCM concepts and Definitions Supply chain strategy, Strategic Supply Chain Management and Key components. Drivers of Supply Chain Performance – key decision areas – External Drivers of Change.

UNIT – IV

Modelling Logistics Systems - Simulation of logistic systems - Dimensions of Logistics & SCM – The Macro perspective and the macro dimension – Logistic system analysis strategy, Logistical Operations Integration, Customer service – Supply Chain Relationships

UNIT – V

Framework and Role of Supply Chain in E-business and B2B practices: Value of information in logistics & SCM - E-logistics, E-Supply Chains - International and global issues in logistics - Role of government in international logistics and Principal characteristics of logistics in various countries and regions

Text Books:

1. Supply Chain Logistics Management, Bowersox, Closs, Cooper, McGraw Hill. 5th Edition, (9th reprint), 2021, ISBN-0078096642
2. World Class Supply Management, Burt, Dobbler, Starling, TMH., 2019, ISBN-0070499330.

Reference Books:

1. Logistical Management, Donald J Bowersox, David J Closs, TMH, 9th Edition, ISBN-9780070435544
2. Reguram G, Rangaraj N., Logistics and Supply Chain Management Cases and Concepts: Macmillan India Ltd., New Delhi, ISBN- 9780070221635.

Web Links:

1. <https://archive.nptel.ac.in/courses/110/105/110105141/>
2. <https://www.youtube.com/watch?v=Nrl0CtS1m8Y>

Relevant cases have to be discussed in each unit and in examination case study is compulsory from any unit.

STORE KEEPING AND WAREHOUSING MANAGEMENT

Course Code: 244MS056	L	T	P	C
	3	0	0	3

Course Outcomes:

At the end of the Course, Student will be able to:

- CO1:** Explain the aspects of store house operations.
- CO2:** Develop the layout of container terminals and equipment used in container terminals.
- CO3:** Discover the benefits and issues in logistics outsourcing
- CO4:** Prioritize the objectives of warehousing management and automation in warehouse operations
- CO5:** Analyze warehouse layout and design and understand sustainable warehousing practices.

Mapping of Course Outcomes with Program Outcomes:

CO/PO	PO1	PO2	PO3	PO4	PO5	PO6	PO7	PO8
CO1	-	-	-	-	2	-	-	-
CO2	-	-	-	-	2	-	-	-
CO3	-	-	-	-	2	-	-	-
CO4	-	-	-	-	2	-	-	-
CO5	-	-	-	-	2	-	-	-

Mapping of Course Outcomes with Program Specific Outcomes:

CO/PSO	PSO1	PSO2	PSO3
CO1	2	-	-
CO2	2	-	-
CO3	2	-	-
CO4	2	-	-
CO5	2	-	-

UNIT – I

Storehouse Operations and Control: Introduction, Objectives, Store house Operations and its Objectives, Daily Activities of Stores, Organizing a Store, Store Location and Layout, Selecting appropriate storage system, Centralization, Decentralization and variety reduction of stores, Store Housekeeping, Stores Accounting.

UNIT – II

Infrastructure and Layout of Container Terminals: Infrastructure and layout of container terminals - Berth and quay characteristics- Apron width, quay crane rails - Container yard size, layout and markings - Container Freight Station (CFS) -Gates, offices, maintenance facilities, fencing and traffic control. Types and purpose of equipment used in container terminals - Ship to shore handling equipment - Yard equipment for transfer, storage and delivery - CFS and other terminal equipment Terminal automation

UNIT – III

Logistics Outsourcing: Introduction, Objectives, Concept of Logistics Outsourcing, Catalyst for logistics outsourcing, Benefits of logistics outsourcing, Issues in logistics outsourcing, Third-Party Logistics, Fourth-Party Logistics, Selection of Logistics Service Provider, Logistics Service Contract, Outsourcing-Value Proposition.

UNIT – IV

Warehousing Operations and Management: Objectives of warehousing management; Physical control and security; Automation and IT systems in warehouse operations and management.

UNIT – V

Warehouse Layout and Design: Warehouse layout and design, Optimal space utilization, workflow efficiency, and ergonomic design. Improving storehouse speed, space optimization, Sustainable Warehousing- Integrating green processes and eco-friendly materials. Reducing the industry's carbon footprint.

Text Books:

1. David Simchi, Levi, Philip Kaminsky, Ravi Shankar. Designing & Managing the Supply Chain: Tata McGraw Hill. 14th Edition, ISBN-9386601990.
2. Managing Supply Chains: A Logistics Approach, Coyle, J.J., Jr. Langley, C.J., Novack, R.A, & Gibson, B.J. (9th ed.), McGraw Hill, ISBN-9788131521250

Reference Books:

1. World-Class Warehousing and Material Handling. Edward, F. (International ed.), McGraw-Hill.Muller, ISBN-13978-0071842822.
2. Designing and Managing the Supply Chain: Concepts, Strategies and Case Studies, Simchi-Levi, D., Kaminsky, P., & Simchi-Levi, E. (3rd ed.), McGraw-Hill, ISBN-9386601990.

Web Links:

1. <https://archive.nptel.ac.in/courses/110/105/110105095/>
2. <http://acl.digimat.in/nptel/courses/video/110105141/L29.html>

Relevant cases have to be discussed in each unit and in examination case study is compulsory from any unit.

TRANSPORTATION AND INFRASTRUCTURE MANAGEMENT FOR SCM

	L	T	P	C
Course Code: 244MS057	3	0	0	3

Course Outcomes:

At the end of the Course, Student will be able to:

- CO1:** Identify the features of logistics transportation.
- CO2:** Interpret the features of railway logistics.
- CO3:** Examine the features, facilities and suitability of roadways
- CO4:** Explain the port operations and services.
- CO5:** Apply knowledge of air transport to develop efficient and effective air cargo operations.

Mapping of Course Outcomes with Program Outcomes:

CO/PO	PO1	PO2	PO3	PO4	PO5	PO6	PO7	PO8
CO1	-	-	-	2	-	-	-	-
CO2	-	-	-	2	-	-	-	-
CO3	-	-	-	2	-	-	-	-
CO4	-	-	-	2	-	-	-	-
CO5	-	-	-	2	-	-	-	-

Mapping of Course Outcomes with Program Specific Outcomes:

CO/PSO	PSO1	PSO2	PSO3
CO1	2	-	-
CO2	2	-	-
CO3	2	-	-
CO4	2	-	-
CO5	2	-	-

UNIT – I

Transportation and Logic: significance of transportation logistics: utility created by transportation in logistics transportation as a means of conquering time and space features of inbound, outbound, local and medium, long and continental transportation- features of logistics Transportation.

UNIT – II

Railway and Logistics Contours: Features and facilities offered by Railways Factors influencing growth in Rail Logistics- Suitability for different Cargo and distance Ranges segments – Innovative.

UNIT – III

Roadways and Logistics Contours: Roadways as a primary mode and complementary mode of transportation in Logistics – Features, Facilities and suitability- Innovations in road ways to make it Logistics-friendly- Factors influencing choice- Factors influencing growth in Road Logistics- Suitability for different Cargo and distance Ranges segments –Innovative schemes/facilities to popularize rail logistics in India- Share of Railways in Cargo movement in India and world-wide. Role of National Highways and the Toll highways- Outsourcing Fleets from others-Technology, Cost, Speed, Security and Dynamics- Competition with other Modes

UNIT – IV

Water Transport and Port Operations: Introduction to water transport, Main services, Services and facilities for ships -Administrative formalities - Cargo transfer - Services and facilities for cargo Berths and Terminals - Berth Facilities and Equipment -ship Operation – Pre shipment planning, the stowage plan and on-board stowage - cargo positioning and stowage on the terminal - Developments in cargo/container handling and terminal operation - Safety of cargo operations - Cargo security: Measuring and evaluating performance and productivity.

UNIT – V

Air Transport: Introduction to Air Transport – Air Freight – IATA –Cargo Handling at Goods at Air Port – Information Management of Air Cargo – System and Modules – Distribution of Goods.

Text Books:

1. MB. Stroh., A Practical Guide to Transportation and Logistics: Logistics Network Inc, ISBN-0970811519.
2. MOSWest., Transportation and Cargo Security: Prentice Hall, ISBN-0131703560.

Reference Books:

1. Ritter, Barrett and Wilson, Securing Global Transportation Networks: McGraw Hill, ISBN- 0071477519.
2. Port Management and Operations, MARIA G. BURNS., CRS Press, U.K, ISBN-9781482206753

Web Links:

1. <https://archive.nptel.ac.in/courses/110/106/110106045/>
2. <https://elearn.nptel.ac.in/shop/iit-workshops/completed/supply-chain-management/?v=c86ee0d9d7ed>

Relevant cases have to be discussed in each unit and in examination case study is compulsory from any unit.

PURCHASING AND MATERIAL MANAGEMENT

Course Code: 244MS058

L	T	P	C
3	0	0	3

Course Outcomes:

At the end of the Course, Student will be able to:

- CO1:** Apply the role of purchasing and materials planning in push and pull system.
- CO2:** Simplify pricing models, negotiation techniques, and cost analysis.
- CO3:** Analyze the purpose and significance of inventory within organizations.
- CO4:** Explore the objectives and types of materials handling.
- CO5:** Differentiate between packing and packaging.

Mapping of Course Outcomes with Program Outcomes:

CO/PO	PO1	PO2	PO3	PO4	PO5	PO6	PO7	PO8
CO1	-	2	-	-	-	-	-	-
CO2	-	2	-	-	-	-	-	-
CO3	-	2	-	-	-	-	-	-
CO4	-	2	-	-	-	-	-	-
CO5	-	2	-	-	-	-	-	-

Mapping of Course Outcomes with Program Specific Outcomes:

CO/PSO	PSO1	PSO2	PSO3
CO1	2	-	-
CO2	2	-	-
CO3	2	-	-
CO4	2	-	-
CO5	2	-	-

UNIT – I

Role of Purchasing and Materials Management- objectives, organization and Inter relationships, Determination and Description of material Quantity, Material planning in push and pull system, MRP and JIT.

UNIT – II

Purchase System and Procedures: - objectives, purchasing function, Purchasing polices and decisions, make or Buy vender selection and Rating, Timing of purchase, price determination, purchase procedures and system public purchasing and tendering.

UNIT – III

Inventory Management – Introduction of inventory system, Function of Inventory and Relevant cost concept, classification of Inventory systems, Inventory Models: Deterministic Discount, EOQ EBQ, MRP – I, selective Inventory Management ABC, VED, FSN, PQR.

UNIT – IV

Materials Handling: Materials handling systems and objectives; Types of handling equipment; Selection of the most appropriate equipment in specific situations, Traffic and Transportation, Disposal of Scrap, waste management waste reduction approach, waste collection, Recycling waste disposal system, materials information system.

UNIT – V

Packing and Packaging: Meaning, Functions and Essentials of Packing- Packaging: Meaning, Functions and Essentials of Packaging- Difference between Packing and Packaging-Packing for Storage- Packing for Overseas Shipment- Packing for Inland Transportation- Packaging for Product content Protection - Test of packaging: Mechanical, Climatic & Lab test- International Care labelling code - Packaging cost.

Text Books:

1. Integrated Materials Management, Putta, A.K, New McGraw Hill, ISBN-978-8120300279
2. Handbook of Materials Management, Gopalakrishan P. and Sanderashan M New Delhi prentice Hall of India, ASIN: B00K7YGKRQ.

Reference Books:

1. Proactive Procurement, Burt, David N, Englewood Cliffs, New Jersey, Prentice Hall Inc, ISBN-0137114656.
2. Purchasing and Material Management, Dobler, D.W. etc., New York, McGraw Hill, ISBN-0070370478

Web Links:

1. <https://archive.nptel.ac.in/courses/110/105/110105095/>
2. https://onlinecourses.nptel.ac.in/noc20_mg17/preview

Relevant cases have to be discussed in each unit and in examination case study is compulsory from any unit.

REVERSE LOGISTICS

Course Code: 244MS059	L	T	P	C
	3	0	0	3

Course Outcomes:

At the end of the Course, Student will be able to:

- CO1:** Explain the differences between forward and reverse logistics
- CO2:** Develop the commercial reverse logistics in the field of apparel, aviation, retail, automotive, electronics, food, beverage and sporting goods
- CO3:** Analyze the importance of customer service returns and after service customer support as applied to reverse logistics
- CO4:** Assess how green buildings enhance energy efficiency, reduce environmental impact, and improve occupant well-being.
- CO5:** Estimate the influence of organizational culture on reverse logistics practices.

Mapping of Course Outcomes with Program Outcomes:

CO/PO	PO1	PO2	PO3	PO4	PO5	PO6	PO7	PO8
CO1	-	-	-	2	-	-	-	-
CO2	-	-	-	2	-	-	-	-
CO3	-	-	-	2	-	-	-	-
CO4	-	-	-	2	-	-	-	-
CO5	-	-	-	2	-	-	-	-

Mapping of Course Outcomes with Program Specific Outcomes:

CO/PSO	PSO1	PSO2	PSO3
CO1	2	-	-
CO2	2	-	-
CO3	2	-	-
CO4	2	-	-
CO5	2	-	-

UNIT – I

Reverse Logistics and Forward Logistics: Commercial logistics and the military, Measuring reverse logistics and improvement best practices of military reverse logistics, Management of complex systems and reverse logistics

UNIT – II

Reverse Logistics Principles: Successful management principles are successful reverse logistics principles, best practices in retail, apparel, electronics, food, beverage, and sporting goods

UNIT – III

Customer Service Returns: RMA and other elements of returns best practices in customer service and after sales customer support Reverse logistics concerns of the secondary market.

UNIT – IV

Green Reverse Logistics: Green reverse logistics practices green buildings that support logistics (LEED Certification) Successful global projects.

UNIT – V

Organizational Culture and Reverse Logistics: organizational culture and review how it applies to reverse logistics Review cultural design to support reverse logistics Reduction of risk in the reverse supply chain Securing the supply chain.

Text Books:

1. Quantitative Models for Closed-Loop Supply Chains, Rommert Dekker, Moritz Fleischmann, Karl Inder furth, and Luk N., 5th Edition (9th reprint), 2019, ISBN-9783642073809.
2. supply Chain Management: A Logistics Perspective, John J. Coyle, C. John Langley Jr., Robert A. Novack, Brian Gibson, 5th Edition, 2020, ISBN-10:1305859979.

Reference Books:

1. Donald J. Bowerson, Logistic and Supply Chain Management: Prentice Hall of India, ISBN-978-43566789.
2. Business Logistics/Supply Chain Management, H. K Das, Er. Rajnish Verma, S. Chand Publications, Pearson Education India; 5th edition ISBN- 6780649073809.

Web Links:

1. https://onlinecourses.nptel.ac.in/noc24_hs128/preview
2. https://ocw.mit.edu/courses/esd-s43-green-supply-chain-management-spring2014/resources/mitesd_s43s14_lecture4/

Relevant cases have to be discussed in each unit and in examination case study is compulsory from any unit.

SUPPLY CHAIN RISK MANAGEMENT

	L	T	P	C
Course Code: 244MS060	3	0	0	3

Course Outcomes:

At the end of the Course, Student will be able to:

- CO1:** Identify and assess potential risks in a supply chain, including operational, financial, and reputational risks.
- CO2:** Design and implement a supply chain risk management framework that aligns with industry best practices.
- CO3:** Assess the effects of natural disasters, pandemics, and climate change on supply chain operations.
- CO4:** Explain key risk management concepts, including risk assessment, mitigation, and transfer, with relevant examples.
- CO5:** Apply the key principles of designing a resilient supply chain, including flexibility, agility, and adaptability.

Mapping of Course Outcomes with Program Outcomes:

CO/PO	PO1	PO2	PO3	PO4	PO5	PO6	PO7	PO8
CO1	-	-	-	2	-	-	-	-
CO2	-	-	-	2	-	-	-	-
CO3	-	-	-	2	-	-	-	-
CO4	-	-	-	2	-	-	-	-
CO5	-	-	2	-	-	-	-	-

Mapping of Course Outcomes with Program Specific Outcomes:

CO/PSO	PSO1	PSO2	PSO3
CO1	2	-	-
CO2	2	-	-
CO3	2	-	-
CO4	2	-	-
CO5	2	-	-

UNIT – I

Introduction of Risks Management: Concept and Process, An Action-Based Framework for Supply Chain Risk, Identification of Operational Hazards, Risk Assessment and Valuation, Tactical Risk Decisions and Crisis Management, Strategic Risk Mitigation, Four Operational Hedging Strategies.

UNIT – II

Operational Strategy for Managing Supply Chain Risks: Introduction, Stockpile Inventory, Diversify Supply, Backup Supply, Manage Demand, Ambiguity in Risks. Decentralized Risks Management Strategy. Shared risks; Achieving an integrated approach; Identifying risks, Analyzing and responding to risks

UNIT – III

Managing Supply Chain Disruption: Economic Risks to Supply Chain-Demand Shock, Currency Fluctuation, Supply Shock, Industrial Unrest, Impacts of Natural Disasters, pandemics and Climate Change, Societal Risks to Supply chain, Risks and Security in Air

Cargo Supply chain, Time-Based Risk Management-Response Time and Impacts, Risk and Reward Considerations.

UNIT – IV

Approaches to Risk Management: Identifying Risks and its Types, Tools for Analysing Past Events, Tools to Collect Opinions, Tools to Analyse Operations, Problems with Risks Identification, Conceptual Explanations with Examples, Development of Risk Management Techniques, Supply Chain Risk Management (SCRM) and aims of SCRM.

UNIT – V

Creating Resilient Supply Chains: Concept of Resilient Supply Chain, Principles of Designing a Resilient Supply Chain, Physical Features of a Resilient Supply Chain, relationships within a Resilient Supply Chain, Risk Compensation and Business Continuity. Latest updates in Resilient Supply Chain.

Text Books:

1. Supply Chain Risks Management, Donald Water, (Kogan Pages), ISBN-970749448547.
2. Handbook for Supply Chain and Risks Management (MeriPustak), Omra Khan & George Zsidisn, ISBN-9788131521878

Reference Books:

1. Supply Chain Risk Management: Advanced Tools, Models, and Developments, YacobKhojasteh, (Springer), ISBN-13:978-9811041051
2. Managing Supply Chain Risk: Integrating with Risk Management, Bret Wagner, SimeCurkovic, and Thomas Scannell, ISBN:9781040084625.

Web Links:

1. http://ndl.iitkgp.ac.in/he_document/nptel/nptel/courses_110_108_110108056_video_lec9
2. http://ndl.iitkgp.ac.in/he_document/nptel/courses_110_108_110108056_video_lec11

Relevant cases have to be discussed in each unit and in examination case study is compulsory from any unit.

ENTERPRISE RESOURCE PLANNING

	L	T	P	C
Course Code: 244MS061	3	0	0	3

Course Outcomes:

At the end of the Course, Student will be able to:

- CO1:** Make use of Enterprise software, and its role in integrating business function
- CO2:** Analyze the strategic options for ERP identification and adoption
- CO3:** Design the ERP implementation strategies.
- CO4:** Apply reengineering business processes for successful ERP implementation.
- CO5:** Summarize emerging trends in Enterprise Resource Planning

Mapping of Course Outcomes with Program Outcomes:

CO/PO	PO1	PO2	PO3	PO4	PO5	PO6	PO7	PO8
CO1	-	2	-	-	-	-	-	-
CO2	-	2	-	-	-	-	-	-
CO3	-	2	-	-	-	-	-	-
CO4	-	2	-	-	-	-	-	-
CO5	-	2	-	-	-	-	-	-

Mapping of Course Outcomes with Program Specific Outcomes:

CO/PSO	PSO1	PSO2	PSO3
CO1	-	2	-
CO2	-	2	-
CO3	-	2	-
CO4	-	2	-
CO5	-	2	-

UNIT – I

Introduction: Overview of enterprise systems – Evolution - Risks and benefits - Fundamental technology -Issues to be consider in planning design and implementation of cross functional integrated ERP systems

UNIT – II

ERP Solutions and Functional Modules: Overview of ERP software solutions- small, medium and large enterprise vendor solutions, BPR, and best business practices - Business process Management

UNIT – III

ERP Implementation: Planning Evaluation and selection of ERP systems - Implementation life cycle - ERP implementation, Methodology and Frame work- Data Migration. People Organization in implementation.

UNIT – IV

Post Implementation: Maintenance of ERP- Organizational and Industrial impact; Success and Failure factors of ERP Implementation.

UNIT – V

Emerging Trends on ERP: Extended ERP systems and ERP add-ons -CRM, SCM, Business analytics - Future trends in ERP systems

Text Books:

1. Enterprise Resource Planning, Alexis Leon, second edition, Tata McGraw-Hill, ISBN-9780070656802.
2. ERP in Practice, Mahadeo Jaiswal and Ganesh Vanapalli, Tata McGraw-Hill. ISBN-9781403927453.

Reference Books:

1. Manufacturing Resource Planning (MRP II) with Introduction to ERP; SCM; Khalid Sheikh, McGraw-Hill, ISBN-9785634590
2. The Impact of Enterprise Systems on Corporate Performance, K.B.Hendricks; V.R. Singhal, Elsevier, ISBN-978-79-3567-2

Web Links:

1. <https://www.coursera.org/learn/understanding-the-enterprise-systems-environment>
2. <https://www.coursera.org/learn/enterprise-systems>

Relevant cases have to be discussed in each unit and in examination case study is compulsory from any unit.

INTERNATIONAL LOGISTICS MANAGEMENT

	L	T	P	C
Course Code: 244MS062	3	0	0	3

Course Outcomes:

At the end of the Course, Student will be able to:

- CO1:** Explain the concept of logistics integration and barriers to integration.
- CO2:** Identify the international marketing and channels and modes of transport.
- CO3:** Develop the multimodal transport characteristics and tariff structures.
- CO4:** Assess the benefits and constraints of containerization and Chartering Containerization
- CO5:** Prepare and manage customs documentation, including commercial invoices, bills of lading, and certificates of origin.

Mapping of Course Outcomes with Program Outcomes:

CO/PO	PO1	PO2	PO3	PO4	PO5	PO6	PO7	PO8
CO1	-	-	-	2	-	-	-	-
CO2	-	-	-	2	-	-	-	-
CO3	-	-	-	2	-	-	-	-
CO4	-	-	-	2	-	-	-	-
CO5	-	-	-	2	-	-	-	-

Mapping of Course Outcomes with Program Specific Outcomes:

CO/PSO	PSO1	PSO2	PSO3
CO1	2	-	-
CO2	2	-	-
CO3	2	-	-
CO4	2	-	-
CO5	2	-	-

UNIT – I

Overview Logistics: Definition, Evolution, Concept, Components, Importance, Objectives; Logistic Subsystem; The work of Logistics; Integrated Logistics; Barrier to Internal Integration.

UNIT – II

Marketing and Logistics: Customer Focused Marketing; International Marketing: Introduction, Definition, Basis for International Trade, Process, Importance; International Marketing Channel: Role of Clearing Agent, Various Modes of Transport, Choice and Issues for Each Mode, Transport Cost Characteristics

UNIT – III

Basics of Transportation- Transportation functionality and Principles; Multimodal Transport: Modal Characteristics; Modal Comparisons; Legal Classifications; International Air Transport; Air Cargo Tariff Structure; Freight: Definition, Rate; Freight Structure and Practice

UNIT – IV

Containerization and Chartering Containerization: Genesis, Concept, Classification, Benefits and Constraints; Inland Container Depot (ICD): Roles and Functions, CFS, Export Clearance at ICD; CONCOR; ICDs under CONCOR; Chartering: Kinds of Charter, Charter Party, and Arbitration.

UNIT – V

Special Aspects of Export logistics: Picking, Packing, Vessel Booking [Less-than Container Load (LCL) / Full Container Load (FCL)], Customs, Documentation, Shipment, Delivery to distribution centres, distributors and lastly the retail outlets- Import Logistics: Documents Collection- Valuing- Bonded Warehousing- Customs Formalities

Text Books:

1. Supply Chain Logistics Management, Bowersox, Closs, Cooper, McGraw Hill, ISBN-9780071326216.
2. World Class Supply Management, Burt, Dobbler, Starling, TMH, ISBN-9780071123105.

Reference Books:

1. Logistical Management, Donald J Bowersox, David J Closs, TMH, ISBN-9780071326216
2. “International Logistics”, Pierre David, Biztantra, ISBN-9780759391437.

Web Links:

1. <https://www.vskills.in/certification/certified-international-logistics-management-professional-course-outline>
2. <https://archive.nptel.ac.in/courses/110/108/110108056/>

Relevant cases have to be discussed in each unit and in examination case study is compulsory from any unit.

DATA MINING FOR BUSINESS DECISIONS

Course Code: 244MS063	L	T	P	C
	2	0	1	3

Course Outcomes:

At the end of the Course, Student will be able to:

- CO1:** Explain the fundamental concepts and principles of data mining and its applications.
- CO2:** Differentiate between Business Intelligence and Data Mining.
- CO3:** Identify and interpret clustering results using appropriate metrics and visualization techniques.
- CO4:** Analyze the principles and techniques of Web Mining, including web content mining, web structure mining, and web usage mining.
- CO5:** Determine the importance of data mining in transforming raw data into actionable knowledge.

Mapping of Course Outcomes with Program Outcomes:

CO/PO	PO1	PO2	PO3	PO4	PO5	PO6	PO7	PO8
CO1	-	2	-	-	-	-	-	-
CO2	-	2	-	-	-	-	-	-
CO3	-	2	-	-	-	-	-	-
CO4	-	2	-	-	-	-	-	-
CO5	-	2	-	-	-	-	-	-

Mapping of Course Outcomes with Program Specific Outcomes:

CO/PSO	PSO1	PSO2	PSO3
CO1	-	2	-
CO2	-	2	-
CO3	-	2	-
CO4	-	2	-
CO5	-	2	-

UNIT – I

Introduction to Data Mining: Introduction-- Scope of Data Mining-- What is Data Mining-- How does Data Mining Works-- Predictive Modelling-- Data Mining and Data Warehousing-- Architecture for Data Mining: Profitable Applications-- Data Mining Tools:

UNIT – II

Business Intelligence: Introduction, Business Intelligence-- Business Intelligence tools-- Business Intelligence Infrastructure-- Business Intelligence Applications-- BI versus Data Warehouse--BI versus Data Mining-- Future of BI. Data Preprocessing: Introduction-- Data Preprocessing Overview-- Data Cleaning-- Data Integration and Transformation-- Data Reduction-- Discretization and Concept Hierarchy Generation.

UNIT – III

Data Mining Techniques an Overview: Introduction-- Data Mining-- Data Mining Versus Database Management System-- Data Mining Techniques- Association rules— Classification— Regression—Clustering-- Neural networks. Clustering—Introduction— Clustering-- Cluster

Analysis-- Clustering Methods- K means-- Hierarchical clustering-- Agglomerative clustering-- Divisive clustering-- clustering and segmentation software-- evaluating clusters.

UNIT – IV

Web Mining: Introduction—Terminologies-- Categories of Web Mining – Web Content Mining- - Web Structure Mining-- Web Usage Mining-- Applications of Web Mining and Agent based and Data base approaches-- Web mining Software.

UNIT – V

Applications of Data Mining: Introduction-- Business Applications Using Data Mining Risk management and targeted marketing-- Customer profiles and feature construction-- Medical applications (diabetic screening) -- Scientific Applications using Data Mining-- Other Applications.

Text Books:

1. Introduction to data mining by Tan, Steinbach & Kumar, ISBN-10:9332571402.
2. Data Mining: Concepts and Techniques, Third Edition by Han, Kamber& Pei, ISBN-9781558604896.

Reference Books:

1. Data Mining and Analysis Fundamental Concepts and Algorithms by Zaki&Meira, ISBN-9780521766333.
2. Data Mining: The Textbook by Aggarwal, ISBN-10:9783319141411.

Web Links:

1. https://onlinecourses.nptel.ac.in/noc21_cs06/preview
2. <https://ggsestc.digimat.in/nptel/courses/video/110105089/L39.html>

Relevant cases have to be discussed in each unit and in examination case study is compulsory from any unit.

MANAGING SOFTWARE PROJECTS

	L	T	P	C
Course Code: 244MS064	2	0	1	3

Course Outcomes:

At the end of the Course, Student will be able to:

- CO1:** Demonstrate leadership skills, including stakeholder management, communication, and conflict resolution, essential for project success.
- CO2:** Apply cost estimation, resource allocation, and budgeting techniques to manage project finances effectively.
- CO3:** Conduct qualitative and quantitative risk analysis to evaluate the likelihood and impact of risks on project objectives.
- CO4:** Navigate legal and regulatory frameworks governing procurement, contracting, and outsourcing activities.
- CO5:** Develop leadership qualities necessary for guiding and motivating project teams toward achieving project objectives.

Mapping of Course Outcomes with Program Outcomes:

CO/PO	PO1	PO2	PO3	PO4	PO5	PO6	PO7	PO8
CO1	-	-	3	-	2	-	-	-
CO2	3	-	-	-	-	2	-	-
CO3	-	3	-	2	-	-	-	-
CO4	-	-	-	3	-	-	2	-
CO5	-	-	3	-	2	-	-	-

Mapping of Course Outcomes with Program Specific Outcomes:

CO/PSO	PSO1	PSO2	PSO3
CO1	3	-	-
CO2	3	-	-
CO3	3	-	-
CO4	3	-	-
CO5	3	-	-

UNIT – I

Introduction: What is project, what is project Management -The role of project Manager, the project Management Profession, Project life cycle - A system view of project management · Understanding organizations, Stakeholder management - Project phases and the project life cycle -The context of information technology projects.

UNIT – II

Developing the Project Schedule: Project management software tools-Developing the project budget, Finalizing the project schedule and budget -Monitoring and controlling the project -The project communications plan -Project metrics- Reporting performance and progress - Information distribution.

UNIT – III

Risk Management Planning: Common sources of risk on information technology projects Risk identification, Qualitative risk analysis - Quantitative risk analysis, Risk response planning-Risk monitoring and control, using software to assist in project risk management

UNIT – IV

Planning Purchase and Acquisitions: Planning contracting, requesting seller responses
Selecting sellers, Administering the contract- Closing the contract - Using software to assist
in project management – Outsourcing

UNIT – V

Project Leadership: Ethics in projects -Multicultural projects- Project implementation,
administrative closure - Project evaluation

Text Books:

1. Information Technology Project Management: Kathy Schwalbe Thomson Publication, ISBN-9780619035280.
2. Information Technology Project Management providing measurable organizational value Jack Marchewka Wiley India, ISBN-13:978-1118911013.

Reference Books:

1. Applied software project management Stellman& Greene SPD, ISBN-. 9780596009489
2. Software Engineering Project Management by Richard Thayer, Edward Yourdon WILEY INDIA, ISBN-.9780818680007.

Web Links:

1. <http://www.digimat.in/nptel/courses/video/106105218/L01.html>
2. https://onlinecourses.nptel.ac.in/noc19_cs70/preview

Relevant cases have to be discussed in each unit and in examination case study is compulsory from any unit.

WEB DESIGNING

	L	T	P	C
Course Code: 244MS065	2	0	1	3

Course Outcomes:

At the end of the Course, Student will be able to:

- CO1:** Explain the history and evolution of the web and its underlying technologies.
- CO2:** Develop the HTTP message format and differentiate between persistent and non-persistent connections.
- CO3:** Construct web pages using HTML, including text, lists, links, images, tables, forms, frames, and meta tags.
- CO4:** Design and develop visually appealing web pages using CSS layout techniques.
- CO5:** Apply advanced JavaScript techniques, such as event handling and DOM manipulation.

Mapping of Course Outcomes with Program Outcomes:

CO/PO	PO1	PO2	PO3	PO4	PO5	PO6	PO7	PO8
CO1	-	3	-	-	-	-	-	-
CO2	-	3	-	-	-	-	-	-
CO3	-	3	-	-	-	-	-	-
CO4	-	3	-	-	-	-	-	-
CO5	-	3	-	-	-	-	-	-

Mapping of Course Outcomes with Program Specific Outcomes:

CO/PSO	PSO1	PSO2	PSO3
CO1	-	3	-
CO2	-	3	-
CO3	-	3	-
CO4	-	3	-
CO5	-	3	-

UNIT – I

Web Fundamentals: Introduction To the Web, History of the Web, Protocols Governing the Web, Creating Websites for Individuals and the Corporate World, Web Applications, Writing Web Projects, Identification of Objects, Target User, Web Team, Planning and Process Development, Web Architecture, Major Issues in the Web Solutions Development, Web Servers (Apache Web Server), Web Browsers, Internet Standards, TCP/IP Protocol Suite, IP Addresses, MIME, Cyber Laws.

UNIT – II

Hyper Text Transfer Protocol (HTTP): Introduction - Web Server and Clients, Resources, URL and its Anatomy – Examples, Message Format, Persistent and Non-Persistent Connections, Web Caching, Proxy. Java Network Programming- Java and the Net, Java Networking Classes and Interfaces, Looking up Internet Address, Client/Server Programs, Socket Programming, E-mail Client. (lab sessions to be conducted)

UNIT – III

Hyper Text Markup Language (HTML): Introduction, Structure, Text, Lists, Links, Images, Tables, Forms, Frames, Images, and Meta Tags. (lab sessions to be conducted)

UNIT – IV

Cascading Style Sheets (CSS): Introduction, Advantages, Color, Text, Boxes, Lists, Tables and Forms, Layout, Images, HTML5 Layout. (Lab Sessions to be conducted)

UNIT – V

JavaScript: Introduction, Variables, Literals, Operators, Control Structure, Conditional Statements, Arrays, Functions, Objects, JavaScript and HTML DOM, Advanced JavaScript and HTML Forms (Lab sessions to be conducted).

Text Books:

- 1 Uttam K Roy: Web Technologies, Oxford University Press, ISBN-9780198066224.
- 2 Jon Duckett: HTML & CSS: Design and Build Websites – John Wiley & Sons, ISBN-9781118206911.

Reference Books:

- 1 Web Design with HTML & CSS: HTML & CSS Complete Beginner's Guide, Prem Kumar (Author), Notion Press, 31 October 2021, ISBN-978118008188.
- 2 Web Designing and Development Training Guide, Jain/ Rai/ Geetha, BPB, 2021, ISBN-10:8183335799.

Web Links:

- 1 <https://nptel.ac.in/courses/106106222>
- 2 <https://nptel.ac.in/courses/106106156>

Relevant cases have to be discussed in each unit and in examination case study is compulsory from any unit.

BUSINESS ANALYTICS

Course Code: 244MS066	L	T	P	C
	2	0	1	3

Course Outcomes:

At the end of the Course, Student will be able to:

- CO1:** Trace the historical development of business analytics from its origins to the present day.
- CO2:** Demonstrate proficiency in using Excel for data manipulation, formula application, and data queries.
- CO3:** Formulate and solve linear optimization models using spreadsheet software.
- CO4:** Analyze market data using frameworks like PESTLE and Porter's Five Forces to gain strategic insights.
- CO5:** Implement strategies for effective Master Data Management to ensure data consistency and accuracy across organizations.

Mapping of Course Outcomes with Program Outcomes:

CO/PO	PO1	PO2	PO3	PO4	PO5	PO6	PO7	PO8
CO1	-	3	-	-	-	-	-	-
CO2	3	-	-	-	-	2	-	-
CO3	3	-	-	-	-	2	-	-
CO4	-	3	-	2	-	-	-	-
CO5	-	3	-	-	-	2	-	-

Mapping of Course Outcomes with Program Specific Outcomes:

CO/PSO	PSO1	PSO2	PSO3
CO1	-	3	-
CO2	-	3	-
CO3	-	3	-
CO4	-	3	-
CO5	-	3	-

UNIT – I

Introduction to Business Analytics: Evolution of Business analytics, scope, Data for Business Analytics, Models in Business Analytics, problem solving with business analytics- Types of data, Integrating Analytics with business, Business Analytics for Competitive Advantage, Descriptive, Predictive, and Prescriptive Analytics, Dashboards Business Analytics Process Cycle.

UNIT – II

Analytics on Spreadsheets: Basic Excel, Excel Formulas, Excel Functions, Data Queries. Descriptive Analytics: Descriptive Statistical measures - Populations and samples, Statistical notations, Measures of Location, Measures of Dispersion, and Measures of Association. Statistical Inference: Hypothesis testing, one-Sample Test, Two-Sample Test, Two tailed Hypothesis for mean, ANOVA. Predictive Analytics: Simple Linear regression, Multiple Linear regression, Residual Analysis, Building regression models, Regression with categorical independent variables.

UNIT – III

Machine Learning: Supervised Learning and Unsupervised Learning, Clustering & Segmentation, Affinity/ Association Analysis, Data Reduction, Visual Analytics and Data Visualization Prescriptive Analytics: Building Linear Optimization models, Implementing Linear Optimization models on spreadsheets, Solving Linear Optimization models.

UNIT – IV

Marketing Analytics: Models and metrics- Market Insight – Market data sources, sizing, PESTLE trend analysis, and porter five forces analysis - Market basket Analysis, Text Analytics, Spreadsheet Modeling - Sales Analytics: E Commerce sales mode, sales metrics, profitability metrics and support metrics.

UNIT – V

Introduction to Big Data: Master Data Management. Data Mining on what kind of data, what kinds of patterns can be mined, Which technologies are used, Which kinds of applications are targeted, Major issues in Data Mining. Getting to know your Data: Data Objects and Attribute Types, Basic Statistical Descriptions of Data, Data Visualization, Measuring data Similarity and Dissimilarity.

Text Books:

1. Analytics at Work by Thomas H. Davenport, Jeanne G.Harris and Robert Morison, Harvard Business Press, ISBN-13:978-1422177693.
2. Getting Started with Business Analytics: Insightful Decision – Making by David Hardoon, GalitShmueli, Chapman & Hall/CRC, ISBN-10:1439896534.

Reference Books:

1. Business Intelligence: A Managerial Approach by Efraim Turban, Ramesh Sharda, DursunDelen and Daid King, Pearson Publication, ISBN-9780133051056.
2. Business Intelligence Making Decision through Data Analytics, Jerzy Surma, Business Expert Press, ISBN- 9781606491850

Web Links:

1. <https://archive.nptel.ac.in/courses/110/105/110105089/>
2. https://onlinecourses.nptel.ac.in/noc24_cs65/preview

Relevant cases have to be discussed in each unit and in examination case study is compulsory from any unit.

MANAGING DIGITAL INNOVATION AND TRANSFORMATION

Course Code: 244MS067	L	T	P	C
	2	0	1	3

Course Outcomes:

At the end of the Course, Student will be able to:

- CO1:** Explain the concept of digital transformation and its importance in today's business environment.
- CO2:** Examine the requirements for social media transformation.
- CO3:** Identify and address challenges associated with building digital capabilities.
- CO4:** Analyze the need for re-organization to bridge the gap to digital customers.
- CO5:** Assess the impact of digital transformation on enterprise innovation.

Mapping of Course Outcomes with Program Outcomes:

CO/PO	PO1	PO2	PO3	PO4	PO5	PO6	PO7	PO8
CO1	-	3	-	-	-	-	-	-
CO2	-	3	-	-	-	-	-	-
CO3	-	3	-	2	-	-	-	-
CO4	-	3	-	2	-	-	-	-
CO5	-	3	-	-	-	2	-	-

Mapping of Course Outcomes with Program Specific Outcomes:

CO/PSO	PSO1	PSO2	PSO3
CO1	-	3	-
CO2	-	3	-
CO3	-	3	-
CO4	-	3	-
CO5	-	3	-

UNIT – I

Introduction to Digital Transformations: The five domains of digital transformations — customer, competition, data, innovation, and value, 1-farness customer networks, turn data into assets, adapt value proposition

UNIT – II

Classification of Digital Transformations: Business Model, product development, data, processes, knowledge, self—service, and organizational culture; Social Media Transformation: understand requirements, document goals, objective and social media tactics, establish potential future state operating model, gap analysis and recommendations.

UNIT – III

Building Digital Capabilities: challenges ongoing digital, handling employee during digital transformations, developing companywide strategy; Digital transformations in the space of cloud computing: prepare and drive digital transformations.

UNIT – IV

Digitalization of Professional Services: Re-Organisation in Order to Bridge the Gap to Digital Customers - Value Creation in Virtual Law Firms - Digital Transformation Supporting Public Service Innovation: Business Model Challenges and Sustainable - Development Opportunities

UNIT – V

Areas of IT Management and its Challenges: IT services, IT organization - Enterprise Innovation and the Digital Transformation - Industry, development trends, business competitiveness due to Technology - Using Technology as Innovation, Integration and Interconnection of business - IT strategy, IT governance, IT sourcing and controlling

Text Books:

1. Herbert, Lindsay; Digital Transformation: Build your organization's Future for the Innovation Age, Bloomsbury Publication, ISBN-10:1472940377.
2. Venkatraman, V; The Digital Matrix: New rules for business transformation through technology; Lifefree Media Ltd, ISBN-10:1928055206.

Reference Books:

1. Velte, A. T; Velte, T. J; and Elsenpeter, R; Cloud Computing: A Practical Approach, Mcgraw Hill Education (India) Private Limited, ISBN-0071626956.
2. Rogers, David, The Digital Transformation Playbook — Rethink your Business for the Digital Age (Columbia Business School Publishing), ISBN-10:0231163843.

Web Links:

1. https://onlinecourses.nptel.ac.in/noc24_mg74/preview
2. https://onlinecourses.swayam2.ac.in/imb23_mg69/preview

Relevant cases have to be discussed in each unit and in examination case study is compulsory from any unit.

BIG DATA ANALYTICS

Course Code: 244MS068	L	T	P	C
	2	0	1	3

Course Outcomes:

At the end of the Course, Student will be able to:

- CO1:** Explain the importance of Big Data and SQL databases with Hadoop.
- CO2:** Simplify how HDFS ensures data reliability and availability.
- CO3:** Relate Hive with traditional RDBMS systems and understand the differences.
- CO4:** Compare H Base with traditional RDBMS systems and understand when to use HBase.
- CO5:** Solve common graph-related problems using Map Reduce.

Mapping of Course Outcomes with Program Outcomes:

CO/PO	PO1	PO2	PO3	PO4	PO5	PO6	PO7	PO8
CO1	-	3	-	-	-	-	-	-
CO2	-	3	-	2	-	-	-	-
CO3	-	3	-	-	-	-	-	-
CO4	-	3	-	-	-	2	-	-
CO5	-	3	-	2	-	-	-	-

Mapping of Course Outcomes with Program Specific Outcomes:

CO/PSO	PSO1	PSO2	PSO3
CO1	-	3	-
CO2	-	3	-
CO3	-	3	-
CO4	-	3	-
CO5	-	3	-

UNIT – I

Introduction to Big Data: Big Data-definition, Characteristics of Big Data (Volume, Variety, Velocity, Veracity, Validity), Importance of Big Data , Patterns for Big Data Development, Data in the Warehouse and Data in Hadoop [Zikopoulos] - Introduction to Hadoop: Hadoop-definition, Understanding distributed systems and Hadoop, Comparing SQL databases and Hadoop, Understanding MapReduce, Counting words with Hadoop—running your first program, History of Hadoop, Starting Hadoop - The building blocks of Hadoop, Name Node, Data Node, Secondary Name Node, Job Tracker and Task Tracker.

UNIT – II

HDFS: Components of Hadoop -Working with files in HDFS, Anatomy of a Map Reduce program, Reading and writing the Hadoop Distributed File system -The Design of HDFS, HDFS Concepts, The Command-Line Interface, Hadoop File system, The Java Interface, Data Flow, Parallel Copying with distcp, Hadoop Archives. Hadoop I/O: Compression—Serialization-- Avro and File-Based Data structures.

UNIT – III

Map Reduce Programming: Writing basic Map Reduce programs - Getting the patent data set, constructing the basic template of a Map Reduce program, counting things, adapting for

Hadoop's API changes, Streaming in Hadoop. Map Reduce Advanced Programming: Advanced Map Reduce - Chaining Map Reduce jobs, joining data from different sources.

UNIT – IV

Hadoop Eco System: User Defined Functions-- Data Processing operators. Hive: Hive Shell-- Hive Services-- Hive Meta store-- Comparison with Traditional Databases—HiveQL-- Tables, Querying Data and User Defined Functions. HBase: H Basics—Concepts—Clients—Example—Hbase Versus RDBMS. Big SQL: Introduction

UNIT – V

Graph Representation in Map Reduce: Modeling data and solving problems with graphs, Shortest Path Algorithm, Friends-of-Friends Algorithm, PageRank Algorithm, Bloom Filters. Data Analytics with R Machine Learning: Introduction, Supervised Learning, Unsupervised Learning, Collaborative Filtering. Big Data Analytics with BigR.

Text Books:

1. Tom White — Hadoop: The Definitive Guide| Third Edit on, O 'reily Media, ISBN-10:9789352130672.
2. Seema Acharya, SubhasiniChellappan, "Big Data Analytics" Wiley, ISBN-13:978-8126579518.

Reference Books:

1. Michael Berthold, David J. Hand, "Intelligent Data Analysis|, Springer, ISBN-978-3-540-48625-1.
2. Jay Liebowitz, —Big Data and Business Analytics| Auerbach Publications, CRC press, ISBN-13:978-1466565784

Web Links:

1. <https://archive.nptel.ac.in/courses/106/104/106104189/>
2. https://onlinecourses.nptel.ac.in/noc20_cs92/preview

Relevant cases have to be discussed in each unit and in examination case study is compulsory from any unit.

CYBER LAWS & SECURITY

Course Code: 244MS069	L	T	P	C
	2	0	1	3

Course Outcomes:

At the end of the Course, Student will be able to:

- CO1:** Explain the meaning and concepts of cyber security.
- CO2:** Identify the importance of Secure System Planning and administration
- CO3:** Distinguish Information security policies and procedures in organizations
- CO4:** Compare and contrast the practical applications of Information security systems.
- CO5:** Conduct survey on Organizational and Human Security.

Mapping of Course Outcomes with Program Outcomes:

CO/PO	PO1	PO2	PO3	PO4	PO5	PO6	PO7	PO8
CO1	-	3	-	-	-	-	-	-
CO2	-	3	-	2	-	-	-	-
CO3	-	3	-	-	-	2	-	-
CO4	-	3	-	2	-	-	-	-
CO5	-	3	-	-	-	2	-	-

Mapping of Course Outcomes with Program Specific Outcomes:

CO/PSO	PSO1	PSO2	PSO3
CO1	-	3	-
CO2	-	3	-
CO3	-	3	-
CO4	-	3	-
CO5	-	3	-

UNIT – I

Introduction to Computer Security: Definition, Threats to security, Government requirements, Information Protection and Access Controls, Computer security efforts, Standards, Computer Security mandates and legislation, Privacy considerations, international security activity.

UNIT – II

Secure System Planning and Administration: Introduction to the orange book, Security policy requirements, accountability, assurance and documentation requirements, Network Security, The Red book and Government network evaluations.

UNIT – III

Information Security Policies and Procedures: Corporate policies- Tier 1, Tier 2 and Tier3 policies - process management-planning and preparation-developing policies-asset classification policy-developing standards.

UNIT – IV

Information Security: fundamentals-Employee responsibilities- information classification Information handling- Tools of information security- Information processing-secure program administration.

UNIT – V

Organizational and Human Security: Adoption of Information Security Management Standards, Human Factors in Security- Role of information security professionals.

Text Books:

1. Debby Russell and Sr. G.T Gangemi, "Computer Security Basics (Paperback)", 2nd Edition, O'Reilly Media, ISBN-13:978-0937175712.
2. Thomas R. Peltier, —Information Security policies and procedures: A Practitioner 's Referencell, 2nd Edition Prentice Hall, ISBN-13:978-08493111376.

Reference Books:

1. Kenneth J. Knapp, —Cyber Security and Global Information Assurance: Threat Analysis and Response Solutionsll, IGI Global, ISBN-10:1605663263.
2. Jonathan Rosenoer, —Cyber law: the Law of the Internetll, Springer-verlag. ISBN: 978-0-387-94832-4

Web Links:

1. <http://acl.digimat.in/nptel/courses/video/106106248/L14.html>
2. https://onlinecourses.swayam2.ac.in/nou19_cs08/preview

Relevant cases have to be discussed in each unit and in examination case study is compulsory from any unit.

INFORMATION SYSTEMS AUDIT

Course Code: 244MS070	L	T	P	C
	2	0	1	3

Course Outcomes:

At the end of the Course, Student will be able to:

- CO1:** Explain the meaning and concepts of Information System Auditing.
- CO2:** Analyze the importance of Management Control Framework.
- CO3:** Distinguish Management Control Framework for establishing effective controls.
- CO4:** Compare and contrast Evidence Evaluation systems.
- CO5:** Justify corporate governance issues in Indian context.

Mapping of Course Outcomes with Program Outcomes:

CO/PO	PO1	PO2	PO3	PO4	PO5	PO6	PO7	PO8
CO1	-	3	-	-	-	-	-	-
CO2	-	3	-	2	-	-	-	-
CO3	-	3	-	-	-	2	-	-
CO4	-	3	-	2	-	-	-	-
CO5	-	3	-	-	-	2	-	-

Mapping of Course Outcomes with Program Specific Outcomes:

CO/PSO	PSO1	PSO2	PSO3
CO1	-	3	-
CO2	-	3	-
CO3	-	3	-
CO4	-	3	-
CO5	-	3	-

UNIT – I

Overview of Information System Auditing: Effect of Computers on Internal Controls, Effects of Computers on Auditing, Foundations of information Systems Auditing, Conducting an Information Systems Audit.

UNIT – II

The Management Control Framework-I: Introduction, Evaluation the Planning Function, Leading Function and Controlling Function, Systems Development - Management Controls, Approaches to Auditing Systems Development, Normative Models of the Systems Development Process, Evaluating the Major phases in the Systems Development Process, Programming Management Controls, Data Resource Management Controls.

UNIT – III

The Management Control Framework-II: Security Management Controls, Operations Management Controls Quality Assurance Management Controls- Case Studies.

UNIT – IV

Evidence Collection: Audit Software, Code Review, Test Data, and Code Comparison, Concurrent Auditing techniques, Interviews, Questionnaires, and Control Flowcharts. Performance Management tools- Case Studies.

UNIT – V

Evidence Evaluation: Evaluating Asset Safeguarding and Data Integrity, Evaluating System Effectiveness, Evaluating System Efficiency. Information Systems Audit and Management: Managing the Information Systems Audit Function,

Text Books:

1. Ron Weber: —Information Systems Control and Auditl, Pearson Education, ISBN-13:978-8131704721.
2. D P Dube: Information System Audit and Assurance, TMH, New Delhi, ISBN-13:978-0070585690.

Reference Books:

1. Auditing Information Systems, Jack J. Champlain, Wiley, ISBN-13:978-0471281177.
2. Auditor's Guide to Information Systems Auditing, Richard E. Cascarino, Wiley, ISBN-13:978-0470009895.

Web Links:

1. <https://archive.nptel.ac.in/noc/courses/noc15/SEM1/noc15-cs03/>
2. <https://www.coursera.org/learn/information-systems-audit/reviews?page=9>

Relevant cases have to be discussed in each unit and in examination case study is compulsory from any unit.

DIGITAL STARTUP AND NEW VENTURE MANAGEMENT

Course Code: 244MS071	L	T	P	C
	3	0	0	3

Course Outcomes:

At the end of the Course, Student will be able to:

- CO1:** Identify various types of digital startups.
- CO2:** Estimate the capital and resource requirements for digital startups.
- CO3:** Examine the financial feasibility of digital startups.
- CO4:** Analyze the stages of growth for new ventures.
- CO5:** Develop strategies for dealing with failure.

Mapping of Course Outcomes with Program Outcomes:

CO/PO	PO1	PO2	PO3	PO4	PO5	PO6	PO7	PO8
CO1	-	-	-	3	2	-	-	-
CO2	3	-	-	2	-	-	-	-
CO3	-	-	2	3	-	-	-	-
CO4	-	2	-	3	-	-	-	-
CO5	-	-	-	3	2	-	-	-

Mapping of Course Outcomes with Program Specific Outcomes:

CO/PSO	PSO1	PSO2	PSO3
CO1	-	3	-
CO2	-	3	-
CO3	-	3	-
CO4	-	3	-
CO5	-	3	-

UNIT – I

Introduction to Digital Startup: Definition and types of startups-Digital startup ecosystem-The startup lifecycle-Identifying opportunities and ideation techniques-Role of innovation in digital startups-Case studies of successful digital startups

UNIT – II

Startup Capital Requirements and Legal Environment: Identifying Startup capital Resource requirements - estimating Startup cash requirements - Develop financial assumptions, constructing a Process Map - Positioning the venture in the value chain - Launch strategy to reduce risks- Startup financing metrics - The Legal Environment-Approval for New Venture Taxes or duties payable for new ventures

UNIT – III

Starting Up Financial Issues: Feasibility Analysis - The cost and process of raising capital – Unique funding issues of a high-tech ventures - Funding with Equity, Financing with Debt- Funding startups with bootstrapping- crowd funding- strategic alliances.

UNIT – IV

Start-Up Survival and Growth: Stages of growth in a new venture- Growing with the market - Growing within the industry- Venture life patterns- Reasons for new venture failures Scaling Ventures – preparing for change - Leadership succession, Support for

growth and sustainability of the venture.

UNIT – V

Planning for Harvest and Exit: Dealing with Failure: Bankruptcy, Exit Strategies Selling the business - Cashing out but staying in-being acquired- Going Public (IPO) – Liquidation.

Text Books:

1. Kathleen R Allen, Launching New Ventures, An Entrepreneurial Approach, Cengage Learning, ISBN-13:978-1305102507.
2. Anjan Raichaudhuri, Managing New Ventures Concepts and Cases, Prentice Hall International, ISBN-9788120341562.

Reference Books:

1. S. R. Bhowmik & M. Bhowmik, Entrepreneurship, New Age International, T. ISBN-13:9788122419061.
2. Steven Fisher, Ja-nae' Duane, The Startup Equation -A Visual Guidebook for Building Your Startup, Indian Edition, McGraw Hill Education India Pvt. Ltd. ISBN- 978-0071832366

Web Links:

1. https://onlinecourses.swayam2.ac.in/imb20_mg22/preview
2. <https://archive.nptel.ac.in/courses/110/106/110106141/>

Relevant cases have to be discussed in each unit and in examination case study is compulsory from any unit.

CONSUMER ANALYTICS

Course Code: 244MS072	L	T	P	C
	2	0	1	3

Course Outcomes:

At the end of the Course, Student will be able to:

- CO1:** Apply the key concepts of the marketing management process, linking them to consumer analytics and insights.
- CO2:** Analyze and design non-linear pricing strategies for profit maximization.
- CO3:** Make use of conjoint analysis techniques.
- CO4:** Measure consumer value using metrics.
- CO5:** Compare consumer analytics in various domains like advertising, retailing, and internet & social marketing.

Mapping of Course Outcomes with Program Outcomes:

CO/PO	PO1	PO2	PO3	PO4	PO5	PO6	PO7	PO8
CO1	-	3	-	2	-	-	-	-
CO2	-	3	-	2	-	-	-	-
CO3	-	3	-	2	-	-	-	-
CO4	-	3	-	2	-	-	-	-
CO5	-	3	-	2	-	-	-	-

Mapping of Course Outcomes with Program Specific Outcomes:

CO/PSO	PSO1	PSO2	PSO3
CO1	-	3	-
CO2	-	3	-
CO3	-	3	-
CO4	-	3	-
CO5	-	3	-

UNIT – I

Marketing Management and Consumer Analytics: The Marketing Management Process and its link to Consumer Analytics and Consumer Insights, Correlation, Simple linear regression, Trend, seasonality, Exponential smoothing.

UNIT – II

Pricing: Non-linear pricing strategies for profit maximization, price skimming and sales, optimal pricing, price bundling, demand curve and the willingness to pay.

UNIT – III

Consumer Insights: Conjoint analysis, product attributes and levels, full profile conjoint analysis, choice based conjoint analysis, random utility theory.

UNIT – IV

Consumer Value: Lifetime Consumer value, relation between spending, customer acquisition and customer retention, Market basket analysis, RFM analysis

UNIT – V

Market Segmentation: Cluster analysis, collaborative filtering and classification trees for segmentation, Application of Consumer Analytics in Advertising, Retailing and Internet & Social Marketing.

Text Books:

1. Consumer Behaviour and Analytics by Andrew Smith, 2020. Routledge Publications, ISBN-13:978-1138592650.
2. Damian Ryan. Understanding Digital Marketing: Marketing Strategies for Engaging the Digital Generation (3rd Edition). Kogan Page Publishers, ISBN-10:0749453893.

Reference Books:

1. Winston, Wayne L, Marketing Analytics: Data-Driven Techniques with Microsoft Excel, 1st ed. Wiley, ISBN-13:978-1118373439.
2. Vandana Ahuja. Digital Marketing. Oxford University Press India, ISBN-0136094236.

Web Links:

1. <https://archive.nptel.ac.in/courses/110/105/110105142/>
2. <https://www.coursera.org/learn/quantitative-customer-insights>

Relevant cases have to be discussed in each unit and in examination case study is compulsory from any unit.

E-MAIL MARKETING

Course Code: 244MS073	L	T	P	C
	3	0	0	3

Course Outcomes:

At the end of the Course, Student will be able to:

- CO1:** Explain the fundamental concepts, history, and the significance of email marketing.
- CO2:** Analyze the elements and strategies involved in organizing and managing mailing lists.
- CO3:** Develop compelling and effective email content, including newsletters and announcements.
- CO4:** Examine the benefits and strategies for email automation.
- CO5:** Apply techniques for tracking and analyzing email marketing performance.

Mapping of Course Outcomes with Program Outcomes:

CO/PO	PO1	PO2	PO3	PO4	PO5	PO6	PO7	PO8
CO1	-	2	-	-	-	-	-	-
CO2	-	2	-	-	-	-	-	-
CO3	-	2	-	-	-	-	-	-
CO4	-	2	-	-	-	-	-	-
CO5	-	2	-	-	-	-	-	-

Mapping of Course Outcomes with Program Specific Outcomes:

CO/PSO	PSO1	PSO2	PSO3
CO1	-	2	-
CO2	-	2	-
CO3	-	2	-
CO4	-	2	-
CO5	-	2	-

UNIT – I

Introduction to E-mail Marketing: Meaning, Importance, Email Marketing Goals, History of Email Marketing, Advantages and Disadvantages of Email Marketing and reasons for increase in email marketing. Popular Email Marketing Tools.

UNIT – II

Organizing the Mailing List: Mailing List elements and concepts, Developing E-mails to Drive Results, Critical Design Factors, Utilize and Optimization of Preheader, Headline, and Call-to-Action and Subject Lines. Subscriber List Management Strategies & related Issues.

UNIT – III

Email Content: Composing various types of e-mails, Newsletters and Announcements Using images & videos, how to write Effective content and subject line, Landing Pages- Meaning, design & Factors to be considered. Development of a Brand Strategy through E-mail Marketing and integration with other digital tools.

UNIT – IV

Automating Emails and Spam Compliance: Marketing Automation, Why Email automation is required, Designing an effective Email campaign, The Demonstrated Value of Automated Emails, Welcome e-mails. Date-Based Triggers, Action and Event Triggers. SPAM Testing and minimizing related complaints, Blacklisting.

UNIT – V

Analyzing and Tracking Email Marketing: Tracking Email Marketing Reports, Types of Tracking reports, Bounce Rates /Non-bounce rates, Open Rates & Click through rates. Tracking email data, Optimization of Call-to-action and Lead Capture.

Text Books:

1. Email Marketing in a Digital World: The Basics and Beyond by Jason Smith, ISBN-13:978-1606499924.
2. Hillstrom's Email Marketing Excellence by Kevin Hillstrom, ASIN-B00A0617WO

Reference Books:

1. The Rebel's Guide to Email Marketing: Grow Your List, Break the Rules, and Win By DJ Waldow, Jason Falls, ISBN-10:0789749696.
2. 300 Email Marketing Tips: Critical Advice and strategy to turn subscribers into buyers and grow a six-figure business by Meera Kothand, ISBN-101098935470.

Web Links:

1. <https://www.coursera.org/learn/think-outside-the-inbox>
2. <https://www.coursera.org/projects/mailchimp-build-email-marketing-campaign>

Relevant cases have to be discussed in each unit and in examination case study is compulsory from any unit.

MOBILE MARKETING

Course Code: 244MS074

L	T	P	C
3	0	0	3

Course Outcomes:

At the end of the Course, Student will be able to:

- CO1:** Explain the history, definition, scope, and importance of mobile marketing and mobile commerce.
- CO2:** Analyze different types of mobile applications.
- CO3:** Differentiate between various mobile payment methods.
- CO4:** Develop effective mobile marketing strategies.
- CO5:** Identify the major concerns related to privacy and security in mobile marketing.

Mapping of Course Outcomes with Program Outcomes:

CO/PO	PO1	PO2	PO3	PO4	PO5	PO6	PO7	PO8
CO1	-	2	-	-	-	-	-	-
CO2	-	2	-	-	-	-	-	-
CO3	-	2	-	-	-	-	-	-
CO4	-	2	-	-	-	-	-	-
CO5	-	2	-	-	-	-	-	-

Mapping of Course Outcomes with Program Specific Outcomes:

CO/PSO	PSO1	PSO2	PSO3
CO1	-	2	-
CO2	-	2	-
CO3	-	2	-
CO4	-	2	-
CO5	-	2	-

UNIT – I

Introduction to Mobile Marketing: History, Definition, Scope, and Importance of Mobile marketing. Mobile Commerce - Definition, History, Scope, Characteristics, Applications, attributes and benefits of M-commerce. Growth and Future Prospects of M-Commerce.

UNIT – II

Mobile Applications: Mobile apps- Meaning, types & Importance. Mobile Gaming concept, Scenario in India and Future scope of online gaming. Text Message Marketing, Mobile advertising, Concept, types, advantages and limitations, Features of a good Mobile Marketing programme.

UNIT – III

Mobile Payments and Mobile Entertainment: Mobile payments: Mobile wallets, mobile browser payments, in-app mobile payments and mobile or wireless credit card transfers. Mobile Payment Models, Mobile Payment Service Providers. Mobile entertainment: Definition, Indian Scenario, OTT platforms, Mobile TV and Live TV, Mobile music. Mobile banking- Features, types and benefits. Mobile FinTech.

UNIT – IV

Mobile Marketing Strategies: Mobile marketing vs. traditional marketing, Integration of traditional marketing with mobile marketing campaigns. Mobile marketing campaign- Planning, Implementation and Optimization. Mobile engagement.

UNIT – V

Privacy and Security in Mobile Marketing: Major concerns/issues related to privacy and security in mobile marketing. Challenges and Best Practices in Mobile Marketing. Future scope for mobile marketing.

Text Books:

1. Social media and Mobile Marketing, Puneet Singh Bhatia, Wiley, New Delhi
ISBN-13:978-8126578078
2. A Beginners Guide to Mobile Marketing, Molly Garris and Karen Mishra, Business Expert press, New York. ISBN: 978-1606498408

Reference Books:

1. Digital Marketing 2.0, Rushen Chahal, Prof. Jayanta Chakraborti, Himalaya Publication, India, ISBN-978-93-5299-414-4.
2. Go Mobile, Jeanne Hopkins, Jamie Turner, Wiley Publications, New Jersey, ISBN-1118167783.

Web Links:

1. <https://www.coursera.org/learn/mobile-marketing-optimization-tactics-and-analytics>
2. <https://www.udemy.com/course/how-to-create-grow-a-mobile-app-iphone-android-business/?couponCode=NVDIN35>

Relevant cases have to be discussed in each unit and in examination case study is compulsory from any unit.

SEARCH ENGINE OPTIMIZATION

	L	T	P	C
Course Code: 244MS075	3	0	0	3

Course Outcomes:

At the end of the Course, Student will be able to:

- CO1:** Explain the basic concepts and significance of search engine optimization (SEO).
- CO2:** Make use of different tools like Google Search Console for SEO analysis and issue resolution.
- CO3:** Discover the importance and influence factors of on-page SEO
- CO4:** Differentiate between ethical and unethical linking practices
- CO5:** Apply SEO techniques for blogs, content management systems, local search, and mobile search

Mapping of Course Outcomes with Program Outcomes:

CO/PO	PO1	PO2	PO3	PO4	PO5	PO6	PO7	PO8
CO1	-	2	-	-	-	-	-	-
CO2	-	2	-	-	-	-	-	-
CO3	-	2	-	-	-	-	-	-
CO4	-	-	-	2	-	-	-	-
CO5	-	2	-	-	-	-	-	-

Mapping of Course Outcomes with Program Specific Outcomes:

CO/PSO	PSO1	PSO2	PSO3
CO1	-	2	-
CO2	-	2	-
CO3	-	2	-
CO4	-	2	-
CO5	-	2	-

UNIT – I

Introduction to SEO: Concepts of search engine optimization (SEO), Relevance, Importance, Popularity, Trust, Authority, Search engines and directories, how search engines work, Crawlers, robots, spiders, Algorithms, Search engine indexing, Ranking, Directories, Website architecture, Static pages, Dynamic pages.

UNIT – II

Search Engine Friendliness and Specific Rankings: Page coding, managing spiders/robots, Crawlability, Rewriting pages, Subdomains, Alexa ranking, Image optimization, Google search console analysis, crawler issues, remove urls, sitemap submission

UNIT – III

On-page SEO: Importance, influence factors, Optimizing Web Page, Website Optimization, title, description and keyword tags, header tags, Anchor Text, Navigation Links, Contextual links, Canonical URLs, Page Nations, keyword research, meta tag optimization, SEO content optimization, sitemap creation submission, robots.txt

UNIT – IV

Off-page SEO: Importance, influence factors, Right and wrong ways to link, Reciprocal links, three-way links, purchased links, link networks, Redirected links, Link bait, Trust rank and worthless links, Quality directories Performing and Implementing SEO, SEO goals, and Commercial intent, Fixing broken links, Sitemaps, Useful directory links, complaining to search engines, How to address a copyright violation

UNIT – V

Web 2.0 and Other Important Considerations: Website ecosystem, Micro sites, RSS feeds, Blogosphere, social media, Google calendar, Press releases, SEO for blogs, SEO for content management systems, SEO for local search, SEO for mobile search, Measurements, Google API, SEO tools, Free tools, Research and resources, Google my business listing, Google places

Text Books:

- 1 Internet Marketing, Dave Chaffey, Fiona Ellis-Chadwick, Kevin Johnston, Richard Mayer, Pearson Education, ISBN-10:978027371740.
- 2 SEO For Dummies, by Peter Kent, 7th Edition, For Dummies, ISBN-13:978-1119579571.

Reference Books:

- 1 Online Marketing, Gerry T. Warner and Joe Wilson Schaefer, ISBN-13:978-1790528431.
- 2 Search Engine Optimization: An Hour a Day-Jennipegrappone, Gradiva Cousin-Wiley, ISBN-13:978-0471787532.

Web Links:

- 1 <https://www.coursera.org/learn/search-engine-optimization>
- 2 <https://www.coursera.org/specializations/seo>

Relevant cases have to be discussed in each unit and in examination case study is compulsory from any unit.

SOCIAL MEDIA MARKETING

Course Code: 244MS076	L	T	P	C
	3	0	0	3

Course Outcomes:

At the end of the Course, Student will be able to:

- CO1:** Explain the meaning and definition of digital and social media marketing.
- CO2:** Identify best practices and pitfalls in sharing content on social media and bookmarking websites.
- CO3:** Develop a social media strategy by setting goals, planning, and choosing appropriate strategies.
- CO4:** Perceive the use of major social media platforms like Facebook, LinkedIn, Twitter, and YouTube for marketing purposes.
- CO5:** Assess the role of social analytics in measuring social media performance.

Mapping of Course Outcomes with Program Outcomes:

CO/PO	PO1	PO2	PO3	PO4	PO5	PO6	PO7	PO8
CO1	2	-	-	-	-	-	-	-
CO2	-	-	-	-	2	-	-	-
CO3	-	-	-	-	2	-	-	-
CO4	-	-	-	-	2	-	-	-
CO5	-	2	-	-	-	-	-	-

Mapping of Course Outcomes with Program Specific Outcomes:

CO/PSO	PSO1	PSO2	PSO3
CO1	-	2	-
CO2	-	2	-
CO3	-	2	-
CO4	-	2	-
CO5	-	2	-

UNIT – I

Introduction to Social Media Marketing-Meaning-Definition-Types of Social Media Websites-Mobile Apps-Email- social media-Various Social Media Websites; Blogging-Types, Platforms.

UNIT – II

Social Media Management-Social Media and Target Audience-Sharing content on social media-Book marking websites; DO’s and Don’ts of social media.

UNIT – III

Social Media Strategy-Goals, Planning, Strategies, Monitoring Analysis; Tips of Social Media Marketing-Customization; Social Media Optimization; Social Media Promotion-paid advertising – other methods-social media ROI.

UNIT – IV

Social Media for Marketing -Facebook, LinkedIn, Twitter, YouTube. Establishing Relationship with customer’s social media.

UNIT – V

Social Analytics- Automation and social media- social media and other types of Marketing, Managing Tools of social media.

Text Books:

1. Social Media Marketing: Tracy L. Tuten (2021), ISBN-10:1529731984.
2. Social Media Marketing 1st Edition, Michael R. Solomon, Tracy Tuten - Pearson Education, ISBN-13:978-0132551793.

Reference Books:

1. Social media & Mobile Marketing: (Includes Online Worksheets), Puneet Singh Bhatia – Wiley, ISBN-13:978-8126578078.
2. Social Media Marketing, Kristina Lane - Lap Lambert Publishing, ISBN-9783330007062.

Web Links:

1. <https://www.coursera.org/learn/social-media-marketing-introduction>
2. <https://www.udemy.com/course/best-social-media-marketing-training-course/?couponCode=LETSLEARNNOWPP>

Relevant cases have to be discussed in each unit and in examination case study is compulsory from any unit.

CONTENT MARKETING

	L	T	P	C
Course Code: 244MS077	3	0	0	3

Course Outcomes:

At the end of the Course, Student will be able to:

- CO1:** Explain the definition, history, and evolution of content marketing.
- CO2:** Identify various tools of content marketing, such as blogs, social media, webinars, videos, newsletters, and podcast.
- CO3:** Develop the content marketing strategy.
- CO4:** Apply Content Management Systems (CMS).
- CO5:** Analyze content marketing strategies used in different sectors.

Mapping of Course Outcomes with Program Outcomes:

CO/PO	PO1	PO2	PO3	PO4	PO5	PO6	PO7	PO8
CO1	2	-	-	-	-	-	-	-
CO2	-	2	-	-	-	-	-	-
CO3	-	2	-	-	-	-	-	-
CO4	-	2	-	-	-	-	-	-
CO5	-	2	-	-	-	-	-	-

Mapping of Course Outcomes with Program Specific Outcomes:

CO/PSO	PSO1	PSO2	PSO3
CO1	-	2	-
CO2	-	2	-
CO3	-	2	-
CO4	-	2	-
CO5	-	2	-

UNIT – I

Introduction to Content Marketing: Definition, history, evolution, objectives, importance, role of content marketing in businesses. Challenges and opportunities.

UNIT – II

Tools of Content Marketing: Blogs, branch guide/folder, social media, Case study, Webinars, Video publications, articles, Newsletters, Mobile Apps, Info-graphic, e-book, Whitepapers, podcasts, audio publications, websites and E-mails. Merits and challenges in using these tools. Content marketing and online marketing, influencer marketing.

UNIT – III

Content Marketing Strategy: Definition, objectives, strategic plan, Analysis of Business and understanding customers, Content marketing mix, timelines, budget and optimizing and content, Role of SEO in content marketing.

UNIT – IV

Content Management: Definition, Phases, CMS, Distribution of Content, Strategies in content distribution - guest blogging, repurposing and republishing, Importance of content Management, Metrics to monitor content.

UNIT – V

Cases in Content Marketing: Content Strategies used in sectors like Automobile, Services, FMCG, Pharmaceuticals, Airline, Future Trends in Content Marketing.

Text Books:

1. Content Marketing Fundamentals- SeanR.Mitchell, Create space Independent Pub, ISBN-13:978-1503232556.
2. Managing Content Marketing: The Real-World Guide for Creating Passionate Subscribers to Your Brand-Robert Roseand Joe Pulizzi, CMI Books, Division of Z Squared Media, LLC, ISBN-13:978-0983330714.

Reference Books:

1. Digital Marketing MBA: Guiding Principles for Researching, Planning, and Managing a Marketing Strategy to Transform Your Business-David J Bradley, The Bradly BusinessGroup.2019, ISBN-10:17310158444.
2. Getting Digital Marketing Right-David J Bradley, Create space Independent Publishing Platform, ISBN-13:978-1507642245.

Web Links:

1. <https://www.coursera.org/learn/content-marketing>
2. <https://www.coursera.org/learn/digital-content-planning-and-management>

Relevant cases have to be discussed in each unit and in examination case study is compulsory from any unit.

AFFILIATE MARKETING AND GOOGLE ADSENSE

Course Code: 244MS078	L	T	P	C
	3	0	0	3

Course Outcomes:

At the end of the Course, Student will be able to:

- CO1:** Explain the history, definition, and mechanisms of affiliate marketing.
- CO2:** Identify different types of affiliate marketing.
- CO3:** Examine the process of setting up an affiliate marketing program.
- CO4:** Analyze the importance of keyword research.
- CO5:** Develop a Google Ads account by choosing appropriate campaign types and goals.

Mapping of Course Outcomes with Program Outcomes:

CO/PO	PO1	PO2	PO3	PO4	PO5	PO6	PO7	PO8
CO1	-	2	-	-	-	-	-	-
CO2	-	2	-	-	-	-	-	-
CO3	-	2	-	-	-	-	-	-
CO4	-	2	-	-	-	-	-	-
CO5	-	2	-	-	-	-	-	-

Mapping of Course Outcomes with Program Specific Outcomes:

CO/PSO	PSO1	PSO2	PSO3
CO1	-	2	-
CO2	-	2	-
CO3	-	2	-
CO4	-	2	-
CO5	-	2	-

UNIT – I

Fundamentals of Affiliate Marketing: History, Definition and working of affiliate marketing, parties involved in Affiliate Marketing, Pros and Cons of Affiliate Marketing, The basis of Affiliate Marketing, How Affiliate Marketing works, Affiliate Program payment methods, Cookies and Affiliates, Tiered Affiliate Marketing, Cross selling and up selling, Multi-tier marketing and commissions, List of affiliate marketing software

UNIT – II

Types of Affiliate Marketing - Search affiliates - Price comparison service website - Loyalty websites - Cause related and coupon websites - Content and niche market website - Personal weblogs and website syndicates - Email marketing and shopping directories - Registration or co-registration affiliates - File sharing affiliates.

UNIT – III

Setting Up Affiliate Marketing Program - How to attract affiliates-Hosting and implementing an affiliate program-Growing you're Affiliate Numbers. Setting up an affiliate program-Affiliate network service agreement-Data feeds and customer returns. Merchants/publisher management-Setting up an Affiliate Marketing Software-Affiliate program promotion and content pages, Screen Affiliates-Combating affiliate fraud.

UNIT – IV

Introduction to Google Ads: Introduction to Google Ads, Google Ads Terminology, The Role of Google Ads, Understanding the Google Network, How Paid Search Works, The Pillars of Google Ad Success, **Keyword Research:** Meaning of Keyword, Types of Keywords, Keyword Research Keyword Research Methodology, How to Choose the Right Keywords to Target.

UNIT – V

Creating a Google Ads Account: Campaign, Campaign Types, Campaign Goals, Naming Your Campaign, Choosing Campaign Types, Location, Targeting, Languages, Budget, Delivery Method, Bid Strategies: Manual vs. Automated, Keyword Match Types, Ad Creation, Ad Rank & Quality Score, Landing Pages, Conversion Tracking.

Text Books:

1. Affiliate Marketing: The Beginner's Step by Step Guide to Making Money Online with Affiliate Marketing by Kevin Ulaner, ISBN-10:1974108640.
2. AdSense Made Easy: What is Google AdSense, Linda Lewis 2020. ISBN: 9798685113528

Reference Books:

1. The Complete Guide to Affiliate Marketing on the Web- by Bruce C. Brown, ISBN-10:1601381255.
2. The Google AdSense Handbook, The Introductory Guide to the Web's Most Famous and Popular Advertising Programme: the Basics and Key Points to Know, By Stefano Calicchio: 2021, ISBN-13:9791220275965.

Web Links:

1. <https://www.udemy.com/course/free-affiliate-marketing-course-for-beginners/>
2. <https://www.coursera.org/projects/google-ads-beginner>

Relevant cases have to be discussed in each unit and in examination case study is compulsory from any unit.

SUSTAINABLE DEVELOPMENT FOR BUSINESS

Course Code:244AC001

L	T	P	C
2	0	0	0

Course Outcomes:

At the end of the Course, Student will be able to:

- CO1:** Explain the United Nations Sustainable Development Goals (UN-SDGs).
- CO2:** Apply various Economic, Socio-Political and Ecological aspects of Sustainable Development.
- CO3:** Analyze the relationship between natural resource utilization and sustainable development.
- CO4:** Analyze the Triple Bottom Line (3 BL) approach.
- CO5:** Determine the role of technology in supporting a sustainable future.

Mapping of Course Outcomes with Program Outcomes:

CO/PO	PO1	PO2	PO3	PO4	PO5	PO6	PO7	PO8
CO1	-	-	-	1	-	-	-	-
CO2	-	-	-	1	-	-	-	-
CO3	-	-	-	1	-	-	-	-
CO4	-	-	-	1	-	-	-	-
CO5	-	-	-	1	-	-	-	-

Mapping of Course Outcomes with Program Specific Outcomes:

CO/PSO	PSO1	PSO2	PSO3
CO1	2	-	-
CO2	2	-	-
CO3	2	-	-
CO4	2	-	-
CO5	2	-	-

UNIT – I

Introduction to Sustainable Development: Meaning, Definition, Historical background, Features and Principles of Sustainable Development, United Nations Sustainable Development Goals (UN-SDGs), Significance and Challenges of Sustainable Development, Sustainability as a key driver of Innovation.

UNIT – II

Aspects of Sustainability Development: Introduction to different aspects of Sustainability Development, Economic Aspects- Meaning, Ways of Achieving Economic Sustainability, Socio-Political Aspects – Meaning, Ways of Achieving Socio-Political Sustainability, Ecological (Environmental) Aspects – Meaning, Ways of Achieving Ecological Sustainability.

UNIT – III

Natural Resources and Sustainable Development: Meaning of Natural Resources, Importance of Natural Resources, Classification of Natural Resources, Natural Resources Utilization and Sustainable Development, Salient features of Environment Protection Act 1986, Water Act 1974, Air Act 1981, Salient features of Kyoto Protocol from Indian perspective.

UNIT – IV

Sustainable Strategies of Business: Need to adopt sustainable strategy, Triple- bottom line Approach – People, Planet & Profit (3 BL Approach), Various Strategies for Sustainable Development: Community Knowledge, Harness Technology, Innovative Practices, Co-Operation and Partnership, Green Organizations, Corporate Social Responsibility and Corporate Governance.

UNIT – V

New Perspectives Towards Sustainability: Role of technology in supporting sustainable future, Design of products and processes in creating circular business economy, Sustainable products and services and branding and marketing communication, Sustainability Marketing to enhance brand, Collaborations and Partnerships in sustainable development, Green Business Practices.

Text Books:

- 1 Introduction to Sustainable Development, Martin J.Ossewaarde, SAGE Publications Pvt Ltd First Edition, ISBN-8183617859.
- 2 Sustainable Economic Development & Environment, Raj Kumar SenKartikC.Roy, Atlatic Publishers & Distributors Pvt Ltd, ISBN-10:9788171566297.

Reference Books:

- 1 Corporate Sustainability, Social Responsibility and Environmental Management, Camilleri, Mark Anthony, Springer International Publishing AG, ISBN-10:3319836005.
- 2 Sustainable Futures – Imperatives for Managing Social Agenda, Dr. Bhaskar Chatterjee, NotionPress, ISBN-9789382447009.

Web Links:

- 1 https://onlinecourses.nptel.ac.in/noc21_mg94/preview
- 2 <http://www.iimb.ac.in/18th-podcast-series-sustainability-business>

Relevant cases have to be discussed in each unit and in examination case study is compulsory from any unit

CORPORATE READINESS-I

	L	T	P	C
Course Code: 244AC002	2	0	0	0

Course Outcomes:

At the end of the Course, Student will be able to:

- CO1:** Make use of online tools for networking and profile building
- CO2:** Develop personal interview and soft skills
- CO3:** Build effective note taking skills
- CO4:** Take part in Group discussion sessions.
- CO5:** Making and delivering presentations.

Mapping of Course Outcomes with Program Outcomes:

CO/PO	PO1	PO2	PO3	PO4	PO5	PO6	PO7	PO8
CO1	-	-	1	-	-	-	-	-
CO2	-	-	1	-	-	-	-	-
CO3	-	-	1	-	-	-	-	-
CO4	-	-	1	-	-	-	-	-
CO5	-	-	1	-	-	-	-	-

Mapping of Course Outcomes with Program Specific Outcomes:

CO/PSO	PSO1	PSO2	PSO3
CO1	1	-	-
CO2	1	-	-
CO3	1	-	-
CO4	1	-	-
CO5	1	-	-

UNIT – I

Use Online Tools to Get More Opportunities

Introduce Yourself Professionally:

what is an Elevator pitch

Create an elevator pitch to introduce yourself professionally.

Build Your Personal Brand:

what a personal brand is and why it is important

Elements of a strong personal brand

Ways to build your skills and knowledge, reputation, and values and personality to strengthen your brand

Importance of authenticity in building a personal brand

Online Profile Building:

Importance of a professional online presence

social media tools for professional success

social media netiquette

Unleash the Power of LinkedIn Networking:

Ways to use LinkedIn for career growth
LinkedIn for your job search
LinkedIn to build your personal brand and network with professionals

Mock GD Session

UNIT – II

Prepare for Personal Interview:

Complete Guide to the Interview Process:

Parts of an interview process
prepare an articulate personal message for interviews
Research industry, companies and interviewer-specific information
Align profiles to the role they are applying for.

Tips for What to do During the Interview:

Appropriate behaviors to adopt before and during an interview
Strategies for effectively navigating a telephonic interview.

What Do You Know About Where You Want to Go?

Key areas of industry awareness
Importance of industry awareness
Interview questions based on industry awareness

How to Ace a Behavioral Interview:

Small talk to set the tone before a formal discussion
Respond to behavioral interview questions,
respond to organization-specific questions using the
Mission-Product/service-culture framework.

How to Answer Competency Based Questions:

Character and competency-based questions
Character based questions on strengths and weaknesses
STAR framework to answer competency-based questions

How to Highlight Your Soft Skills:

Lecture Introduction and Lesson Objectives
Soft skills to highlight during an interview
Respond to questions about time management
Respond to questions about adaptability
Respond to questions about conflict management
Respond to questions about teamwork

Netiquette to Follow for Virtual Interviews and Meetings:

Lecture Introduction and Lesson Objectives
Appropriate netiquette behaviors
What is meant by netiquette

UNIT – III

Note Taking:

Effective Note Taking:

Lecture Introduction and Lesson Objectives
Importance of note-taking
Process of note-taking
Different strategies for taking notes
Workplace interactions that require note-taking
Online tools for note-taking

Recording Minutes of a Meeting:

Importance of recording minutes in meetings
Best Practices for Recording Minute: gathering necessary documents, creating a template, structuring minutes
Essential Elements of Meeting Minutes

Assessment III:

Quiz
Workbook
Individual Assignment

UNIT – IV

Group Discussions:

Cracking Group Discussions:

Group Discussions as a Format
Universal Rules for Group Discussions
Strategies to be Heard during Group Discussions
Building on Others' Information
Decorum and Behaviors to Ensure in Group Discussions
Practicing Yourself

Mock GD Sessions

UNIT – V

Make and Deliver a Presentation:

Using Presentations in a Workplace:
Lecture Introduction and Lesson Objectives
Use of presentations in a workplace
Microsoft PowerPoint Vs Google Slides

Make A Presentation: Planning & Research:

Lecture Introduction and Lesson Objectives
Steps for planning and delivering a presentation
Presentation and slide show

Make A Presentation: Structuring, Drafting and Designing:

Lecture Introduction and Lesson Objectives
what is a Company case study
Drafting a Company Case Study
Lecture Introduction and Lesson Objectives

Steps to follow to fact-check content
What editing and proofreading are
Avoiding plagiarism
Design principles while creating a presentation

Make A Presentation: Practicing As a Group/ Delivering

Lecture Introduction and Lesson Objectives
Strategies for preparing an impactful presentation
Nonverbal communication to enhance your presentation
Speaker notes to present confidently
Strategies for dealing with technical glitches

Text Books:

1. The Business Readiness Levels: Balance skills, manage risk and demonstrate progress with a simple venture benchmark by Mohaimin Chowdhury and Richie Ramsden, ASIN-B07V1VNMYR.
2. 5 Steps to crack Personal Interview: A complete guide to get your dream job by Saurav Bhowmik, ISBN-978-1643244334.

Reference Books:

1. GD Guide, To Excel in Group Discussion by Gyan Shankar, 2019, ISBN:9781797457413
2. Personal Interview Skills by Krishan Kumar ISBN: 978-8193823101

Web links:

1. <https://archive.nptel.ac.in/courses/109/104/109104031/>
2. <https://nptel.ac.in/courses/109105144>

Relevant cases have to be discussed in each unit and in examination case study is compulsory from any unit.

CORPORATE READINESS-II

Course Code: 244AC003	L	T	P	C
	2	0	0	0

Course Outcomes:

At the end of the Course, Student will be able to:

- CO1:** Apply MSPC, ESEF, STAR frameworks to answer questions in interview.
- CO2:** Develop confident body language
- CO3:** Build effective group discussion skills.
- CO4:** Analyze the importance of organizational culture and values
- CO5:** Develop time management, Multi-tasking, WLB and EQ skills

Mapping of Course Outcomes with Program Outcomes:

CO/PO	PO1	PO2	PO3	PO4	PO5	PO6	PO7	PO8
CO1	-	-	1	-	-	-	-	-
CO2	-	-	1	-	-	-	-	-
CO3	-	-	1	-	-	-	-	-
CO4	-	-	1	-	-	-	-	-
CO5	-	-	1	-	-	-	-	-

Mapping of Course Outcomes with Program Specific Outcomes:

CO/PSO	PSO1	PSO2	PSO3
CO1	1	-	-
CO2	1	-	-
CO3	1	-	-
CO4	1	-	-
CO5	1	-	-

UNIT – I

Practice Personal Interviews:

Mock Interview I:

Lecture Introduction and Lesson Objectives

Practice and prepare for behavioral and character-based questions

Apply the MSPC and ESEF frameworks to answer questions

★ Activity 1

★ Activity 2

Mock Interview II:

Lecture Introduction and Lesson Objectives

Practice and prepare for behavioral questions to highlight your soft skills

Apply the STAR framework to answer questions related to time management, adaptability, teamwork and conflict resolution

★ Activity 1

★ Activity 2

Mock Interview III:

Lecture Introduction and Lesson Objectives

Practice and prepare for curveball questions

Apply reasoning and critical thinking skills to answer whimsical, office situation and brain teaser questions

- ★ Activity 1
- ★ Activity 2

UNIT – II

Body Language:

What is Confident Body Language?

Lecture Introduction and Lesson Objectives
Importance of nonverbal communication
Adopt a confident body language

- ★ Activity 1
- ★ Activity 2

How to Appear Confident During Interviews

Lecture Introduction and Lesson Objectives
Do's and don'ts of body language during interviews
Soler framework to maintain good body language during interviews

- ★ Activity 1
- ★ Activity 2

The Importance of Grooming:

Lecture Introduction and Lesson Objectives
Essentials of personal grooming
How to be approachable in the workplace

- ★ Activity 1
- ★ Activity 2

UNIT – III

Stand Out in Group Discussions

How to Think in Group Discussions:

Lecture Introduction and Lesson Objectives
What a group discussion entails
Skills needed for an effective group discussion

- ★ Activity 1
- ★ Activity 2

How to Speak and Which Roles to Play in a Discussion:

Lecture Introduction and Lesson Objectives
Different roles of participants in a GD
Practice preparing for a GD

- ★ Activity 1
- ★ Activity 2

Tips and Tricks to Ace Group Discussions:

Lecture Introduction and Lesson Objectives
Types of Group Discussions (GDs)

Do's and don'ts of participating in GDs

Practice participating in GDs

★ Activity 1

★ Activity 2

Use The Rule of Three:

Lecture Introduction and Lesson Objectives

'Rule of 3' technique

Case Study: Steve Jobs

Rule of 3' to structure a powerful response

★ Activity 1

★ Activity 2

Avoid Thinking Traps:

Lecture Introduction and Lesson Objectives

Common thinking traps and their impact

Strategies to overcome thinking traps

★ Activity 1

★ Activity 2

Overcome the Fight-Flight:

Lecture Introduction and Lesson Objectives

The fight, flight or freeze response

Gibbs' Reflective Cycle

Action plan to overcome the fight, flight or freeze response

★ Activity 1

★ Activity 2

UNIT – IV

Understand Workplaces:

Organizational Culture and Values:

Lecture Introduction and Lesson Objectives

Organizational culture and its importance

Elements of organizational culture

Connection between organizational culture, values and behavior

★ Activity 1

★ Activity 2

Diversity and Inclusion:

Lecture Introduction and Lesson Objectives

Elements of diversity

Importance of diversity in the workplace

Strategies to adapt to diversity in the workplace

★ Activity 1

★ Activity 2

Situational Awareness:

Lecture Introduction and Lesson Objectives

Steps to follow in case of workplace discrimination

What discrimination and harassment in the workplace look like

★ Activity 1

★ Activity 2

Thinking like a leader:

Lecture Introduction and Lesson Objectives

Leadership

Theories of leadership

Personal leadership style

★ Activity 1

★ Activity 2

UNIT – V

Self-Management:

Time Management:

Lecture Introduction and Lesson Objectives

Online tools that can be used to apply different time management strategies

Different time management strategies and techniques

★ Activity 1

★ Activity 2

Multitasking and Productivity:

Lecture Introduction and Lesson Objectives

Multitasking and recognize the drawbacks of multitasking

Process of becoming a task opportunist

Ways to become task opportunist effectively

Different apps and tools to become a better task opportunist

★ Activity 1

★ Activity 2

Manage Stress to Improve Work-life Balance:

Lecture Introduction and Lesson Objectives

Signs of stress and identify triggers

Impact of stress on wellbeing

Action plan to ensure a healthy work-life balance

★ Activity 1

★ Activity 2

Improve EQ and Manage Emotions:

Lecture Introduction and Lesson Objectives

Meaning and importance of having high emotional quotient in the workplace

Differentiate between emotional quotient and intelligence quotient

How to foster healthy relationships in the workplace for stronger communication

★ Activity 1

★ Activity 2

Text Books:

1. The Business Readiness Levels: Balance skills, manage risk and demonstrate progress with a simple venture benchmark by Mohaimin Chowdhury and Richie Ramsden, ASIN-B07V1VNMYYR.
2. 5 Steps to crack Personal Interview: A complete guide to get your dream job by Saurav Bhowmik, ISBN-978-1643244334.

Reference Books:

1. GD Guide, To Excel in Group Discussion by Gyan Shankar, 2019,ISBN-13:978-1797457413.
2. Self-Awareness By Harvard Business Review, Daniel Goleman, Robert Steven Kaplan, Susan David, Tasha Eurich, ISBN:978-1633696617

Web links:

1. <https://archive.nptel.ac.in/courses/109/104/109104031/>
2. <https://nptel.ac.in/courses/109105144>

Relevant cases have to be discussed in each unit and in examination case study is compulsory from any unit.

CORPORATE READINESS-III

Course Code: 244AC004	L	T	P	C
	2	0	0	0

Course Outcomes:

At the end of the Course, Student will be able to:

- CO1:** Analyze the role team work and collaboration
- CO2:** Build trust, credibility and professional network.
- CO3:** Distinguish between different types of arguments.
- CO4:** Evaluate the role of emotional intelligence at work place.
- CO5:** Develop self-awareness and skill identification.

Mapping of Course Outcomes with Program Outcomes:

CO/PO	PO1	PO2	PO3	PO4	PO5	PO6	PO7	PO8
CO1	-	-	1	-	-	-	-	-
CO2	-	-	1	-	-	-	-	-
CO3	-	-	1	-	-	-	-	-
CO4	-	-	1	-	-	-	-	-
CO5	-	-	1	-	-	-	-	-

Mapping of Course Outcomes with Program Specific Outcomes:

CO/PSO	PSO1	PSO2	PSO3
CO1	1	-	-
CO2	1	-	-
CO3	1	-	-
CO4	1	-	-
CO5	1	-	-

UNIT – I

Understand Teamwork:

Teamwork:

Lecture Introduction and Lesson Objectives

Skills required for teamwork

Different roles people can play in a team

Importance of teamwork

★ Activity 1

★ Activity 2

Advanced Conflict Resolution Strategies:

Lecture Introduction and Lesson Objectives

Common workplace conflicts and identify the causes behind them

Role of collaboration in handling conflicts

Strategies for enabling collaboration

★ Activity 1

★ Activity 2

Collaborate With Others:

Lecture Introduction and Lesson Objectives

Conflict and its causes

Three approaches of handling conflict

★ Activity 1

★ Activity 2

Give And Receive Feedback:

Lecture Introduction and Lesson Objectives

Process of feedback

Giving constructive feedback

How to receive feedback positively

Create a development plan based on the feedback received

★ Activity 1

★ Activity 2

UNIT – II

Prepare for the Workplace:

Build Trust & Credibility:

Lecture Introduction and Lesson Objectives

Elements of trust

Self-assess and reflect on your own trustworthiness

Reflect on people you find trustworthy using the BRAVING framework

★ Activity 1

★ Activity 2

Build Your Professional Networks:

Lecture Introduction and Lesson Objectives

How professional networking helps in building trust

Practices to build trust

The seven-step process to mend broken trust

★ Activity 1

★ Activity 2

Learn The Art of Small Talk:

Lecture Introduction and Lesson Objectives

Importance of making small talk at the workplace

Strategies for making small talk meaningful

Techniques for overcoming your hesitation when initiating small talk

★ Activity 1

★ Activity 2

Practice Small Talk in Professional Spaces:

Lecture Introduction and Lesson Objectives

Small talk is and its benefits

Do's and don'ts for practicing small talk

Small talk in different professional spaces

★ Activity 1

MBA Curriculum-2024

★ Activity 2

UNIT – III

Logical Arguments:

Lecture Introduction and Lesson Objectives

Identify an argument and its parts

Structure sound arguments

Identify logical fallacies

Structure an argument by applying logic

★ Activity 1

★ Activity 2

Types of Arguments:

Lecture Introduction and Lesson Objectives

Deductive and inductive arguments in workplace scenarios

Written argument: a position, reasons, evidence, counter-argument

Situations where you have to use written arguments in the workplace and see examples of written arguments

★ Activity 1

★ Activity 2

Evidence and Biases:

Lecture Introduction and Lesson Objectives

Differentiate between facts and opinions

Strategies to avoid bias in written arguments

Authenticity of evidence

★ Activity 1

★ Activity 2

Critically Evaluating Arguments:

Lecture Introduction and Lesson Objectives

Differentiate between strong and weak arguments through a group activity

Untangle arguments using different techniques

Use effective argumentation techniques to build convincing skills

★ Activity 1

★ Activity 2

Overcoming Biases:

Lecture Introduction and Lesson Objectives

Biases and their effect on thinking

Internally held and externally experienced biases

Debiasing techniques to develop unbiased thinking

Responding appropriately to externally experienced biases

★ Activity 1

★ Activity 2

UNIT – IV

Emotional Intelligence:

Empathy at work:

Lecture Introduction and Lesson Objectives

What is empathy
Scenarios where you need to show empathy
Blockers to empathy
Showing empathy at the workplace
★ Activity 1
★ Activity 2

Compassion and gratitude:

Lecture Introduction and Lesson Objectives
Importance of showing compassion and discuss ways of demonstrating it
Differentiate between gratitude and appreciation and discuss the impact of both
Practice showing gratitude
★ Activity 1
★ Activity 2

UNIT – V

Self-Awareness:

Learning strategies:

Lecture Introduction and Lesson Objectives
Different types of intelligences
Learning styles and identify strategies that you can use to enhance your learning
Obstacles to learning and create a plan of action to enhance productivity
★ Activity 1
★ Activity 2

Self-awareness - skill identification:

Lecture Introduction and Lesson Objectives
Differentiate between emotional quotient and intelligence quotient and the impact of each of them
What it means to be self-aware
Johari Window Model to cultivate self-awareness
★ Activity 1
★ Activity 2

Motivating self and others:

Lecture Introduction and Lesson Objectives
Components of motivation
'BREAK' approach to improve your motivation
Importance of motivation and its theories
Differentiate between intrinsic and extrinsic motivation
★ Activity 1
★ Activity 2

Addressing an Audience with Confidence: Part 1

Lecture Introduction and Lesson Objectives
Purpose and importance of confidence
Ways to show confidence through body language
Practice Jam Session to boost confidence

★ Activity 1

★ Activity 2

Addressing an Audience with Confidence: Part 2

Lecture Introduction and Lesson Objectives

Purpose and importance of public speaking

Ways to address audience during public speaking

Practice public speaking through class activity

★ Activity 1

★ Activity 2

Text Books:

1. The Business Readiness Levels: Balance skills, manage risk and demonstrate progress with a simple venture benchmark by Mohaimin Chowdhury and Richie Ramsden, ASIN-B07V1VNMYR.
2. The Emotionally Intelligent Team: Building Collaborative Groups that Outperform the Rest by Vanessa Urch Druskat, ASIN-B0C9N3W9Q5

Reference Books:

1. Establishing Trust and Credibility by Timothy F. Bednarz , Majorium Business Press, ASIN: B00HRFZ93Y
2. Self-Awareness By Harvard Business Review, Daniel Goleman, Robert Steven Kaplan, Susan David, Tasha Eurich, ISBN: 978-1633696617

Web links:

1. https://onlinecourses.nptel.ac.in/noc23_mg123/preview
2. https://onlinecourses.nptel.ac.in/noc20_hs13/preview

Relevant cases have to be discussed in each unit and in examination case study is compulsory from any unit.

APTITUDE TRAINING

	L	T	P	C
Course Code: 244AC005	2	0	0	0

Course Outcomes:

At the end of the Course, Student will be able to:

- CO1:** Gain conceptual knowledge about the number system and Use mathematical concepts to calculate fractions, averages, and ratios.
- CO2:** Apply mathematical skills to interpret data and draw conclusions
- CO3:** Use mathematical and logical reasoning skills to solve problems efficiently
- CO4:** Use percentage shortcuts to calculate profit, loss, and interest
- CO5:** Practice advanced quantitative problem-solving to solve questions

Mapping of Course Outcomes with Program Outcomes:

CO/PO	PO1	PO2	PO3	PO4	PO5	PO6	PO7	PO8
CO1	-	2	-	-	-	-	-	-
CO2	-	2	-	-	-	-	-	-
CO3	-	2	-	-	-	-	-	-
CO4	-	2	-	-	-	-	-	-
CO5	-	2	-	-	-	-	-	-

Mapping of Course Outcomes with Program Specific Outcomes:

CO/PSO	PSO1	PSO2	PSO3
CO1	2	-	-
CO2	2	-	-
CO3	2	-	-
CO4	2	-	-
CO5	2	-	-

UNIT – I

Fundamentals of Mathematics:

Numerical Ability: Introduction to Number System, HCF, and LCM, Types of numbers, conversion of numbers, Prime factorization, Finding HCF and LCM using prime factorization, Euclid algorithm, word problems.

Number Series I: Basic number series, Basic arithmetic progression questions, Arithmetic and geometric progression, mixed series questions, Word problems based on both concepts

Fractions and Averages: Applications of averages in real-life scenarios, Types of fractions, Operations on Fractions, Conversion of fractions to decimals and percentages, Word problems involving fractions and averages

Ratio and Proportion: Compound ratio and combined ratio, Meaning of proportion, Word problems on ratios.

UNIT – II

Percentages, Profit and Loss, SI and CI:

Percentages: Converting percentages to fractions and decimals, Percentage increase and decrease, Application of percentages real-life scenarios.

Profit and Loss: Meaning of terms and formulae, Relationship between various variables, Discounts, Successive discount, Word problems. **Simple and Compound Interest:** Meaning of interest, the formula for SI and CI, Word problems.

UNIT – III

Data Interpretations, Permutation and Combination:

Data Interpretation I: Questions based on Bar graphs, line graphs, tables and pie chart.

Data Interpretation II: Double and triple bar graphs questions, Double pie chart questions, Questions based on profit and loss, and multiple tables.

Permutation and Combination: Finding the number of permutations of n objects taken r at a time, Circular permutation, Application of permutation in real-life scenarios, finding the number of combinations of n objects taken r at a time, Application of combination in real-life scenarios.

Probability: Meaning and formula of probability, questions based on coins, lottery tickets, cards.

UNIT – IV

Quantitative Problem Solving:

Time and Work: Inverse principle, word problems based on this topic.

Speed, Distance and Time: Inverse principle, word problems based on this topic, Relationship between speed, distance and time, Average speed and relative speed, Word problems based on train.

Boat and Streams, Train Problems: Relative speed, Upstream and downstream concept, Problems based on two trains.

Numerical Methods: Basic concepts of mixtures and alligations, Types of mixtures, Alligations method, Applications of this topic in real life, Word problems.

Pipes and Cisterns: Work done by pipes and cisterns, Pipes and cisterns problems involving filling and emptying the tank, Pipes and cisterns problems involving different rates of filling and emptying, Problems involving two or more pipes and cisterns working together.

UNIT – V

Mathematical Reasoning and Logical Reasoning:

Calendar: Leap year, day and date, repeated years, and exact day

Arithmetic Reasoning: Questions based on basic mathematical reasoning which includes the number of legs or heads, sharing between friends, number of routes.

Analogy and Odd One Out: Meaning of Analogy, Questions based on numbers and words, Meaning of odd one out, Questions based on words and numbers.

Directions and Coding-decoding: Direction graph, Questions based on Pythagoras theorem, angles, and shadow, Letter, number and substitution coding.

Coded Inequalities: Meaning of inequality, Statement and conclusion-based questions.

Blood Relations: Family tree, Coded blood relations, Questions based on photographs

Text Books:

1. Quantitative Aptitude for Competitive Examinations by RS Aggarwal, ISBN-13:978-9355012326.
2. Quantitative Aptitude for Competitive Examination by Abhijit Guha, ISBN-13:978-9389811544.

Reference Books:

1. Text Book of Quickest Mathematics: Quantitative Aptitude & Numerical Ability Useful for all Competitive Exams by Kiran Prakashan, ISBN-13:978-9390797363.
2. Quantitative Aptitude for Comprehension by Trisha Knowledge System, ISBN-13:978-9353063047.

Web Links:

1. <https://www.coursera.org/learn/quantitative-foundations-international-business>
2. <https://www.coursera.org/learn/mathematical-thinking>

AI IN BUSINESS

Course Code: 244AC006	L	T	P	C
	2	0	0	0

Course Outcomes:

At the end of the Course, Student will be able to:

- CO1:** Explain various AI tools and technologies available in the market
- CO2:** Analyse the application of AI in different industries such as retail, SCM, HR and sales
- CO3:** Assess the benefits and challenges of AI in different industries through case studies
- CO4:** Identify the role of AI in law enforcement and cyber security
- CO5:** Analyse the common ethical dilemmas arising from AI technologies

Mapping of Course Outcomes with Program Outcomes:

CO/PO	PO1	PO2	PO3	PO4	PO5	PO6	PO7	PO8
CO1	-	2	-	-	-	-	-	-
CO2	-	2	-	-	-	-	-	-
CO3	-	2	-	-	-	-	-	-
CO4	-	2	-	-	-	-	-	-
CO5	-	2	-	-	-	-	-	-

Mapping of Course Outcomes with Program Specific Outcomes:

CO/PSO	PSO1	PSO2	PSO3
CO1	2	-	-
CO2	2	-	-
CO3	2	-	-
CO4	2	-	-
CO5	2	-	-

UNIT – I

Introduction of Artificial Intelligence: Understanding of what Artificial Intelligence (AI) is and its importance in the modern world, Clear differentiation between Artificial Intelligence and Technology, Overview of various AI tools and technologies available in the market, Understanding the basics of AI through real-life examples

UNIT – II

AI in Different Industries: Application of AI in the retail industry through Amazon Go case study, AI in trading, investment advice, and risk management in Zerodha, role of AI in enhancing SCM operations in Delhivery, potential future applications of AI in SCM, specific AI tools and technologies being used in HR in HUL, benefits of AI in HR, Indian company using Ai in Marketing and Sales, Challenges of Implementation of AI in Companies

UNIT – III

AI in Customer Experience in Business: benefits and challenges of using AI in the food and beverage industry through Starbucks case study, AI tools are available for entrepreneurs to use, Validator AI, Naming Magic, Looka, Durable, MonkerAI, potential benefits and limitations of using AI tools in business, how to integrate AI tools into their business processes and workflows, data privacy and security considerations

UNIT – IV

AI in Virtual World: AI in Cyber security- Role of AI in law enforcement and cyber security, Types of AI tools and technologies to prevent cyber crimes, Future and challenges of AI in cyber security, Required skills and qualifications needed to work in cyber security with AI. **AI in E-Sports-** Basics of AI used in gaming, Creation of game strategies, predict game trends, and improve player performance, Types of AI systems used in gaming, such as machine learning algorithms and bots, Chess, ludo, and PUBG, Ethical considerations of using AI in gaming, Future developments in AI and gaming; virtual reality and augmented reality games, **AI Sports & Fitness:** Benefits of AI in sports and fitness, such as improved performance, reduced risk of injury, and faster recovery times through Catapult Sports case study, wearable sensors, motion analysis software, and machine learning algorithms. **AI in Robotics I:** Product Name: Sophia, Types of robots and their functionalities in real-life scenarios, Role of AI in science fiction and its influence on public perception of

AI, **AI in Robotics II:** Laparoscopy and NASA; AI robots in healthcare for tasks such as surgical procedures, patient monitoring, and medication management, room service, concierge services, and customer service, AI robots in space exploration for tasks such as satellite repair, maintenance, and exploration, **AI in Entertainment:** AI in various stages of content creation, including scriptwriting, voice synthesis, and visual effects. AI-powered tools and platforms used in content creation, such as Lumen5, ScriptBook, and AIVA

UNIT – V

AI Chat Pro: Productivity through AI; ChatGPT, Use ChatGPT to write assignments, prepare for interviews, resume building, The Ethical Dilemma of AI: common ethical dilemmas arising from AI technologies, the impact of AI on society, privacy, bias, accountability, and job displacement, roles of policymakers, developers, and users in ensuring ethical AI practices, emerging trends, such as explainable AI and AI governance frameworks, to promote transparency and accountability

Text Books:

1. Artificial Intelligence: A Modern Approach by Stuart Russel and Peter Norvig, ISBN-14:978-9356063570.
2. Life 3.0: Being Human in the Age of Artificial Intelligence by Max Tegmark, ISBN-10:9780141981802.

Reference Books:

1. Deep Learning Illustrated: A Visual, Interactive Guide to Artificial Intelligence by John Krohn, Grant Beyleveld, and Aglae Bass, ISBN-10:0135116694.
2. Applied Artificial Intelligence in Business: Concepts and Cases by Leong Chan, Liliya Hogaboam, Renzhi Cao, 21 July 2023, Springer International Publishing, ISBN-978-3031057403

Web Links:

1. <https://nptel.ac.in/courses/106102220>
2. https://onlinecourses.nptel.ac.in/noc22_cs56/preview

DESIGN THINKING AND INNOVATION

	L	T	P	C
Course Code: 244AC007	2	0	0	0

Course Outcomes:

At the end of the Course, Student will be able to:

- CO1:** Explain the core concepts and historical evolution of Design Thinking.
- CO2:** Apply empathy research methods to gather user insights and create problem statements and journey maps.
- CO3:** Analyze ideation techniques and develop prototypes using various tools.
- CO4:** Evaluate user feedback and implement iterative design improvements.
- CO5:** Examine the principles and processes of innovation and differentiate between types of innovation.

Mapping of Course Outcomes with Program Outcomes:

CO/PO	PO1	PO2	PO3	PO4	PO5	PO6	PO7	PO8
CO1	-	2	-	-	-	-	-	-
CO2	-	2	-	-	-	-	-	-
CO3	-	2	-	-	-	-	-	-
CO4	-	2	-	-	-	-	-	-
CO5	-	2	-	-	-	-	-	-

Mapping of Course Outcomes with Program Specific Outcomes:

CO/PSO	PSO1	PSO2	PSO3
CO1	2	-	-
CO2	2	-	-
CO3	2	-	-
CO4	2	-	-
CO5	2	-	-

UNIT – I

Design Thinking: Definition, Historical background and evolution, Benefits, Applications of Design Thinking; The Design Thinking Process (Empathize, Define, Ideate, Prototype, and Test), Cultivating creativity, empathy, and problem-solving skills.

UNIT – II

Empathy Research Methods: Interviews, observations, and user personas, Understanding User Needs: Techniques for gathering and analyzing user insights.

Problem Definition: Framing and articulating the problem statement. Journey Mapping: Visualizing user experiences and identifying pain points. (Tools and Techniques: Empathy maps, user journey maps, and personas.)

UNIT – III

Ideation Techniques: Brainstorming, mind mapping, SCAMPER, and role-playing. Encouraging Creativity: Techniques to foster an innovative mindset.

Prototyping Methods: Low-fidelity and high-fidelity prototypes, wireframes, and mock-ups. Rapid Prototyping: Iterative development and testing of prototypes. (Tools and Resources: Prototyping tools and software; e.g., Sketch, InVision, Figma)

UNIT – IV

User Testing Methods: Usability testing, A/B testing, and feedback loops. Gathering and Analyzing Feedback: Techniques for collecting and interpreting user feedback. Iterative Design: Refining solutions based on user feedback and testing results.

Implementation Strategies: Planning and executing the rollout of new solutions.

UNIT – V

Innovation: -Meaning, Concept, Characteristics, Importance, Principles of Innovation, Process of Innovation, Factors Influencing Innovation, Types of innovation (incremental, disruptive, open, and radical)

Text Books:

1. Gavin Ambrose, Paul Harris, “Basics Design - 8: Design Thinking”, illustrated, reprint, AVA Publishing, ISBN-10:2940411174.
2. Christian Müller-Roterberg, “Handbook of Design Thinking”, Kindle Direct Publishing ISBN: 978-1790435371.

Reference Books:

1. Innovation Management by C S G Krishnamacharyulu & Lalitha R, Himalaya Publishing House, ISBN-978-93-5097-920-4.
2. Vinnie Jauhari, Sudanshu Bhushan, Innovation Management, Oxford Higher Education, ISBN-978-0198080985.

Web Links:

1. https://onlinecourses.nptel.ac.in/noc22_mg32/preview
2. https://onlinecourses.swayam2.ac.in/imb23_mg65/preview

BUSINESS MANAGEMENT TOOLS

Course Code: 244AC008	L	T	P	C
	2	0	0	0

Course Outcomes:

At the end of the Course, Student will be able to:

- CO1:** Utilize business management tools effectively to improve organizational efficiency.
- CO2:** Develop proficiency in using G-Suite applications for streamlined collaboration and productivity.
- CO3:** Manage documents and PDFs efficiently to enhance document organization and accessibility.
- CO4:** Enhance productivity through the use of Excel shortcuts and advanced functions for data analysis.
- CO5:** Gain practical knowledge in SQL fundamentals and Power BI for effective data retrieval and visualization in business intelligence.

Mapping of Course Outcomes with Program Outcomes:

CO/PO	PO1	PO2	PO3	PO4	PO5	PO6	PO7	PO8
CO1	-	2	-	-	-	-	-	-
CO2	-	2	-	-	-	-	-	-
CO3	-	2	-	-	-	-	-	-
CO4	-	2	-	-	-	-	-	-
CO5	-	2	-	-	-	-	-	-

Mapping of Course Outcomes with Program Specific Outcomes:

CO/PSO	PSO1	PSO2	PSO3
CO1	-	2	-
CO2	-	2	-
CO3	-	2	-
CO4	-	2	-
CO5	-	2	-

UNIT – I

Introduction to Business Management Tools: Business Management Tools- Types of business management tools, relevance of business management tools in modern business operations
Role of business management tools to improve productivity, efficiency, and decision-making in organizations

Adobe Tools: Overview of Adobe tools, Applications of Adobe tools, key features and functionalities of Adobe tools

Microsoft Suite: Overview of Microsoft Suite, including Microsoft Word, Microsoft Excel, Microsoft PowerPoint, and Microsoft Outlook, Capabilities of Microsoft Suite for business functions.

UNIT – II

G-Suite: G-Suite Essentials- Introduction to G-Suite and its various applications, G-Suite tools, sending invites, setting out of office, and managing calendars

Document Management with Google Docs: Creating and formatting documents using Google Docs, features in Google Docs, formatting techniques and working with pre-set templates

Creating Presentations with Google Slides: Introduction to Google Slides and its features, designing effective presentations using Google Slides, formatting slides and utilizing pre-set templates

Data Management with Google Spreadsheets: Overview of Google Spreadsheets and its functionalities, Data entry, manipulation, and basic formulas in Google Spreadsheets, Last mile formatting and advanced features of Google Spreadsheets

UNIT – III

Document and PDF Management: Merging and Compressing PDFs- Process of merging multiple PDFs into a single, Document, Techniques for compressing PDF files to reduce file size, Merging and compressing PDFs using various tools

Editing PDFs: Introduction to PDF editing tools and software, editing text, images, and other elements in PDF documents, Editing PDFs and annotating documents

UNIT – IV

Excel Shortcuts and Advanced Functions: Excel Shortcuts for Business Management- Essential Excel shortcuts for improved productivity, Time-saving techniques and tips for navigating Excel efficiently, Applying Excel shortcuts to common business management tasks

Advanced Excel Functions for Data Analysis: Introduction to advanced Excel functions for data analysis, using functions such as VLOOKUP, SUMIF, and COUNTIF, Applying advanced Excel functions to analyze business data

UNIT – V

SQL Fundamentals: Introduction to SQL- Basics of Structured Query Language (SQL), Creating and manipulating databases and tables, Writing SQL queries for data retrieval and manipulation

Power BI: Overview of Power BI and its role in business intelligence, connecting to data sources and creating visualizations, designing interactive dashboards using Power BI

Text Books:

1. "The Lean Startup: How Today's Entrepreneurs Use Continuous Innovation to Create Radically Successful Businesses" by Eric Ries, ISBN-13:978-0670921607.
2. "Good to Great: Why Some Companies Make the Leap...And Others Don't" by Jim Collins, ISBN-10:0712676090

Reference Books:

1. "The Innovator's Dilemma: When New Technologies Cause Great Firms to Fail" by Clayton M. Christensen, ISBN-10:142219602X.
2. "Technology management in business"- by Avinash Pawar, Nitin Zaware and Kuldip Charak, ISBN-10:1925823024.

Web Links:

1. <https://nptel.ac.in/courses/110105083>
2. <https://archive.nptel.ac.in/courses/110/106/110106157/>

INTELLECTUAL PROPERTY RIGHTS

Course Code: 244AC009

L T P C
2 0 0 0

Course Outcomes:

At the end of the Course, Student will be able to:

- CO1:** Compare different IP laws and need for protecting IP
- CO2:** Explain different theories on the concept of property
- CO3:** Identify various functions of WIPO
- CO4:** Analyze the IP laws in India
- CO5:** Differentiate various forms of IPR

Mapping of Course Outcomes with Program Outcomes:

CO/PO	PO1	PO2	PO3	PO4	PO5	PO6	PO7	PO8
CO1	1	-	-	-	-	-	-	-
CO2	1	-	-	-	-	-	-	-
CO3	1	-	-	-	-	-	-	-
CO4	1	-	-	-	-	-	-	-
CO5	1	-	-	-	-	-	-	-

Mapping of Course Outcomes with Program Specific Outcomes:

CO/PSO	PSO1	PSO2	PSO3
CO1	1	-	-
CO2	1	-	-
CO3	1	-	-
CO4	1	-	-
CO5	1	-	-

UNIT – I

Introduction: Origin and Development of IPR – Historical and theoretical basis for protection of IPR – Analyzing and understanding the Interpretation of IP laws – Need for Protecting IP

UNIT – II

Concept of Property: Theories on concept of property – Nature – Public Vs. Private – Tangible Vs. Intangible – Industrial Vs. Intellectual

UNIT – III

International IP Regime: World Intellectual Property Organization (WIPO) – Functions of WIPO – Membership – GATT Agreement – Major Conventions on IP – Berne Convention – Paris Convention – TRIPS agreement.

UNIT – IV

Indian IP Regime: Overview of IP laws in India – Major IP Laws in India – International treaties signed by India. IPR and Constitution of India.

UNIT – V

Forms of IPR: Forms of IPR – Copyright – Trademark – Patents – Industrial Designs – Trade Secrets – Geographical Indications - Application of different forms of IPR.

Text Books:

- 1 International Encyclopaedia of Laws: Intellectual Property (Kluwer Law International) (looseleaf). I,MON K 1401, ISBN-978-9065449443.
- 2 E. K.Ahuja, Law relating to Intellectual Property rights, 2 nd Edition, LexisNexis, F. ISBN-13:978-8131251652.

Reference Books:

- 1 Barrett, Margreth, Intellectual Property,3rd, New York Aspen publishers, ISBN-13:978-0735578883.
- 2 Nard, Craig Allen, Law of Intellectual Property, 2 nd, New York Aspen publishers, ISBN-13:978-0735579156.

Web Links:

- 1 https://onlinecourses.nptel.ac.in/noc22_hs59/preview
- 2 <https://archive.nptel.ac.in/courses/110/105/110105139/>

Relevant cases have to be discussed in each unit and in examination case study is compulsory from any unit.

PROJECT MANAGEMENT

Course Code: 244AC010	L	T	P	C
	2	0	0	0

Course Outcomes:

At the end of the Course, Student will be able to:

- CO1:** Explain the basic concepts of project Management
- CO2:** Estimate project planning and risk.
- CO3:** Interpret project financing through techniques
- CO4:** Analyze the concept of Project controlling
- CO5:** Summarize stress management, conflict management and team building

Mapping of Course Outcomes with Program Outcomes:

CO/PO	PO1	PO2	PO3	PO4	PO5	PO6	PO7	PO8
CO1	-	1	-	-	-	-	-	-
CO2	-	1	-	-	-	-	-	-
CO3	-	1	-	-	-	-	-	-
CO4	-	1	-	-	-	-	-	-
CO5	-	1	-	-	-	-	-	-

Mapping of Course Outcomes with Program Specific Outcomes:

CO/PSO	PSO1	PSO2	PSO3
CO1	-	1	-
CO2	-	1	-
CO3	-	1	-
CO4	-	1	-
CO5	-	1	-

UNIT – I

Introduction to Project Management: Project Characteristics – Project Life Cycle – Project Identification, Formulation and Implementation – Project Management in Different Sectors: Construction, Services Sector, Public Sector and Government Projects. Systems Approach to Project Management.

UNIT – II

Project Appraisal: Project Planning – Steps in Project Planning – Scheduling – Project Appraisal – Feasibility Study – Technical, Commercial, Economic, Financial, Management, Social Cost Benefit Analysis – Project Risk Analysis

UNIT – III

Project Finance: Project Cost Estimation, Project Financing – Investment Criteria, Project Evaluation Techniques – Pay Back Period, Accounting Rate of Return, Net Present Value, Internal Rate of Return, Profitability Index, Cash Flows Estimation for New and Replacement Projects – Cost of Capital, Risk Analysis.

UNIT – IV

Project Control: Network Diagrams, Network Analysis, Critical Path, Quality Management, Project Execution, Monitoring and Control, Agile Project Management, Scrum, Lean Production and Project Management.

UNIT – V

Organizational Behavior and Project Management: Organizational Structure and Integration, Role of Project Manager, Roles in the Project Team, Project Stakeholder Engagement, Leadership in Project Management, Participative Management, Team Building Approach, Conflict Management in Projects, Stress Management.

Text Books:

1. Clifford F. Grey, Erik W. Larson, Gautam V. Desai “Project Management The Managerial Process” Tata Mcgraw Hill, Fourth Edition, ISBN-13:978-9339212032.
2. Pinto K. J. Project Management Pearson Education Second Edition, ISBN-13:978-9389552034.

Reference Books:

1. John M. Nicholas “Project Management for Business and technology “Pearson Education Second edition, ISBN-978-0-7506-8399-9.
2. Kerzner Harold, “Project Management: A System Approach to Planning, Scheduling, and Controlling” CBS Publishers & Distributors, New Delhi, Second Edition, ISBN-13:978-1119165354.

Web Links:

1. https://onlinecourses.nptel.ac.in/noc23_mg124/preview
2. https://onlinecourses.nptel.ac.in/noc24_mg01/preview

Relevant cases have to be discussed in each unit and in examination case study is compulsory from any unit.

EMPLOYABILITY SKILLS- I**Course Code: 244AC011**

L	T	P	C
0	0	3	0

Aptitude:

Number System, LCM & HCF, Ratio and Proportion, Averages

Reasoning:

Number Series, Letter Series, Number Analogy, Letter Analogy, Odd Man Out, Logical Sequence of Words.

Verbal:

Introduction to soft skills, how to improve communication? Parts of Speech, Mind your language towards better English, Vocabulary Expansion

Text Books:

1. Quantitative Aptitude for Competitive Examinations - Dr. R. S. Aggarwal, S. Chand Publishing, ISBN: 978-9352534029
2. A Modern Approach to Verbal and Non-Verbal Reasoning - Dr. R. S. Aggarwal, Publication: S. Chand Publishing, ISBN: 978-9352832163

Reference Books:

1. Quick Learning Objective General English - Dr. R. S. Aggarwal, Vikas Aggarwal, S. Chand Publishing, ISBN: 978-9352837564
2. Quantitative Aptitude for Competitive Examinations, Abhijit Guha, McGraw Hill Education, ISBN: 978-9353160180
3. Analytical Reasoning - M. K. Pandey, Arihant Publications, ISBN: 978-9350947982

Web Links:

1. www.indiabix.com
2. www.bankersadda.com

EMPLOYABILITY SKILLS- II

Course Code: 244AC012

L	T	P	C
0	0	3	0

Aptitude:

Problems on Ages, Partnership, Percentages, Profit and Loss

Reasoning:

Coding and Decoding, Ranking Test, Alphabet Test, Direction Test

Verbal:

Written communication skill practice, Grammatical use, Concept of 4 step method for presentation, Present Tense

Text Books:

1. Quantitative Aptitude for Competitive Examinations - Dr. R. S. Aggarwal, S. Chand Publishing, ISBN: 978-9352534029
2. A Modern Approach to Verbal and Non-Verbal Reasoning - Dr. R. S. Aggarwal, Publication: S. Chand Publishing, ISBN: 978-9352832163

Reference Books:

1. Quick Learning Objective General English - Dr. R. S. Aggarwal, Vikas Aggarwal, S. Chand Publishing, ISBN: 978-9352837564
2. Quantitative Aptitude for Competitive Examinations, Abhijit Guha, McGraw Hill Education, ISBN: 978-9353160180
3. Analytical Reasoning - M. K. Pandey, Arihant Publications, ISBN: 978-9350947982

Web Links:

1. www.indiabix.com
2. www.bankersadda.com

EMPLOYABILITY SKILLS- III**Course Code: 244AC013**

L	T	P	C
0	0	3	0

Aptitude:

Simple Interest, Compound Interest, Time and Work, Pipes and Cisterns

Reasoning:

Blood Relations, Calendar, Clocks, Cubes and Dice, Coded Inequalities

Verbal:

Grammar in use, Group discussion, Reading Comprehension, Past Tense, Future Tense

Text Books:

1. Quantitative Aptitude for Competitive Examinations - Dr. R. S. Aggarwal, S. Chand Publishing, ISBN: 978-9352534029
2. A Modern Approach to Verbal and Non-Verbal Reasoning - Dr. R. S. Aggarwal, Publication: S. Chand Publishing, ISBN: 978-9352832163

Reference Books:

1. Quick Learning Objective General English - Dr. R. S. Aggarwal, Vikas Aggarwal, S. Chand Publishing, ISBN: 978-9352837564
2. Quantitative Aptitude for Competitive Examinations, Abhijit Guha, McGraw Hill Education, ISBN: 978-9353160180
3. Analytical Reasoning - M. K. Pandey, Arihant Publications, ISBN: 978-9350947982

Web Links:

1. www.indiabix.com
2. www.bankersadda.com