

PROGRAM CURRICULUM

STRUCTURAL ENGINEERING

for

M. TECH. TWO YEAR DEGREE PROGRAM

(Applicable for the batches admitted from A.Y 2024-25)



ADITYA UNIVERSITY

Aditya Nagar, ADB Road, Surampalem - 533 437

VISION & MISSION OF THE UNIVERSITY

VISION :

Aditya University aspires to be a globally recognised academic institution dedicated to quality education, cutting-edge research, and technological service to our country, and envisions itself as a beacon of holistic advancement and long-term impact, remaining dynamic in the ever-changing worlds of society, ecology, and economics..

MISSION:

- Aditya University pushes boundaries to design high-quality curricula and to provide students with a vibrant and relevant education that prepares them for a changing world. Our industry insights and creative teaching methods attempt to equip our students to be lifelong learners.
- Aditya University's learning environment encourages intellectual curiosity, critical thinking, and cooperation, with the goal of providing students with an immersive education that fosters creativity and innovation. Our cutting-edge facilities, interactive classrooms, and supportive faculty aim to motivate students to realise their full potential and contribute to society.
- Aditya University promotes cross-disciplinary inquiry and discovery and leads cutting-edge research and innovation. Through strategic partnerships, research grants, and a dedicated faculty, we aim to advance science, technology, and social sciences and empower students and faculty to conduct transformative research that solves real-world problems and elevates our institution globally.
- Aditya University is committed to producing world-changing business leaders and entrepreneurs through its emphasis on entrepreneurship, mentoring, and business incubation programmes.

DEPARTMENT OF CIVIL ENGINEERING

VISION:

To excel in academics, consultancy, and research in Civil Engineering and addressing global challenges for the sustainable development of society.

MISSION:

- M1:** To deliver outstanding education in Civil Engineering through top-notch teaching, cutting- edge facilities, and dynamic mentorship
- M2:** To cultivate Civil Engineering graduates who excel professionally, tackle complex technical challenges with creativity, and demonstrate leadership, ethics, and social responsibility.
- M3:** To advance interdisciplinary and sustainable research and development to meet the evolving and demanding needs of future built infrastructure.
- M4:** To instill entrepreneurial thinking in students through industrial interaction, empowering them to become ethical leaders in the civil engineering profession.

PROGRAM OUTCOMES (POs)

After successful completion of the program, the graduates will be able to

PO1:	An ability to independently carry out research /investigation and development work to solve practical problems
PO2:	An ability to write and present a substantial technical report/document
PO3:	Students should be able to demonstrate a degree of mastery over the area as per the specialization of the program. The mastery should be at a level higher than the requirements in the appropriate bachelor program
PO4:	Change management skills and the ability to learn, keep up with contemporary technologies and ways of working.
PO5:	Function and communicate effectively as an individual or a team leader in diverse and multidisciplinary groups. Use methodologies such as agile.
PO6:	Use the principles of project management such as scheduling, work breakdown structure and be conversant with the principles of Finance for profitable project management.

PROGRAM SPECIFIC OUTCOMES (PSO's)

After successful completion of the program, the graduates will be able to

PSO 1	Analyze complex structural engineering problems and apply independent judgment to solve them.
PSO 2	Conduct research and contribute individually/in group (s) to the development of scientific/technological knowledge in one or more domains of structural engineering.

PROGRAM EDUCATIONAL OBJECTIVES (PEOs)

Graduates of the Program will

PEO 1	Deliver high-quality education in structural engineering, equipping students to address technological demands and socio-economic challenges effectively.
PEO 2	Cultivate design skills in students, enabling them to innovate, develop, and implement solutions that drive economic growth and enhance quality of life.
PEO 3	Engage in life-long learning and excel to their profession for the betterment of society and environment.



Department of Civil Engineering

Master of Technology in Structural Engineering

Program Curriculum - 2024

Credit Division:

S.No.	Category of Course	Credits
1	Program Core Courses (PCC)	30
2	Program Elective Courses (PEC)	15
3	University Elective Courses (UEC)	03
4	Summer Internship (SI)	02
5	Technical Paper Publication (TPP)	02
6	Project Part-I & II (PROJ)	28
7	Audit Courses (AUC)	0
Total Credits		80

Program Core Courses (PCC):

Course Code	Course Title	L	T	P	C	CIE	SEE	Total	Pre-requisite
242CE001	Advanced Mathematical Methods	4	0	0	4	50	50	100	-
242CE002	Theory of Elasticity	3	0	0	3	50	50	100	-
242CE003	Theory of Plates and Shells	4	0	0	4	50	50	100	TE
242CE004	Advanced Concrete Technology	3	0	2	5	50	50	100	-
242CE005	Advanced Reinforced Concrete Design	4	0	2	6	50	50	100	-
242CE006	Finite Element Methods	4	0	0	4	50	50	100	-
242CE007	Computer-Aided Design Laboratory	0	0	2	2	50	50	100	FEM
242CE008	Structural Engineering Laboratory	0	0	2	2	50	50	100	-
Total		22	0	8	30				

Program Elective Courses (PEC):

Course Code	Course Title	L	T	P	C	CIE	SEE	Total	Pre-requisite
242CE009	Matrix Analysis of Structures	3	0	0	3	50	50	100	-
242CE010	Structural Dynamics	3	0	0	3	50	50	100	
242CE011	Stability of Structures	3	0	0	3	50	50	100	SD
242CE012	Experimental Techniques and Instrumentations	3	0	0	3	50	50	100	-
242CE013	Analytical & Numerical Methods for Structural Engineering	3	0	0	3	50	50	100	AMM
242CE014	Design of Foundations	3	0	0	3	50	50	100	CDP
242CE015	Bridge Engineering	3	0	0	3	50	50	100	DF
242CE016	Structural Audits	3	0	0	3	50	50	100	-
242CE017	Analysis of Offshore Structures	3	0	0	3	50	50	100	-
242CE018	Earthquake Resistant Design of Buildings	3	0	0	3	50	50	100	SDIF
242CE019	Precast and Prefabricated Structures	3	0	0	3	50	50	100	
242CE020	Earth Retaining Structures	3	0	0	3	50	50	100	ERDS
242CE021	Design of Pre-stressed Concrete structures	3	0	0	3	50	50	100	PPS
242CE022	Structural Health Monitoring	3	0	0	3	50	50	100	-
242CE023	Soil Structure Interaction	3	0	0	3	50	50	100	ANSE

University Elective Courses (UEC):

Course Code	Course Name	L	T	P	C	CIE	SEE	Total	Offered to PG Program
242CE028	Metro Rail Transportation Design and Construction (L&T EduTech) **	3	0	0	3	50	50	100	All, except SE
242CE029	Building Information Modelling in Architecture, Engineering and Construction (L&T EduTech) **	3	0	0	3	50	50	100	All, except SE
242CE030	Basic Concrete Technology	3	0	0	3	50	50	100	All, except SE
242CE031	Repair & Rehabilitation of Structures	3	0	0	3	50	50	100	All, except SE
242EE028	Neural Networks and Fuzzy Logic	3	0	0	3	50	50	100	All, except PED
242EE029	Hybrid Electric Vehicles	3	0	0	3	50	50	100	All, except PED
242EE030	Electrical Power Distribution and Automation (L&T EduTech) **	3	0	0	3	50	50	100	All, except PED
242EE031	Renewable Energy & Power Evacuation (L&T EduTech) **	3	0	0	3	50	50	100	All, except PED
242ME028	Design of fire and life safety systems (L&T Edu Tech) **	3	0	0	3	50	50	100	All, except TE
242ME029	Green Engineering Systems	3	0	0	3	50	50	100	All, except TE
242ME030	I.C. Engines	3	0	0	3	50	50	100	All, except TE
242EC028	CAD Tools for VLSI Design	3	0	0	3	50	50	100	All, except VLSID
242EC029	FPGA Design for Embedded Systems	3	0	0	3	50	50	100	All, except VLSID
242CS030	Artificial Intelligence	3	0	0	3	50	50	100	All, except CSE

242CS031	Machine Learning Techniques	3	0	0	3	50	50	100	All, except CSE
----------	-----------------------------	---	---	---	---	----	----	-----	-----------------

**The syllabus for the industry partner courses will be released in the department as and when required

Summer Internship (SI)

Course Code	Course Title	L	T	P	C	CIE	SIE	Total	Pre-requisite
242CE024	Summer Internship	0	0	2	2	100	-	100	-

Technical Paper Publication (TPP)

Course Code	Course Title	L	T	P	C	CIE	SIE	Total	Pre-requisite
242CE026	Technical Paper Publication	0	0	2	2	100	-	100	-

Project (PROJ)

Course Code	Course Title	L	T	P	C	CIE	SIE	Total	Pre-requisite
242CE025	Project part-I	0	0	10	10	100	-	100	-
242CE027	Project part-II	0	0	18	18	50	50	100	-

Audit Courses (AUC)

Course Code	Course Title	L	T	P	C	CIE	SIE	Total	Pre-requisite
242AC001	Value Education	2	0	0	0	100	-	100	-
242AC002	Research Methodology	2	0	0	0	100	-	100	-

2024 M.Tech (SE) CURRICULUM PRE-REQUISITE FLOW CHART

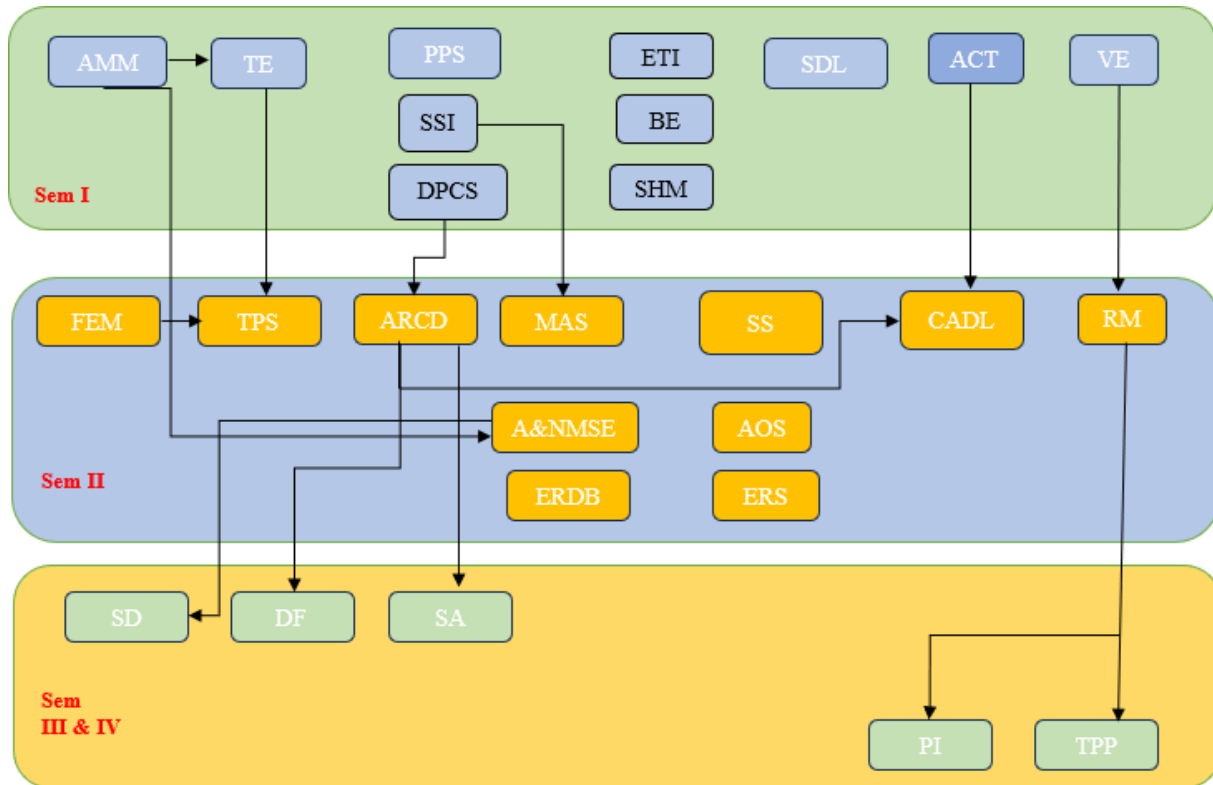

AMM	Advanced Mathematical Methods
TE	Theory of Elasticity
TPS	Theory of Plates and Shells
ACT	Advanced Concrete Technology
ASE	Advanced Structural Engineering
SD	Structural Dynamics
CADL	Computer Aided Design Laboratory
SDL	Structural Engineering Laboratory
FEM	Finite Elements Methods
MAS	Matrix Analysis of Structures
ARCD	Advanced Reinforced Concrete Design
SS	Stability of Structures
ETI	Experimental Techniques and Instrumentations
A&NMSE	Analytical & Numerical Methods for Structural Engineering

AOS	Analysis of Offshore Structures
ERDB	Earthquake Resistant Design of Buildings
PPS	Precast and Prefabricated Structures
ERS	Earth Retaining Structures
DPCS	Design of Pre-stressed Concrete structures
SHM	Structural Health Monitoring
SSI	Soil Structure Interaction
TPP	Technical Paper Publication
PROJ	Project Part - I and Project Part - II
RM	Research Methodology
VE	Value Education
SI	Summer Internship
DF	Design of Foundations
BE	Bridge Engineering
SA	Structural Audits

**Suggestive Semester Wise Curriculum
I Semester**

Course code	Course Title	Course	Credits				Total Hours
		Category	L	T	P	C	
242CE001	Advanced Mathematical Methods	PCC	4	0	0	4	4
242CE002	Theory of Elasticity	PCC	3	0	0	3	3
----	Program Elective Course-I	PEC	3	0	0	3	3
----	Program Elective Course-II	PEC	3	0	0	3	3
242CE004	Advanced Concrete Technology	PCC	3	0	2	5	7
242CE008	Structural Engineering Laboratory	PCC	0	0	2	2	4
242AC001	Value Education	AUC	2	0	0	0	2
Total			16	0	4	20	27

II Semester

Course code	Course Title	Course	Credits				Total Hours
		Category	L	T	P	C	
242CE003	Theory of Plates and Shells	PCC	4	0	0	4	4
242CE005	Advanced Reinforced Concrete Design	PCC	4	0	2	6	8
242CE006	Finite Element Methods	PCC	4	0	0	4	4
----	Program Elective Course-III	PEC	3	0	0	3	3
----	Program Elective Course-IV	PEC	3	0	0	3	3
242CE007	Computer-Aided Design Laboratory	PCC	0	0	2	2	4

242AC002	Research Methodology	AUC	2	0	0	0	2
Total			18	0	4	22	28

III Semester

Course code	Course Title	Course Category	Credits				Total Hours
			L	T	P	C	
----	Program Elective Course-V	PEC	3	0	0	3	3
----	University Elective Course	UEC	3	0	0	3	3
242CE024	Summer Internship	SI			2	2	3
242CE025	Project Part-I	PROJ	0	0	10	10	18
Total			6	0	12	18	30

IV Semester

Course code	Course Title	Course Category	Credits				Total Hours
			L	T	P	C	
242CE026	Technical Paper Publication	TPP	0	0	2	2	6
242CE027	Project Part-II	PROJ	0	0	18	18	34
Total					20	20	40

Program Elective Courses

Program Elective Course -I		
S.No	Course code	Course name
1	242CE021	Design of Pre-stressed Concrete structures
2	242CE023	Soil Structure Interaction
3	242CE019	Precast and Prefabricated Structures
Program Elective Course -III		
S.No	Course code	Course name
1	242CE009	Matrix Analysis of Structures
2	242CE013	Analytical & Numerical Methods for Structural Engineering
3	242CE018	Earthquake Resistant Design of Buildings
Program Elective Course -V		
S.No	Course code	Course name
1	242CE010	Structural Dynamics
2	242CE014	Design of Foundations
3	242CE016	Structural Audits

Program Elective Course -II		
S.No	Course code	Course name
1	242CE012	Experimental Techniques and Instrumentations
2	242CE015	Bridge Engineering
3	242CE022	Structural Health Monitoring
Program Elective Course -IV		
S.No	Course code	Course name
1	242CE011	Stability of Structures
2	242CE017	Analysis of Offshore Structures
3	242CE020	Earth Retaining Structures

ADVANCED MATHEMATICAL METHODS

Course Code: 242CE001

L	T	P	C
4	0	0	4

Course Outcomes:

At the end of the Course, Student will be able to:

- CO 1: Distinguish and analyse a variety of tools for solving linear systems and finding eigenvalues of these systems.
- CO 2: Derive and use the numerical techniques needed for the solution of a given engineering problems
- CO 3: Understand and correlate the analytical and numerical methods
- CO 4: Demonstrate their ability to write coherent mathematical proofs and scientific arguments needed to communicate the results obtained from differential equation models.
- CO 5: Demonstrate the understanding of how physical phenomena are modelled by partial differential equations

Mapping of course outcomes with program outcomes:

CO/PO	PO1	PO2	PO3	PO4	PO5	PO6
CO1	2	-	1	-	2	-
CO2	2	-	1	-	2	-
CO3	2	-	1	-	2	-
CO4	2	-	1	-	2	-
CO5	2	-	1	-	2	-

Mapping of course outcomes with program Specific Outcomes:

CO/PSO	PSO1	PSO2
CO1	-	-
CO2	-	-
CO3	-	-
CO4	-	-
CO5	-	-

UNIT – I

Eigenvalue Problems:

Standard Eigen value problems–Eigenvalues and Eigenvectors– Gerschgorin Circles theorem– Rutishauser method, Power method, Inverse Power method.

Iteration Methods:

Sturm sequence, Jacobi method, Given's method, Householder method, Deflation, Lanco's method

UNIT – II

Calculus of Variations:

Euler-Lagrange's equation –Isoperimetric problems, Rayleigh–Ritz method - Galerkin method.

UNIT – III

System of First Order Ordinary Differential Equations:

Linear Systems - Homogeneous linear systems with constant coefficients - Autonomous systems - Phase Plane Phenomena - Critical Points - Stability for linear systems.

Nonlinear systems:

Simple critical points of nonlinear systems-Stability by Liapunov's method – Non- Linear Mechanics: Conservative systems.

UNIT-IV

Partial Differential Equations:

Classification of Second-Order Partial Differential Equations, Significance of characteristic curves, Canonical Form, Sturm–Liouville problems and Eigen function expansions.

UNIT-V

Wave Equation:

Displacements in a long string – a long string under its weight – a bar with prescribed force on one end – free vibrations of a string. Method of Separation of variables, Solution by method of Laplace transforms.

Text Books:

1. Numerical Methods for Scientific and Engineering Computation, M. K. Jain, S. R. K. Iyengar, R. K. Jain, New Age International publishers, 7th edition, New Delhi. (Topics from Chapter 3, 7) **ISBN-13:** 978-9386649222
2. Introductory Methods of Numerical Analysis, S. S. Sastry, PHI Pvt. Ltd., 5th Edition, New Delhi. (Topics from Chapter 11) **ISBN-13:** 978-8120345928

Reference Books:

1. Differential Equations and Dynamical Systems, Lawrence Perko, 3rd ed., Springer- Verlag. **ISBN-13:** 978-0387951164
2. An introduction to Ordinary Differential Equations, James C. Robinson, Cambridge University Press, New York (4th print). **ISBN-13:** 978-0521533911

3. Numerical Analysis, R. L. Burden and J. D. Faires, 10th Edition, Cengage Learning, India edition. **ISBN-13:** 978-8131518739

Web Links:

1. www.onlinecourses.nptel.ac.in/noc23_ma33/preview
2. www.archive.nptel.ac.in/courses/112/104/112104035/

THEORY OF ELASTICITY

Course Code: 242CE002

L	T	P	C
3	0	0	3

Course Outcomes:

At the end of the Course, Student will be able to:

- CO 1: Explain the theory of elasticity including strain / displacement and hooke’s law relationships.
- CO 2: Apply Fourier series for two dimensional problems for gravity loading
- CO 3: Develop general equations for two dimensional problems in polar coordinates
- CO 4: Determine principal stress and shear stress using general theorems.
- CO 5: Develop solutions for torsional problems by energy method.

Mapping of course outcomes with program outcomes:

CO/PO	PO1	PO2	PO3	PO4	PO5	PO6
CO1	3	-	3	-	-	-
CO2	3	-	3	-	-	-
CO3	3	-	3	-	-	-
CO4	3	-	3	-	-	-
CO5	3	-	3	-	-	-

Mapping of course outcomes with program Specific Outcomes:

CO/PSO	PSO1	PSO2
CO1	-	1
CO2	2	-
CO3	2	1
CO4	2	1
CO5	1	2

UNIT – I

Elasticity – notation for forces and stresses:

Components of stresses and strains – Hooke’s Law- Plane Stress – Plane strain – Differential Equations of equilibrium – Boundary conditions – Compatibility equations - Stress function – Boundary Conditions.

UNIT – II

Two dimensional problems in rectangular co-ordinates:

Solution by polynomials – Saint Venant’s principle – Determination of displacements – Bending of simple beams – Application of Fourier series for two dimensional problems for gravity loading.

UNIT – III

Two dimensional problems in polar co-ordinates:

General equations in polar co- ordinates – Stress distribution for problems having symmetrical about an axis - Strain components in polar co-ordinates–Displacements for symmetrical stress distributions - Stresses for plates with circular holes subjected to far field tension – stress concentration factor.

UNIT-IV

Analysis of stress and strain in three dimensions:

Principal stresses – Stress ellipsoid and stress director surface – Determination of principal stresses - Maximum shear stress – Homogeneous Deformation – General Theorems -Differential equations of equilibrium – Conditions of compatibility– Equations of equilibrium in terms of displacements – Principle of superposition – Uniqueness of solution –Reciprocal theorem

UNIT-V

Torsion of prismatical bars:

Bars with elliptical cross section – Other elementary solution – Membrane analogy – Torsion of rectangular bars – Solution of Torsional problems by energy method.

Text Books:

1. Theory of Elasticity- Stephen Timoshenko & J. N. Goodier, Mc.Grawhill Publishers, 3rd edition. **ISBN-13:** 978-0070858053
2. Elasticity: Theory, Applications and Numerics- Martin H. Sadd, Wiley Publishers, 3rd edition. **ISBN-13:** 978-0124081369

Reference Books:

1. Theory of elasticity, S.Singh, Khanna publications, standard edition.
ISBN-13: 978-8174092305
2. Theory of elasticity, L.D.Landau, E.M.Liftshitz, Cbs Publishers & Distributors, 3rd Edition. **ISBN-13:** 978-0750626330

Web Links:

1. <http://nptel.ac.in/courses/105108070/>
2. <http://www.sciencedirect.com/science/book/9780080570693>

THEORY OF PLATES AND SHELLS

Course Code: 242CE003

L	T	P	C
4	0	0	4

Course Outcomes:

At the end of the Course, Student will be able to:

- CO 1: Knowledge about various plate theories due to bending
- CO 2: Knowledge of Navier’s solution, Levy’s solution and solve for the rectangular and square plates
- CO 3: Analyse circular plates with various boundary conditions.
- CO 4: Focus on the finite difference method of solving shell problems.
- CO 5: Analyse cylindrical shells with the help of codal provisions.
- CO 6: Design of beams, Paraboloid shapes by beam and membrane theory.

Mapping of course outcomes with program outcomes:

CO/PO	PO1	PO2	PO3	PO4	PO5	PO6
CO1	2	-	2	-	1	-
CO2	1	2	2	-	1	-
CO3	1	2	2	-	1	-
CO4	1	2	2	-	1	-
CO5	2	3	2	-	1	-
CO6	1	-	2	-	1	-

Mapping of course outcomes with program specific outcomes:

	CO/PSO	PSO1	PSO2
	CO1	1	-
	CO2	1	-
	CO3	2	-
	CO4	2	-
	CO5	3	1
	CO6	3	1

UNIT-I

Introduction:

Derivation of governing differential equation for plate– in plane bending and transverse bending effects- Rectangular plates: Plates under various loading conditions like concentrated, uniformly distributed load and hydrostatic pressure. Navier and Levy’s type of solutions for various

boundary conditions.

UNIT-II

Circular plates:

Symmetrically loaded, circular plates under various loading conditions, Annular plates.

UNIT-III

Introduction to Shells:

Single and double curvature- Equations of Equilibrium of Shells. Derivation of stress resultants, Principles of membrane theory and bending theory.

UNIT-IV

Cylindrical Shells:

Derivation of the governing DKJ equation for bending theory, Details of Schorer's theory. Application to the analysis and design of short and long shells. Use of ASCE Manual coefficients for the design.

UNIT-V

Beam theory of cylindrical shells:

Beam and arch action. Design of diaphragms - Geometry analysis and design of elliptic Paraboloid, Conoidal and Hyperbolic Paraboloid shapes by membrane theory.

Text Books:

1. Theory of Plates and Shells 2e –S. Timoshenko and S. Woinowsky Krieger, McGraw-Hill book company, INC, New York. **ISBN-13:** 978-0070858206
2. Reinforced Concrete Shells and Folded Plates by P.C. Varghese, Prentice Hall India Publications **ISBN-13:** 978-8120327870
3. Analysis of thin concrete shells by K. Chandrasekhara, New age international (P) Ltd. **ISBN-13:** 978-8122411256

Reference Books:

1. Theory and Analysis of Elastic Plates and Shells by J. N. Reddy, CRS Press. **ISBN-13:** 978-0849384165
2. A Text Book of Shell Analysis – Bairagi, K, Khanna Publisher, New Delhi. **ISBN-13:** 978-8174090363
3. Design and Construction of Concrete Shell Roofs – Ramaswamy, G.S, Mc Graw Hill, Newyork. **ISBN-13:** 978-0070511583

Web Links:

1. <https://ocw.mit.edu/courses/mechanical-engineering/2-081j-plates-and-shells-spring-2007/readings/lecturenote.pdf>
2. <http://www.nptel.ac.in/courses/105105041/module%206.pdf>

ADVANCED CONCRETE TECHNOLOGY

Course Code: 242CE004

L	T	P	C
3	0	2	5

Course Outcomes:

At the end of the Course, Student will be able to:

- CO 1: Explain various concrete making materials.
- CO 2: Apply the concepts of workability characteristics and durability testing on concrete.
- CO 3: Interpret various design principles and properties of high strength concrete
- CO 4: Design special concrete and mix design using BIS Method – IS.10262 – 2019
- CO 5: Illustrate assembling and disassembling principles of formwork materials

Mapping of course outcomes with program outcomes:

CO/PO	PO1	PO2	PO3	PO4	PO5	PO6
CO1	-	1	3	-	-	-
CO2	1	2	1	-	-	-
CO3	-	1	-	-	-	-
CO4	1	2	1	-	-	-
CO5	-	1	-	-	-	-

Mapping of course outcomes with program specific outcomes:

CO/PSO	PSO1	PSO2
CO1	1	-
CO2	2	-
CO3	1	-
CO4	2	-
CO5	1	-

UNIT I

Concrete making materials:

Cement, Types of cement – OPC, PPC, GGBFS – Grades of Cement, 33, 43 & 53– Bogue's Compounds–Hydration Process–Types of Cement – Aggregates – Gradation Charts – Combined Aggregate – Alkali Silica Reaction – Admixtures – Chemical and Mineral Admixtures. Bureau of Indian Standards (BIS) Provisions.

Practice:

1. Study of variation of Coarse Aggregate to Fine Aggregates on Workability.
2. Study of variation of Coarse Aggregate to Fine Aggregates on Strength.

UNIT-II

Properties of concrete:

Fresh Concrete: workability tests on Concrete–Setting Times of Fresh Concrete – Segregation and bleeding. Hardened concrete: Abrams Law, Gel space ratios, Maturity concept–Stress strain Behaviour – Creep and Shrinkage – Non Destructive Testing of Concrete. BIS Provisions. Durability of concrete: Factors affecting strength of concrete and Durability of concrete – Cracks in concrete – Chemical attacks carbonation.

Practice:

1. Non destructive testing- Impact Hammer test, UPV test.

UNIT-III

High strength concrete:

Microstructure – Manufacturing and Properties – Design of HSC Using Erin Troy Shakklok method – Ultra High Strength Concrete.
High Performance Concrete – Requirements and Properties of High Performance Concrete – Design Considerations. BIS Provisions.

Practice:

1. Study on Water / Cement Ratios Vs Workability of different concretes.
2. Study on Water / Cement Ratios Vs Strength of different concretes.

UNIT-IV

Special concretes:

Self Compacting Concrete, Polymer Concrete, Fibre Reinforced Concrete–Reactive Powder Concrete – Requirements and Guidelines – Advantages and Applications. Vacuum dewatering of concrete–Under water concreting

Concrete mix design:

Quality Control–Quality Assurance–Quality Audit - Mix Design Method – BIS Method – IS.10262 – 2019 Concrete Mix proportion guidelines. DOE Method– Light Weight Concrete, Self Compacting Concrete.

Practice:

1. Qualifications tests on Self compaction concrete- L Box, J Box, U box and Slump tests.

UNIT-V

Form work:

Materials – structural requests – form work systems – connections – specifications – design of form work – shores – removal for forms - shores – reshoring – failure of form work.

Text Books:

1. Concrete: Micro Structure, Properties and Materials by P. K. Mehta and P. J. Monteiro, Mc. Graw-Hill Publishing Company Ltd. New Delhi. **ISBN-13:** 978-0071797870
2. Concrete Technology by M.S. Shetty, S.Chand & Co. **ISBN-13:** 978-8121900034

Reference Books:

1. Concrete Technology by A. R. Santhakumar, 2nd Edition, Oxford University Press.
ISBN-13: 978-0195671537
2. Design of Concrete Mixes by N. Krishna Raju, CBS Publications. **ISBN-13:** 978-8123913629

Web Links:

1. <https://archive.org/details/gov.in.is.10262.2019>
2. <https://www.scribd.com/document/533895848/Is-516-Part-1-Sec-I-2021-Compressive-Flexural-and-Split-Tensile-Strength>.
3. <https://archive.nptel.ac.in/courses/105/102/105102012/>
4. <https://www.nachi.org/constituent-materials-concrete.htm>
5. <https://elearn.nptel.ac.in/shop/nptel/advanced-concrete-technology/?v=c86ee0d9d7ed>

ADVANCED REINFORCED CONCRETE DESIGN

Course Code: 242CE005

L T P C
4 0 2 6

Course Outcomes:

At the end of the Course, Student will be able to:

- CO 1 : Understand and apply limit state method of design.
- CO 2 : Analyze yield line criteria of different types of slabs.
- CO 3 : Design flat slabs and ribbed slabs.
- CO 4 : Design of deep beams, corbels and nibs.
- CO 5: Design of slender columns

Mapping of Course Outcomes with Program Outcomes

CO/PO	PO1	PO2	PO3	PO4	PO5	PO6
CO1	2	2	2	2	2	-
CO2	2	-	2	1	1	-
CO3	3	2	2	-	2	-
CO4	3	2	2	-	2	-
CO5	3	2	2	-	2	-

Mapping of Course Outcomes with Program Specific Outcomes

CO/PSO	PSO1	PSO2
CO1	1	-
CO2	3	1
CO3	3	1
CO4	3	1
CO5	2	1

UNIT – I

Limit analysis of R C structures:

Rotation of a plastic hinge, Redistribution of moments, moment rotation characteristics of RC member, I.S. code provisions, loading pattern, Bending Moment Envelop, Application for Fixed Beams and Continuous Beams. Inelastic Analysis of Slabs, Moment Redistribution.

Practice:

1. Calculation of Young's Modulus of Elasticity of Concrete.

UNIT – II

Yield line analysis for slabs:

Yield line criterion – Virtual work and equilibrium methods of analysis – For square circular, Rectangular, Triangular and Hexagonal with simple and continuous end conditions.

Practice:

1. Study on Deflection and Cracks on a Under Reinforced Over Reinforced and Balanced Sections.
2. Study on Performance of RCC Beams designed for Bending and failing in Shear.
3. Study on Performance of RCC Beams designed for Shear and failing in Bending.

UNIT-III

Ribbed slabs:

Analysis of the Slabs for Moment and Shears, Ultimate Moment of Resistance, Design for shear, Deflection, Arrangement of Reinforcements.

Flat slabs:

Direct design method – Distribution of moments in column strips and middle strip-moment and shear transfer from slabs to columns – Shear in Flat slabs-Check for one way and two way shears-Introduction to Equivalent frame method. Limitations of Direct design method, Distribution of moments in column strips and middle strip sketch showing reinforcement details.

Practice:

1. Study on Performance of RCC one way slabs.
2. Study on Performance of RCC two way slabs with simply supported edge conditions.
3. Study on Performance of RCC two way slabs with fixed edge conditions.

UNIT-IV

Design of reinforced concrete deep beams & corbels:

Steps of Designing Deep Beams, Design by IS 456. Checking for Local Failures, Detailing of Deep Beams, Analysis of Forces in a Corbels, Design of Procedure of Corbels, Design of Nibs. Detailing of reinforcement.

UNIT-V

Design of slender columns:

Slenderness limits, Methods of Design of Slender Columns, Additional Moment Method, Procedure for Design of Slender Columns. Detailing of reinforcement. Eccentrically loaded columns, Development of interaction Diagrams.

Text Books:

1. Reinforced Concrete Structures, S. Unnikrishna Pillai & Devdas Menon, Tata McGraw Hill, New Delhi, 2017. **ISBN-13:** 978-9354601026.
2. Design of Reinforced Concrete Structures, N. Subrahmanyian, Oxford press publications, 2014. **ISBN-13:** 978-0198086949.
3. Limit State Design, A. K. Jain, Firewall Media Publishers, 2012. **ISBN-13:** 978-9361597817.

Reference Books:

1. Design of concrete structures, Arthus H. Nilson, David Darwin, and Chorles W. Dolar, Tata McGraw-Hill, 2020. **ISBN-13:** 978-1259002547.
2. Reinforced Concrete Structures, Park and Pauley, John Wiley, and Sons Publishers, 1975. **ISBN-13:** 978-0471659174.
3. Design of Reinforced Concrete Structures, Krishna Raju, New Age International, 2015. **ISBN-13:** 978-8123909899.

Web Links:

1. <https://nptel.ac.in/courses/111107105>
2. <https://nptel.ac.in/courses/111105041>
3. <https://nptel.ac.in/courses/111105090>

FINITE ELEMENT METHODS

Course Code: 242CE006

L	T	P	C
4	0	0	4

Course Outcomes:

At the end of the Course, Student will be able to:

- CO 1: Detailed knowledge and understanding of the fundamental concepts of finite element methods
- CO 2: Understanding of variation principles and approximation methods including Rayleigh- Ritz and weighted residual methods
- CO 3: Develop and assemble stiffness matrices for beam elements under varying loads.
- CO 4: Application of Finite Element Methods to plane stress, plane strain and axisymmetric problems.
- CO 5: Analyse bar and plane elements by iso- parametric formulation techniques and understanding and applying Gauss quadrature for numerical integration
- CO 6: Identify and mitigate the element and mesh instabilities

Mapping of course outcomes with program outcomes:

CO/PO	PO1	PO2	PO3	PO4	PO5	PO6
CO1	1	2	-	-	-	-
CO2	1	3	-	-	-	-
CO3	1	2	-	-	-	-
CO4	2	3	-	-	-	-
CO5	2	3	-	-	-	-
CO6	2	3	-	-	-	-

Mapping of course outcomes with program Specific Outcomes:

CO / PSO	PSO 1	PSO 2
CO1	1	-
CO2	2	-
CO3	2	-
CO4	3	-
CO5	3	-
CO6	3	-

UNIT-I

Introduction:

Review of stiffness method- Principle of Stationary potential energy-Potential energy of an elastic body- Rayleigh-Ritz method of functional approximation - variational approaches - weighted residual methods.

UNIT-II

Finite Element Formulation of Truss Elements:

Stiffness matrix- properties of stiffness matrix – Selection of approximate displacement functions-solution of a plane truss- transformation matrix and stiffness matrix for a 3-D truss- Inclined and skewed supports- Galerkin's method for 1-D truss – Computation of stress in a truss element.

UNIT-III

Finite Element Formulation of Beam Elements:

Beam stiffness- assemblage of beam stiffness matrix- Examples of beam analysis for concentrated and distributed loading- Galerkin's method - 2-D Arbitrarily oriented beam element – inclined and skewed supports – rigid plane frame examples.

UNIT-IV

Finite Element Formulation:

plane stress, plane strain and axisymmetric problems- Derivation of CST and LST stiffness matrix and equations-treatment of body and surface forces-Finite Element solution for plane stress and axisymmetric problems- comparison of CST and LST elements –convergence of solution- interpretation of stresses.

UNIT-V

Iso-Parametric Formulation:

An iso-parametric bar element- plane bilinear isoparametric element – quadratic plane element - shape functions, evaluation of stiffness matrix, consistent nodal load vector - Gauss quadrature- appropriate order of quadrature – element and mesh instabilities – spurious zero energy modes, stress computation- patch test.

Text Books:

- 1 Finite Element Method, S.S.Bhavakatti, New age international publishers.
ISBN-13: 978-8122438833
- 2 The Finite Element Methods in Engineering, SS Rao, Pergamon.
ISBN-13: 978-0080952048
- 3 Fundamentals of Finite Element Analysis, David Hutton, Tata McGraw Hill Publishing Company Limited. , **ISBN-13:** 978-0071127959

Reference Books:

- 1 An introduction to Finite Element Method, JN Reddy, McGraw Hill.
ISBN-13: 978-0072466859
- 2 Introduction to Finite Elements in Engineering, Tirupati R.Chandrupatla, Ashok D.Belgunda, PHI publications. **ISBN-13:** 978-8120327726
- 3 Finite Element Method with applications in Engineering, YM Desai, Eldho & Shah, Pearson publishers. . **ISBN-13:** 978-8131711208
- 4 Rao.S.S, Finite Element Method in Engineering, Butterworth–Heinmann
ISBN-13: 978-1856176613

Web Links:

- 1 <http://nptel.ac.in/courses/112104116/>
- 2 www.onlinecourses.nptel.ac.in/noc21_me71/preview

COMPUTER AIDED DESIGN LABORATORY

Course Code: 242CE007

L T P C
0 0 2 2

Course Outcomes:

At the end of the Course, Student will be able to:

- CO 1: Develop Computer Programs for Analysis and Design of various Structural Elements.
- CO 2: Use different Structural Engineering software's to solve various civil Engineering programs.
- CO 3: Summarize the performance of structures for static and dynamic forces.
- CO 4: Skill in Analyzing Plane and Space Frames for Structural Integrity
- CO 5: Ability to Determine Mode Shapes and Natural Frequencies of Tall Buildings Using Lumped Mass Approximation

Mapping of course outcomes with program outcomes:

CO/PO	PO1	PO2	PO3	PO4	PO5	PO6
CO1	3	3	2	-	-	2
CO2	3	3	2	-	-	2
CO3	3	3	2	-	-	2
CO4	3	3	2	-	-	2
CO5	3	3	2	-	-	2

Mapping of course outcomes with program Specific Outcomes:

CO/PSO	PSO1	PSO2
CO1	1	-
CO2	1	-
CO3	1	-
CO4	1	-
CO5	1	-

Practice:

Analysis and Design using STADD, STADD FOUNDATION, ETABS, ANSYS

1. Programming for beams subject to different loading
2. Analysis and Design of reinforced concrete multi-storied building
3. Analysis of plane and space truss
4. Analysis of plane and space frame
5. Determination of mode shapes and frequencies of tall buildings using lumped mass (stick model) approximation

Text Books:

1. Design of Reinforced Concrete Structures by N. Subramanian
ISBN: 978-0198086949
2. Structural Analysis by R.C. Hibbeler
ISBN: 978-0134610676

Reference Books:

1. Computer aided design laboratory (Civil Engineering) by Shesha Prakash and Suresh.S
ISBN-13: 978-8189866750

Web Links:

1. http://web.iitd.ac.in/~hegde/cad/lecture/L01_Introduction.pdf 2
2. <https://nptel.ac.in/courses/112/102/112102101/>
3. <http://www.brcmcet.edu.in/downloads/files/n51e62e7a42189.pdf>

STRUCTURAL ENGINEERING LABORATORY

Course Code: 242CE008

L T P C
0 0 2 2

Course Outcomes:

At the end of the Course, Student will be able to:

- CO 1: Develop Computer Programs for Analysis and Design of various Structural Elements
- CO 2: Use different Structural Engineering software's to solve various civil Engineering programs.
- CO 3: he principles for the design of experiments.
- CO 4: Skill in Analyzing Bridge Piers and Abutments Using STAAD FOUNDATION and ETABS
- CO 5: Competence in Dynamic Analysis of Multi-Story Structures Using ETABS and ANSYS

Mapping of course outcomes with program outcomes:

CO/PO	PO1	PO2	PO3	PO4	PO5	PO6
CO1	3	3	2	-	-	2
CO2	3	3	2	-	-	2
CO3	3	3	2	-	-	2
CO4	3	3	2	-	-	2
CO5	3	3	2	-	-	2

Mapping of course outcomes with program specific outcomes:

CO/PSO	PSO1	PSO2
CO1	1	-
CO2	1	-
CO3	1	-
CO4	1	-
CO5	1	-

Practice:

Analysis and Design using STAAD, STAAD FOUNDATION, ETABS, ANSYS

1. Wind analysis on tall structure
2. Analysis of pre stressed concrete bridge girder
3. Analysis of Cylindrical shell
4. Analysis of Bridge Pier and Abutment
5. Dynamic Analysis of Multistory structure

Text Books:

1. Design of Reinforced Concrete Structures by N. Subramanian **ISBN:** 978-0198086949
2. Structural Analysis by R.C. Hibbeler **ISBN:** 978-0134610676

Reference Books:

1. Computer aided design laboratory (Civil Engineering) by Shesha Prakash and Suresh.S
ISBN-13: 978-8189866750

Web Links:

1. http://www.aust.edu/civil/lab_manual/ce_312.pdf
2. https://www.iare.ac.in/sites/default/files/lab1/IARE_ASAD_LAB_MANUAL
3. <https://lecturenotes.in/m/16886-lab-manuals-of-staad-pro-by-nick-avis?Reading=true>

MATRIX ANALYSIS OF STRUCTURES

Course Code: 242CE009

L T P C
3 0 0 3

Course Outcomes:

At the end of the Course, Student will be able to:

- CO 1: Apply the concepts of matrix methods to model trusses, beams, and frames.
- CO 2: Analyse structures using matrix methods by analytical methods and software tools with different degrees of freedom.
- CO 3: Evaluate and compare the behavior of structural elements under different boundary conditions.
- CO 4: Analyse continuous beams with or without settlement using the flexibility approach.
- CO 5: Apply the stiffness method for grid elements, including tapered and curved beams.

Mapping of Course Outcomes with Program Outcomes:

CO/PO	PO1	PO2	PO3	PO4	PO5	PO6
CO1	2	-	2	-	-	-
CO2	3	1	2	2	-	-
CO3	3	1	2	-	-	-
CO4	2	1	2	-	-	-
CO5	2	1	2	-	-	-

Mapping of Course Outcomes with Program Specific Outcomes:

CO/PSO	PSO1	PSO2
CO1	2	-
CO2	3	1
CO3	3	1
CO4	3	1
CO5	3	1

UNIT-I

Introduction of matrix methods of analysis:

Static and kinematic indeterminacy – Degree of freedom – Structure idealization-stiffness and flexibility methods – Suitability: Element stiffness matrix for truss element, beam element and

Torsional element- Element force - displacement equations

UNIT-II

Stiffness method:

Element and global stiffness equation – coordinate transformation and global assembly – structure stiffness matrix equation – analysis of simple pin jointed trusses –continuous beams– rigid jointed plane frames.

UNIT-III

Stiffness method for Grid elements:

Development of stiffness matrix – coordinate transformation. Examples of grid problems – tapered and curved beams.

UNIT-IV

Additional topics in stiffness methods:

Discussion of band width – semi band width – static condensation – sub structuring – Loads between joints-Support displacements- inertial and thermal stresses-Beams on elastic foundation by stiffness method.

UNIT-V

Analysis of plane truss:

Continuous beams with and without settlement - plane frame including side sway single storey, single – bay and gable frame by flexibility method using system approach.

Text Books:

1. Matrix methods of Structural Analysis by G.S.Pandit and S.P.Gupta, Tata McGraw Hill Co. **ISBN-13:** 978-0074622409
2. Matrix Analysis of framed Structures by W Weaver and Gere, Van Nostrand Reinhold. **ISBN-13:** 978-0442203802

Reference Books:

1. Matrix analysis of structures- Robert E Sennet- Prentice Hall-Englewood cliffs-New Jersey. **ISBN-13:** 978-0134875506
2. S.Rajasekaran, G. Sankarasubramanian “Computational Structural Mechanics”, Prentice-Hall of India Pvt Ltd, 7 th Edition, 2015, New Delhi. **ISBN-13:** 978-8120349502
3. Damodar Maity, “Computer Analysis of Framed Structures” I K International Publishing House Pvt. Ltd., 2007, ISBN-13: 978-8189866198. **ISBN-13:** 978-8189866198

Web Links:

1. <https://nptel.ac.in/courses/105105180/>
2. <https://lecturenotes.in/materials/16824->
3. <https://theconstructor.org/structural-engg/analysis>

STRUCTURAL DYNAMICS

Course Code: 242CE010

L	T	P	C
3	0	0	3

Course Outcomes:

At the end of the Course, Student will be able to:

- CO 1 : Explain the response of structural systems to dynamic loads.
- CO 2 : Demonstrate the behaviour and response of linear non SDOF and MDOF.
- CO 3 : Utilize the behaviour and response of MDOF structures with various dynamic loadings.
- CO 4 : Apply the ability to find out suitable solution for continuous system.
- CO 5 : Design of multi-story building using earthquake load.

Mapping of Course Outcomes with Program Outcomes:

CO/PO	PO1	PO2	PO3	PO4	PO5	PO6
CO1	2	1	2	-	-	-
CO2	2	1	2	-	-	-
CO3	2	1	2	-	-	-
CO4	2	1	2	-	-	-
CO5	3	2	2	-	1	2

Mapping of Course Outcomes with Program Specific Outcomes:

CO/PSO	PSO1	PSO2
CO1	1	-
CO2	1	-
CO3	2	-
CO4	2	-
CO5	1	-

UNIT-I

Theory of vibrations:

Introduction - Elements of vibratory system - Degrees of Freedom- Continuous System - Lumped mass idealization - Oscillatory motion - Simple Harmonic motion - Victorian representation of S.H.M. - Free vibrations of single degree of freedom system - undamped and damped vibrations - critical damping - Logarithmic decrement - Forced vibration of SDOF systems - Harmonic excitation - Vibration Isolation -Dynamic magnification factor – Phase angle.

UNIT-II

Introduction to structural dynamics:

Fundamental objectives of dynamic analysis - Types of prescribed loading - Methods of discretization - Formulation of equations of motion by different methods – Direct equilibration using Newton’s law of motion / D’Alembert’s Principle, Principle of virtual work and Hamilton principle.

Single degree of freedom systems:

Formulation and solution of the equation of motion - Free vibration response - Response to Harmonic, Periodic, Impulsive and general dynamic loadings - Duhamel integral.

UNIT-III

Multi degree of freedom systems:

Selection of the degrees of Freedom - Evaluation of structural property matrices - Formulation of the MDOF equations of motion -Undamped free vibrations - Solutions of Eigen value problem for natural frequencies and mode shapes - Analysis of Dynamic response – Normal co-ordinates - Uncoupled equations of motion - Orthogonal properties of normal modes - Mode superposition procedure.

UNIT-IV

Practical vibration analysis:

Introduction - Stodola method - Fundamental mode analysis - Analysis of second and higher modes - Holzer method - Basic procedure.

Continuous Systems: Introduction - Flexural vibrations of beams - Elementary case – Derivation of governing differential equation of motion - Analysis of undamped free vibrations of beams in flexure - Natural frequencies and mode-shapes of simple beams with different end conditions - Principles of application to continuous beams.

UNIT-V

Introduction to earthquake analysis:

Deterministic Earthquake Response: Systems on Rigid Foundations -Types of Earthquake Excitations – Lumped SDOF Elastic Systems, Translational Excitations - Generalized coordinate -SDOF Elastic Systems, Translational Excitations, Linear Static Method – Analysis for obtaining response of multi storied RC Building.

Text Books:

1. Structural Dynamics Anil K Chopra, 4edition, Prentice Hall Publishers.
ISBN-13: 978-0134872291
2. Structural Dynamics Theory & Computation – Mario Paz, CBS Publishes and Distributors. **ISBN-13:** 978-8120326022
3. Elementary Structural Dynamics- V.K. Manika Selvam, Dhanpat Rai Publishers.
ISBN-13: 978-8177001756

Reference Books:

1. Dynamics of structures by Clough and Penzien, 3rd edition, Computer of Structures - Int. **ISBN-13:** 978-0134872291
2. Theory of vibration - William Thomson, Springer Science. **ISBN-13:** 978-0387950846
3. Mechanical vibrations - S.S. Rao, 5th edition, Pearson Publications.
ISBN-13: 978-0132854285
4. Structural dynamics of Earthquake engineering - Theory and applications using Mathematics and Mat lab - S. Rajasekharan. **ISBN-13:** 978-0128046718

Web Links:

1. <http://nptel.ac.in/courses/105108070/>
2. <https://www.youtube.com/watch?v=2d8YsXwm7M>
3. <http://www.sciencedirect.com/science/book/9780080570693>

STABILITY OF STRUCTURES

Course Code: 242CE011

L	T	P	C
3	0	0	3

Course Outcomes:

At the end of the Course, Student will be able to:

- CO 1: Analyse different types of structural instabilities.
- CO 2: Execute and work out the elastic buckling using various methodologies.
- CO 3: Examine the behaviour of beam columns using classical methods.
- CO 4: Workout the torsional buckling of open cross sections.
- CO 5: Obtain the simply supported beams due to lateral and flexural buckling.

Mapping of course outcomes with program outcomes:

CO/PO	PO1	PO2	PO3	PO4	PO5	PO6
CO1	2	2	2	2	2	-
CO2	2	2	2	2	2	-
CO3	3	2	3	2	2	-
CO4	1	1	2	1	2	-
CO5	1	1	2	1	2	-

Mapping of course outcomes with program Specific Outcomes:

	CO/PSO	PSO1	PSO2	
	CO1	2	-	
	CO2	3	1	
	CO3	2	-	
	CO4	2	-	
	CO5	2	-	

UNIT-I

Beam – Column:

Differential equation for beam columns – Beams column with concentrated loads– continuous lateral load – Couples – Beam column with built in ends – Continuous beams with axial load – Application of Trigonometric series – Determination of allowable stresses.

UNIT-II

Elastic buckling of Bars:

Elastic buckling of straight columns – Effect of shear stress on buckling– Eccentrically and laterally loaded columns –Sway & Non Sway mode - Energy methods –Buckling of a bar on elastic foundation – Buckling of bar with intermediate compressive forces and distributed axial loads – Buckling of bars with change in cross section – Effect of shear force on critical load – Built up columns – Effect of Initial curvature on bars – Buckling of frames – Sway & Non Sway mode.

UNIT-III

In-elastic Buckling:

Buckling of straight bars – Double modulus theory Tangent modulus theory. Experiments and design formulae: Experiments on columns – Critical stress diagram – Empirical formulae of design – various end conditions – Design of columns based on buckling. Mathematical Treatment of stability problems: Buckling problem orthogonality relation – Ritz method –Stiffness method and formulation of Geometric stiffness matrix- Applications to simple frames

UNIT-IV

Torsional Buckling:

Pure torsion of thin walled bars of open cross section – Non uniform torsion of thin walled bars of open cross section - Torsional buckling – Buckling of Torsion and Flexure.

UNIT-V

Lateral Buckling:

Lateral Buckling of simply supported Beams - Beams of rectangular cross section subjected for pure bending, Buckling of I Section subjected to pure bending.

Text Books:

1. Theory of Stability of Structures by Alexander Chajes. Prentice Hall.
ISBN-13: 978-0139144938
2. Theory of Elastic Stability by S. P. Timshenko & J.M. Gere-Mc Graw Hill Publications. **ISBN-13:** 978-0070702426

Reference Books:

1. Fundamentals of Structural Stability by George J Smith & Dewey H. Hodges, Elsevier Publications. **ISBN-13:** 978-0750678759
2. Elastic Stability of Structural Elements, N.G.R. Iyengar Macmillan Publications..

Web Links:

1. https://theconstructor.org/structural-engg/basic-concepts-stability-structure/_1887/
2. https://www.engbookspdf.com/uploads/pdf_books/Principles of Structural Stability TheoryCivilengineeringandEngineeringMechanicsSeriescompressed-1.pdf

EXPERIMENTAL TECHNIQUES AND INSTRUMENTATIONS

Course Code: 242CE012

L T P C
3 0 0 3

Course Outcomes:

At the end of the Course, Student will be able to:

- CO 1: Understand the working principles and uses of different types of strain Gauges.
- CO 2: Understand the different types of Non destructing test methods used in structures
- CO 3: Design the suitable model after applying the principle of model analysis to the prototype
- CO 4: Understand the distress measurements of various structures
- CO 5: Understand the working principle of various measuring display Instrumentation.

Mapping of course outcomes with program outcomes:

CO/PO	PO1	PO2	PO3	PO4	PO5	PO6
CO1	2	1	1	-	2	-
CO2	2	1	1	-	2	-
CO3	2	1	1	-	2	-
CO4	2	1	1	-	2	-
CO5	2	1	1	-	2	-

Mapping of course outcomes with program Specific outcomes:

CO/PSO	PSO1	PSO2
CO1	-	1
CO2	-	2
CO3	-	2
CO4	-	2
CO5	-	2

UNIT-I

Strain Gauges:

Mechanical strain gauge – optical strain gauge – electrical resistance strain gauge - description and operation – inductance and capacitance strain gauges-strain rosettes – measurement of static and dynamic strain – effect of transverse strains –use of strain recorders and load cells –calibration of testing machines

UNIT-II

NDT Methods:

Load testing towers - brittle coating method - Moire fringe method- Ultra sonic pulse velocity technique - Rebound hammer method - X-ray method - Gamma ray method - corrosion measurements - linear polarization resistance - rapid chloride ion penetration test-open circuit potential measurements –Electrical impedance spectroscopy

UNIT-III

Model Analysis:

Structural similitude – use of models –structural and dimensional analysis – Buckingham pi theorem – Muller Breslau’s principle for direct and indirect analysis – use of Begg Eny’s deformeter– moment indicators – design of models for direct and indirect analysis.

UNIT-IV

Distress Measurements:

Diagnosis of distress in structures - crack observation and measurement Cracking due to corrosion of reinforcement in concrete construction and use - Damage assessment - controlled blasting for demolition.

UNIT-V

Vibration Measurements:

LVDT(linear variable differential transducer) –transducers for velocity and acceleration measurement vibration meter – seismographs – vibration analyser –display and recording signals –cathode ray oscillograph – XY plotter - chart plotter – digital acquisition systems.

Text Books:

1. Experimental Methods for Engineers” by J.P. Holman **ISBN-13:** 978-0073529303
2. Experimental Techniques & Instrumentation by M. Sreenivasa Reddy, S. Govindarajan and S. Pachaiappan, Charulatha Publications, 2022
ISBN-13 978-93-5577-370-8
3. "Introduction to Instrumentation and Measurements" by Robert B. Northrop
ISBN-13: 978-1439825842
4. "Experimental Methods in Structural Engineering" by C. C. Chou and J. W. Chen **ISBN-13:** 978-1842658453

5. "Measurement Systems: Application and Design" by Ernest O. Doebelin and Dhanesh N. Manik **ISBN-13:** 978-0071332431

Reference Books:

1. Dally J. W. & Riley W.F , "Experimental Stress Analysis" , McGraw Hill Book Company, New York , USA. **ISBN-13:** 978-0070152047
2. Dove.R.C. & Aedams .P.H, "Experimental Stress Analysis and Motion measurements", Prentice Hall of india Ltd ,NewDelhi.
ISBN-13: 978-0133300958
3. Sadhu Singh , "Experimental Stress Analysis" , Khanna Publishers , New Delhi
ISBN-13: 978-8174091378
4. Sirohi.R., S Radhakrishna. H.C "Mechanical measurements", new Age International (p) Ltd. **ISBN-13:** 978-8122404117

Web Links:

1. <https://theconstructor.org/structural-engg/basic-concepts-stability-structure/ 1887/>
2. <https://www.engbookspdf.com/uploads/pdf books/Principles of Structural Stability TheoryCivilengineeringandEngineeringMechanicsSeriescompressed-1.pdf>

ANALYTICAL & NUMERICAL METHODS FOR STRUCTURAL ENGINEERING

Course Code: 242CE013

L T P C
3 0 0 3

Course Outcomes:

At the end of the Course, Student will be able to:

- CO 1 : Understand the fundamentals of the numerical study.
- CO 2 : Implement the principles and techniques of elliptic's.
- CO 3 : Obtain the principles and techniques of integral methods.
- CO 4 : Adopt the principles and techniques for simply supported beams, columns and rectangular plates.
- CO 5 : Calculate the slope and deflection of beams by using different methods.

Mapping of Course Outcomes with Program Outcomes:

CO/PO	PO1	PO2	PO3	PO4	PO5	PO6
CO1	2	-	1	-	2	-
CO2	2	1	1	-	2	-
CO3	2	-	1	-	2	-
CO4	2	1	1	-	2	-
CO5	2	1	2	-	2	-

Mapping of Course Outcomes with Program Specific Outcomes:

CO/PSO	PSO1	PSO2
CO1	1	-
CO2	2	-
CO3	2	-
CO4	3	-
CO5	3	-

UNIT-I

Transform methods:

Laplace transform methods for one-dimensional wave equation - Displacements in a long string - Longitudinal vibration of an elastic bar - Fourier transforms methods for one-dimensional heat conduction problems in infinite and semi- infinite rod.

UNIT-II

Elliptic equations:

Laplace equation - Properties of harmonic functions - Fourier transform methods for Laplace equation.

Calculus of variations:

Variation and its properties - Euler's equation - Functionals dependent on first and higher order derivatives - Functionals dependent on functions of several independent variables - Some applications - Direct methods - Ritz and Kantorovich methods.

UNIT-III

Integral equations:

Fredholm and Volterra integral equations - Relation between differential and integral equations - Green's function - Fredholm equation with separable kernel - Iterative method for solving equations of second kind.

UNIT-IV

Finite Difference and their Applications:

Introduction- Differentiation formulas by Interpolating parabolas – Backward and forward and central differences- Derivation of Differentiation formulas using Taylor series- Boundary conditions- Beam deflection – Solution of characteristic value problems - Richardson's extrapolation - Use of unevenly spaced pivotal points- Integration formulae by interpolating parabolas- Numerical solution to spatial differential equations –Application to Simply Supported Beams, Columns & rectangular Plates.

UNIT-V

Numerical Differentiation:

Difference methods based on undetermined coefficients- optimum choice of step length– Partial differentiation. Numerical Integration: Method based on interpolation-method based on undetermined coefficient – Gauss – Lagrange interpolation method- Radaua integration method- composite integration method – Double integration using Trapezoidal and Simpson's method – New Marks Method and Application to Beams – Calculations of Slopes & Deflections.

Text Books:

1. Introduction to Partial Differential Equations, Sankara Rao. K, PHI, New Delhi, 1995. **ISBN-13:** 978-8120306871
2. Elements of Partial Differential Equations, Sneddon. I.N, Mc Graw Hill, 1986. **ISBN-13:** 978-0070621796

Reference Books:

1. Differential Equations and Calculus of Variations Elsgolts. L, Mir Publishers, Moscow. **ISBN-13:** 978-5030003126
2. Fundamentals of Mathematical Statistics Gupta. S.C, & Kapoor. V.K, Sultan

Chand & Sons, Reprint. **ISBN-13:** 978-8180547027
3. Engineering Maths for Engg. And Sciences Venkataraman. M. K,
National Publishing Company, Chennai. **ISBN-13:** 978-8183893459

Web Links:

1. <https://nptel.ac.in/courses/105/106/105106054/>
2. <https://nptel.ac.in/courses/105/105/105105041/>

DESIGN OF FOUNDATIONS

Course Code: 242CE014

L T P C
3 0 0 3

Course Outcomes:

At the end of the Course, Student will be able to:

- CO 1: Estimate bearing capacity of shallow foundation
- CO 2: Design of raft footing for a given site condition
- CO 3: Determine safe load carrying capacity of pile for a given site condition
- CO 4: Evaluate stability of well foundation
- CO 5: Design of foundations in expansive soils

Mapping of course outcomes with program outcomes:

CO/PO	PO1	PO2	PO3	PO4	PO5	PO6
CO1	3	1	-	-	2	-
CO2	3	1	-	-	2	-
CO3	3	1	-	-	2	-
CO4	3	1	-	-	2	-
CO5	3	1	-	-	2	-

Mapping of course outcomes with program Specific Outcomes:

CO/PSO	PSO1	PSO2
CO1	1	-
CO2	2	-
CO3	1	-
CO4	2	-
CO5	1	-

UNIT I

Introduction to RC Foundations:

Principles of Design of Foundations, Types of shear failures in foundation soils, Types of foundations, Design Loads, Basic Concepts of safe and allowable bearing capacity. Shallow Foundations Bearing Capacity Analysis: Bearing capacity theories – Terzaghi, Meyerhof, Skempton, Hansen, Vesic and IS Methods, Bearing capacity evaluation from Standard Penetration test and Plate load test.

UNIT-II

Proportioning of footings:

Isolated column footings, Strip, combined Footings and Strap Footing. Raft Foundations: Bearing capacity of raft foundation, floating raft, Types of rafts, Beam on Elastic foundation and Conventional methods of Design, determination of modulus of subgrade reaction.

UNIT-III

Deep Foundations:

Pile Foundations: Types, load capacity- dynamic formulae, static formula; pile load tests- Vertical load test, lateral load test, Cyclic load test; settlement of piles and pile groups, negative skin friction on single pile and pile groups; laterally loaded piles - Broom's Analysis, IS Code method; Under reamed piles – Load capacity, design and construction.

UNIT-IV

Well Foundations:

Types, Bearing Capacity of well foundations, Construction of pneumatic caissons, Tilts and Shifts: precautions, Remedial measures; Lateral stability analysis by Terzaghi's Method, Design aspects of Components of well foundation.

Settlement Analysis:

Uniform and Differential Settlements, Elastic and Consolidation Settlements, Settlement analysis in cohesionless soils by Schemartmann and Hartman method, Penetration tests; Permissible settlements as per IS 1904-1978, causes of settlement, settlement Control.

UNIT-V

Foundations in Expansive Solis:

Introduction, Identification of expansive soils, Swell potential and swelling pressure, Active depth, Foundation Problems, Foundation practices in expansive soils, Soil Replacement and 'CNS' concepts. Foundations of Transmission Line Towers - Introduction, Necessary information, Forces on tower foundations, General design criteria, Choice and type of foundation, Design procedure.

Text Books:

1. Design of Reinforced Concrete Foundations by P. C Varghese, PHI Learning Private Limited., New Delhi. **ISBN-13:** 978-8120327876
2. Pile Foundations in Engineering Practice by S. Prakashand H.D. Sharma, John Wiley & Sons. **ISBN-13:** 978-0471616535

Reference Books:

1. Reinforced Concrete Design by Unnikrishna Pillai and Devdas Menon, Tata McGraw **ISBN-13:** 978-0070141102
2. Analysis and Design of Substructures: Limit state Design by Swami Saran **ISBN-13:** 978-0198083528

Web Links:

1. <https://nptel.ac.in/courses/105/108/105108069/>
2. https://nptel.ac.in/content/storage2/nptel_data3/html/mhrd/ict/text/105105176/lec29._pdf
3. <https://nptel.ac.in/content/storage2/courses/105105104/pdf/m11129.pdf>
4. <https://nptel.ac.in/content/storage2/courses/105105104/pdf/m11128.pdf>

BRIDGE ENGINEERING

Course Code: 242CE015

L	T	P	C
3	0	0	3

Course Outcomes:

At the end of the Course, Student will be able to:

- CO 1: Explain the basic concepts of bridges
- CO 2: Apply various concepts of super structure and substructure in design of bridges.
- CO 3: Design Culvert, R.C.C T Beam Bridge according to the given specifications.
- CO 4: Design of Plate girder bridges
- CO 5: Design of Abutments, Piers and Pipe Culverts.

Mapping of course outcomes with program outcomes:

CO/PO	PO1	PO2	PO3	PO4	PO5	PO6
CO1	3	1	1	-	2	-
CO2	3	2	1	-	2	-
CO3	3	2	1	-	2	-
CO4	3	2	1	-	2	-
CO5	3	2	1	-	2	-

Mapping of course outcomes with program specific outcomes:

CO/PSO	PSO1	PSO2
CO1	1	-
CO2	2	-
CO3	2	-
CO4	2	-
CO5	2	-

UNIT-I

Concrete bridges:

Introduction-Types of Bridges-Economic span Length –Types of loading-Dead load-live load-Impact Effect-Centrifugal force-wind loads-Lateral loads - Longitudinal forces-Seismic loads- Frictional resistance of expansion bearings Secondary Stresses-Temperature Effect-Erection Forces and effects-Width of roadway and footway-General Design Requirements.

UNIT-II

Analysis of Bridges:

Design of longitudinal girders-Guyon-Messonnet method- Hendry Jaegar method-

Courbon's theory. (Ref: IRC-21), voided slabs, Super Structure: Slab bridge- Wheel load on slab- effective width method- slabs supported on two edges- cantilever slabs- dispersion length- Design of interior panel of slab- T-Beam bridges.

UNIT-III

Box culverts:

Single Cell Box Culvert – Design Loads, Design Moments, Shears and Thrusts. Design of Critical sections.

UNIT-IV

Plate girder bridges:

Elements of plate girder and their design-web flange-intermediate stiffeners-vertical stiffeners-bearing stiffener-design problem.

UNIT-V:

Substructure:

Analysis and Design of Abutment and Pier. Introduction to Design of Open Well, Pile and Caisson Foundations.

Text Books:

1. Design of Bridges by N. Krishna Raju CBS Publishers and Distributors.
ISBN-13: 978-8123904555
2. Concrete Bridge Design and Practice- V.K. Raina, Tata McGraw- Hill Publishing Company Limited. **ISBN-13:** 978-0074515817

Reference Books:

1. Design of Concrete Bridges- M.G. Aswini, V.N. Vazirani, M.M Ratwani, Khanna Publishers. **ISBN-13:** 978-8174091996
2. Essentials of Bridge Engineering-Jhonson Victor D, 7e, Oxford IBH Publications.
ISBN-13: 978-8120417171

Web Links:

1. <https://www.nptel.ac.in/courses/105105165/>
2. <http://www.engineeringenotes.com/civil-engineering/culvert/culvert-types-designprinciples-and-parameters-civil-engineering/39613>
3. [IRC 6- 2016 Standard Specifications and Code of Practice for Road bridges](#)
4. [IRC 112-2011 Code of Practice for Concrete Road Bridge](#)
5. https://onlinecourses.nptel.ac.in/noc22_ce63/

STRUCTURAL AUDITS

Course Code: 242CE016

L T P C
3 0 0 3

Course Outcomes:

At the end of the course, student will be able to:

- CO:1 Gain the knowledge of Bye laws, procedure of Structural audit and study the typical problems in structures
- CO:2 Aware of causes and types of deterioration in structures
- CO:3 Develop skills for use of various Non destructive tests required during auditing of structures
- CO:4 Strength evaluation of existing structures
- CO:5 Acquire knowledge of legal procedure to conduct structural audits
- CO:6 Prepare a Structural audit report

Mapping of Course Outcomes with Program Outcomes:

CO/PO	PO1	PO2	PO3	PO4	PO5	PO6
CO1	1	2	3	-	-	-
CO2	1	3	2	-	-	-
CO3	1	2	1	-	-	-
CO4	2	3	2	-	-	-
CO5	2	3	2	-	-	-
CO6	2	3	2	-	-	-

Mapping of course outcomes with program Specific Outcomes:

CO/PSO	PSO1	PSO2
CO1	1	-
CO2	2	-
CO3	1	-
CO4	2	-
CO5	1	-
CO6	2	-

UNIT- I:

Introduction to Structural Audit:

Introduction to Structural Audit, Objectives, Bye-laws, Importance, Various Stages involved, Visual inspection: scope, coverage, limitations, Factors to be keenly observed. Detailed Study of: RC frame and Masonry building: Structural and non structural system, Structural elements

concrete and its texture, sag and deflection in members, cracks: types and its fatality, Architectural features like balconies, cornices, etc their vulnerabilities, Probable damages in Structural and non structural walls, Plaster and paint Leakages and seepages, Plinth importance and how it affects suitability of building, Electric wiring: various damages and their fatality. Steel Structures: Corrosion, Connection defects, Connection strength, yielded member.

UNIT- II:

Causes and types of deterioration in Structures:

Causes of deterioration in RC frame and Masonry building: Permeability of concrete, capillary porosity, air voids, Micro cracks and macro cracks, corrosion of reinforcing bars, sulphate attack, alkali silica reaction,. Causes of deterioration in Steel Structures: Uniform deterioration, pitting, crevice, galvanic, laminar, Erosion, cavitations, fretting, Exfoliation, Stress, Causes of corrosion in various members, causes of defects in connection (bolted and welded), Cracks.

UNIT- III:

Non Destructive Testing:

Concrete Strength Assessment: Rebound hammer, Ultrasonic Pulse velocity, Penetration resistance, Pull out test, Chemical test: Carbonation test, Chloride test, Corrosion potential assessment: Cover meter survey, half cell potential, resistivity measurement, Fire damage assessment: Differential thermal analysis, X ray diffraction, Structural Integrity and soundness assessment: Radiography, Impact echo test, dynamic testing of structure, Interpretation and evaluation of test results.

UNIT- IV:

Strength Evaluation of Existing Structure :

Reserve strength, identification of critical sections, structural system and its validation, evaluation of damage in concrete and reinforcement, evaluation of building configuration.

Approach to conduct Structural Audits:

Guidelines of Statutory Bodies, Legal aspects, Responsibility of calling Structural Audit, Scope of Investigation, Involvement of Original Consultants & Representatives of Statutory Bodies, Frequency of Structural Audits.

UNIT- V:

Structural Audit Report

Draft Structural audit report for up-gradation of existing building, Audit for continuation of usage of old Buildings, Audit for Buildings damaged due to Flood, Earthquakes, Fire, Storms/cyclones, Landslides, Cloud Burst, Tsunamis and accidental events such as blasts/ wilful damages.

Text Books:

1. Indian Standard codes related with non destructive testing, Government Resolutions related to Structural Audits (BMC Act, etc.), Field manuals and reports by Expert Consultants.
2. Structural Audit: A New Paradigm by S.K. Sharma ISBN: 978-8174092295

Reference Books:

1. Structural Assessment: The Role of Large-Scale Testing by O. S. S. Williams **ISBN:** 978-0415588513
2. Reinforced Concrete: A Fundamental Approach by S. S. R. Prasad **ISBN:** 978-0074601468

Web Links:

1. <https://nptel.ac.in/courses/114/106/114106011/>
2. https://onlinecourses.nptel.ac.in/noc21_ce63

ANALYSIS OF OFFSHORE STRUCTURES

Course Code: 242CE017

L T P C
3 0 0 3

Course Outcomes:

At the end of the Course, Student will be able to:

- CO 1: Perform concept development of offshore structure.
- CO 2: Understand the concept of waves using static and kinematic theories.
- CO 3: Find the wave force on vertical cylinder.
- CO 4: Observe the wave force by various theories.
- CO 5: Perform static and dynamic analysis of fixed offshore structure.

Mapping of course outcomes with program outcomes:

CO/PO	PO1	PO2	PO3	PO4	PO5	PO6
CO1	1	2	2	1	1	-
CO2	2	1	2	-	-	-
CO3	3	1	2	-	-	-
CO4	3	2	2	-	-	-
CO5	3	2	2	1	1	-

Mapping of course outcomes with program Specific Outcomes:

CO/PSO	PSO1	PSO2
CO1	1	-
CO2	2	-
CO3	2	-
CO4	2	-
CO5	3	1

UNIT-I

Introduction to different types of offshore structures, Concept of fixed, compliant and floating structures, Law of floatation, fluid pressure and centre of pressure, estimation of centre of gravity, hydrostatic particulars, stability criteria of floating bodies, and motions of a floating body.

UNIT-II

Conservation mass and momentum, Euler equation, Bernoulli's Equation, Potential flow, Classification of waves, small amplitude or Linear Airy's theory, dispersion relationship, water particle kinematics, wave energy.

UNIT-III

Wave force estimation- Wave force on small bodies-Morison equation, Estimation of wave force on a vertical cylinder, Force due to current, Effect of marine growth on vertical cylinders.

UNIT-IV

Wave force on large bodies-Froude-Krylov theory, Diffraction theory.

UNIT-V

Static and dynamic analysis of fixed offshore structures.

Text Books:

1. Graff, W. J., Introduction to Offshore Structures, Gulf Publ. Co.
ISBN-13: 978-0872011207
2. Dawson, T. H., Offshore Structural Engineering, Prentice Hall.
ISBN-13: 978-0136316280

Reference Books:

1. Hand book of offshore Engineering, Vol I, Subrata Chakrabarti, Offshore Structure Analysis, Inc., Plain field, Illinois, USA. **ISBN-13:** 978-0080443812
2. API RP 2 A., Planning, Designing and Constructing Fixed Offshore Platforms, API.
3. McClelland, B & Reifel, M. D., Planning & Design of fixed Offshore Platforms, Van Nostrand, 1986. **ISBN-13:** 978-0442218301

Web Links:

1. <https://nptel.ac.in/courses/114/106/114106011/>
2. <http://www.ejse.org/Archives/Fulltext/2007/Special/200705.pdf>
3. <https://www.irjet.net/archives/V5/i1/IRJET-V5I1155.pdf>
4. <https://www.slideshare.net/surya3303/offshore-structures-presentation>

EARTHQUAKE RESISTANT DESIGN OF BUILDINGS

Course Code: 242CE018

L T P C
3 0 0 3

Course Outcomes:

At the end of the Course, Student will be able to:

- CO 1: To learn the fundamentals of seismology and basic earthquake mechanisms, tectonics types of ground motion, and propagation of ground motion.
- CO 2: Design of structural and non-structural elements with seismic design concepts.
- CO 3: Examine the frames and shear wall detailing under earthquake
- CO 4: Summarize cyclic loading behaviour of structural elements with various concepts.
- CO 5: Understand the failures of earthquake and Retrofitting, restoration techniques for buildings.

Mapping of course outcomes with program outcomes:

CO/PO	PO1	PO2	PO3	PO4	PO5	PO6
CO1	2	2	2	-	-	-
CO2	3	2	2	-	-	-
CO3	2	2	1	-	-	-
CO4	2	2	1	1	-	-
CO5	2	3	2	1	-	-

Mapping of course outcomes with program Specific Outcomes:

CO/PSO	PSO1	PSO2
CO1	1	-
CO2	3	1
CO3	2	-
CO4	2	-
CO5	1	-

UNIT-I

Engineering seismology – rebound theory – plate tectonics – seismic waves - earthquake size and various scales – local site effects – Indian seismicity – seismic zones of India – theory of vibrations – near ground and far ground rotation and their effects.

UNIT-II

Seismic design concepts – EQ load on simple building – load path – floor and roof diaphragms – seismic resistant building architecture – plan configuration – vertical configuration – pounding effects – mass and stiffness irregularities – torsion in structural system- Provision of seismic code (IS 1893 & 13920) – Building system – frames – shear wall – braced frames – layout design of Moment Resisting Frames (MRF) – ductility of MRF – Infill wall – Non- structural elements.

UNIT-III

Calculation of EQ load – 3D modeling of building systems and analysis (theory only)
Design and ductile detailing of Beams and columns of frames Concept of strong column weak beams, Design and ductile detailing of shear walls.

UNIT-IV

Cyclic loading behavior of RC, steel and pre- stressed concrete elements - modern concepts- Base isolation – Adaptive systems – case studies.

UNIT-V

Retrofitting and restoration of buildings subjected to damage due to earthquakes- effects of earthquakes – factors related to building damages due to earthquake- methods of seismic retrofitting- restoration of buildings.

Text Books:

1. Earthquake Resistant Design of Structures Pankaj Agarwal and Manish ShriKhande, Prentice – Hall of India, New Delhi.
2. Earthquake Resistant Design of Structures- S.K. Duggal, Oxford Publications
ISBN-13: 978-8120337978

Reference Books:

1. Seismic design of reinforced concrete and masonry buildings by Paulay and Priestley. **ISBN-13:** 978-0471549154
2. Earthquake Resistant Design and Risk Reduction- David Dowrick.
ISBN-13: 978-0470012376
3. IS 4326 -1998: Earthquake Resistant Design and Construction of Buildings.
4. IS 1893 (Part 1 to 5)- 2016: General Provisions and Building.
5. IS 4928–1993: Code of practice for Earthquake Resistant Design and Construction of Buildings.
6. IS 13920-2016: Code of Practice for Ductile Detailing of Reinforced Concrete Structures subjected to Seismic Forces.

Web Links:

1. <http://nptel.ac.in/courses/105105104/pdf/m16139.pdf>. 2
2. <https://www.slideshare.net/mvm2594/earthquake-resistant-designs-12158375>.
3. http://peer.berkeley.edu/course_modules/eqrd/227info03/Lect1Intro03.pdf

PRECAST AND PREFABRICATED STRUCTURES

Course Code: 242CE019

L	T	P	C
3	0	0	3

Course Outcomes:

At the end of the Course, Student will be able to:

- CO 1: Explain the need for fabrication and types of prefabrication.
- CO 2: Apply the design of prefabricated load carrying members.
- CO 3: Develop the effective sealing of joints for water proofing.
- CO 4: Determine the functions and design principles of production equipment and hoisting equipment.
- CO 5: Develop the designing and detailing of precast unit for factory structures.

Mapping of course outcomes with program outcomes:

CO/PO	PO1	PO2	PO3	PO4	PO5	PO6
CO1	3	-	2	-	-	-
CO2	3	-	2	-	-	-
CO3	3	-	2	-	-	-
CO4	3	-	2	-	-	-
CO5	3	-	2	-	-	-

Mapping of course outcomes with program Specific Outcomes:

CO/PSO	PSO1	PSO2
CO1	-	-
CO2	1	-
CO3	2	1
CO4	2	2
CO5	3	1

UNIT-I

Need for prefabrication:

General Principles of Prefabrication - Comparison with monolithic construction, types of prefabrication, site and plant prefabrication, economy of prefabrication, modular coordination, standardization – Materials – Modular coordination – Systems – Production – Transportation – Erection.

UNIT-II

Prefabricated Load Carrying Members:

Planning for components of prefabricated structures, disuniting of structures, design of simple rectangular beams and I-beams, handling and erection stresses, elimination of erection stresses, beams, columns, symmetric frames. Behaviour of structural components – Large panel constructions – Construction of roof and floor slabs – Wall panels – Columns – Shear walls.

UNIT-III

Joints:

Joints for different structural connections, effective sealing of joints for water proofing, provisions for non-structural fastenings, expansion joints in precast construction.

UNIT-IV

Production Technology:

Choice of production setup, manufacturing methods, stationary and mobile production, planning of production setup, storage of precast elements, dimensional tolerances, acceleration of concrete hardening. Hoisting

Technology - Equipment for hoisting and erection, techniques for erection of different types of members like beams, slabs, wall panels and columns, vacuum lifting pads.

UNIT-V

Applications:

Designing and detailing of precast unit for factory structures, purlins, principal rafters, roof trusses, lattice girders, gable frames, single span single storied simple frames, single storied buildings, slabs, beams and columns. Progressive

collapse – Code provisions – Equivalent design loads for considering abnormal effects such as earthquakes, cyclones, etc., - Importance of avoidance of progressive collapse.

Text Books:

1. Precast Concrete Structures- Kim S Elliott, CRC Press. **ISBN-13:** 978-0419231800
2. CBRI, Building materials and components, India.
3. Gerostiza C.Z., Hendrikson C. and Rehat D.R., Knowledge based process planning for construction and manufacturing, Academic Press Inc. **ISBN-13:** 978-0122818807
4. Koncz T., Manual of precast concrete construction, Vols. I, II and III, Bauverlag, GMBH. **ISBN-13:** 978-3762504466

Reference Books:

1. Structural design manual, Precast concrete connection details, Society for the studies in the use of precast concrete, Netherland Betor Verlag.
2. Mokka L, Prefabricated Concrete for Industrial and Public Structures, Publishing House of the Hungarian Academy of Sciences, Budapest.

Web Links:

1. https://en.wikipedia.org/wiki/Precast_concrete
2. <https://www.iiti.ac.in/event/precast-and-prefabricated-buildings>
3. [http://molotilo.com/types-of-houses/prefab/design-what-is-the-basic-difference-between-precast-and-prefabricated-structures-quora.](http://molotilo.com/types-of-houses/prefab/design-what-is-the-basic-difference-between-precast-and-prefabricated-structures-quora)

EARTH RETAINING STRUCTURES

Course Code: 242CE020

L	T	P	C
3	0	0	3

Course Outcomes:

At the end of the Course, Student will be able to:

- CO 1: Explain the lateral earth pressure associated with different earth systems.
- CO 2: Apply the design of retaining structures by using appropriate design methods and earth pressure diagrams.
- CO 3: Develop the location of sheet pile walls and design of anchorage system.
- CO 4: Determine the functions and design principles of reinforced earth retaining structures.
- CO 5: Develop the stability aspects of braced cuts and coffer dams.

Mapping of course outcomes with program outcomes:

CO/PO	PO1	PO2	PO3	PO4	PO5	PO6
CO1	3	1	2	-	1	-
CO2	3	1	2	-	1	-
CO3	3	1	2	-	1	-
CO4	3	1	2	-	1	-
CO5	2	1	2	-	1	-

Mapping of course outcomes with program Specific Outcomes:

CO/PSO	PSO1	PSO2
CO1	1	1
CO2	1	1
CO3	1	1
CO4	1	1
CO5	1	1

UNIT-I

Earth Pressures:

Different types and their coefficients- Classical Theories of Earth pressure – Rankine’s and coulombs theories for Active and Passive earth pressure- Computation of Lateral Earth Pressure in Homogeneous and Layered soils- Graphical solutions for Coulomb’s Theory in active and passive conditions.

UNIT-II**Retaining Walls:**

Different types- Types of failures of Retaining walls-Stability requirements-Drainage behind Retaining walls-Provision of joints-Relief Shells.

UNIT-III**Sheet Pile Structures:**

Types of Sheet piles- Cantilever sheet piles in sands and clays - Anchored sheet piles –Freeearth and Fixed earth support methods-Rowe's moment reduction method- Location of anchors and Design of Anchorage system.

UNIT-IV**Soil reinforcement:**

Reinforced earth -Different components -their functions -Design principles of reinforced earth retaining walls.

UNIT-V**Braced cuts and Cofferdams:**

Lateral Pressure in Braced cuts- Design of various components of a Braced cut- Stability of braced cuts -Bottom Heave in cuts-types of cofferdam, suitability, merits and demerits-Design of single-wall coffer dams and their stability aspects -TVA method and Cummins method.

Text Books:

1. Principles of Foundation Engineering 7edition by Braja Das, Cengage Learning **ISBN-13:** 978-0495668107
2. Foundation analysis and design by Bowles, J.E. –McGraw Hil
ISBN-13: 978-0071188441

Reference Books:

1. Soil mechanics in engineering practice-Terzaghi, K and Ralph, B.Peck johnsons.
ISBN-13: 978-0471086581

Web Links:

1. https://en.wikipedia.org/wiki/Retaining_wall
2. <https://www.aboutcivil.org/earth-retaining-structures.html>
3. <https://reinforcedearth.com/products/retaining-walls/mechanically-stabilized-earth-mse-retaining-walls/>

DESIGN OF PRE-STRESSED CONCRETE STRUCTURES

Course Code: 242CE021

L	T	P	C
3	0	0	3

Course Outcomes:

At the end of the Course, Student will be able to:

- CO 1: Explain the principle, types and systems of prestressing and analyze the losses.
- CO 2: Determine the deflections as per code references in pre-stressed concrete members.
- CO 3: Analyze the Composite construction of Pre-stressed members.
- CO 4: Design the pre-stressed concrete members of slabs, pipes and poles.
- CO 5: Analyze the continuous beams and end blocks by different theorems

Mapping of Course Outcomes with Program Outcomes:

CO/PO	PO 1	PO 2	PO 3	PO 4	PO 5	PO 6
CO1	3	2	3	2	2	-
CO2	2	2	2	-	2	-
CO3	3	2	3	2	2	-
CO4	3	2	3	2	2	-
CO5	3	2	2	2	2	-

Mapping of Course Outcomes with Program Specific Outcomes:

CO / PSO	PSO 1	PSO 2
CO1	2	-
CO2	2	-
CO3	3	1
CO4	3	1
CO5	3	1

UNIT-I

Introduction:

Prestressing Systems – Pretensioning Systems – Postensioning Systems – High Strength Steel and Concrete - Analysis of Prestress - Resultant Stresses at a Section – Pressure Line or Thrust Line – Concept of Load Balancing - Losses of Prestress – Loss Due to Elastic Deformation of Concrete – Shrinkage of Concrete – Creep – Relaxation of Stress in Steel – Friction – Anchorage Slip.

UNIT-II

Deflections of Prestressed Concrete Members:

Importance of Control of Deflections Factors Influencing Deflection – Short-term Deflections of Uncracked Members Prediction of Long-time Deflections – Deflections of Cracked Members – Requirements of IS 1343-2012.

UNIT –III

Composite Constructions:

Introduction, Advantages, Types of Composite Construction, Analysis of Composite beams- Differential shrinkage- Ultimate Flexural and shear strength of composite sections- Deflection of Composite Beams. Design of Composite sections.

UNIT-IV

Prestressed Concrete Slabs:

Types of Prestressed Concrete Floor Slabs- Design of Prestressed Concrete One Way and Two-Way Slabs.

Prestressed Concrete Pipes and Poles:

Circular prestressing- Types of Prestressed Concrete Pipes- Design of Prestressed Concrete Pipes - Prestressed Concrete Poles.

UNIT-V

Continuous Beams:

Advantage of Continuous Members – Effect of Prestressing Indeterminate Structures – Methods of Achieving Continuity – Methods of Analysis of Secondary Moments – Concordant Cable Profile – Guyon’s Theorem. Redistribution of moments in a continuous beam.

Anchorage Zone Stresses in Beams:

Introduction, Stress distribution in End Block - Anchorage zone stresses –Magnel’s method- Guyon’s Method - Anchorage zone Reinforcement.

Text Books:

1. Prestressed Concrete, 6e by N. Krishna Raju, Mc Graw Hill Publishers.
ISBN-13: 978-0070667807
2. Prestressed Concrete by K. U.Muthu, PHI Learning Pvt Limited.
ISBN-13: 978-8120342318

Reference Books:

1. Prestressed Concrete Analysis and Design, Antone E. Naaman 2e, Techno Press 3000. **ISBN-13:** 978-1932159184
2. Design of Prestressed Concrete- T. Y. Lin, Ned H. Burns 3e, Wiley Publications.
ISBN-13: 978-0471393838
3. Design of prestressed Concrete by E.G. Nawy. **ISBN-13:** 978-0136111338
4. Prestressed Concrete by N. Rajagopalan, Narosa Publishing.
ISBN-13: 978-8184872431
5. IS1343 2012 Prestressed concrete Code of Practice.

Web Links:

1. [http://icivil-hu.com/Civil-team/5th/prestressed/Dr.%20 Hazim%20 Slides/ Lecture %202.1% 20-%20Methods%20of%20Prestressing.pdf](http://icivil-hu.com/Civil-team/5th/prestressed/Dr.%20Hazim%20Slides/Lecture%202.1%20-%20Methods%20of%20Prestressing.pdf)
2. <http://www.velhightech.com/Documents/CE6702-PSC-notes-wecompress.com.pdf>
3. <https://web.itu.edu.tr/~haluk/COMPOSITE%201.pdf>

STRUCTURAL HEALTH MONITORING

Course Code: 242CE022

L T P C
3 0 0 3

Course Outcomes:

At the end of the Course, Student will be able to:

- CO 1: Diagnose the distress in the structure by understanding the causes and factors.
- CO 2: Assess the health of the structure using static field methods.
- CO 3: Assess the health of the structure using dynamic field tests.
- CO 4: Carryout repairs and rehabilitation measures of the structure.
- CO 5: Understand the electro mechanical impedance technique

Mapping of Course Outcomes with Program Outcomes:

CO/PO	PO 1	PO 2	PO 3	PO 4	PO 5	PO 6
CO1	2	3	1	1	1	-
CO2	2	3	2	1	-	-
CO3	2	3	2	1	-	-
CO4	2	3	1	1	-	-
CO5	2	3	2	1	-	-

Mapping of Course Outcomes with Program Specific Outcomes:

CO/ PSO	PSO 1	PSO 2
CO1	2	-
CO2	2	-
CO3	2	-
CO4	2	-
CO5	2	-

UNIT-I

Structural Health:

Factors affecting Health of Structures, Causes of distress, Regular Maintenance.

Structural Audit:

Assessment of Health of Structure, Collapse and Investigation, Investigation Management,

SHM Procedures.

UNIT-II

Structural Health Monitoring:

Concept, Various Measures, Structural Safety in Alteration Structural Audit: Assessment of Health of Structure, Collapse and Investigation, Investigation Management, SHM Procedures

UNIT –III

Dynamic Field Testing-I:

Types of Dynamic Field Test, Stress History Data, Dynamic Response Methods

UNIT-IV

Dynamic Field Testing-II:

Hardware for Remote Data Acquisition Systems, Remote Structural Health Monitoring.

UNIT-V

Introduction to Repairs and Rehabilitations of Structures:

Case Studies (Site Visits), Piezo–electric materials and other smart materials, electro–mechanical impedance (EMI) technique, adaptations of EMI technique.

Text Books:

1. Structural Health Monitoring, Daniel Balageas, Claus Peter Fritzen, Alfredo Güemes, John Wiley and Sons, 2006. **ISBN-13:** 978-0470032978
2. Health Monitoring of Structural Materials and Components Methods with Applications, Douglas E Adams, John Wiley and Sons, 2007. **ISBN-13:** 978-0470057452

Reference Books:

1. Structural Health Monitoring and Intelligent Infrastructure, Vol1, J. P. Ou, H. Li and Z. D.Duan, Taylor and Francis Group, London, UK. **ISBN-13:** 978-0415404872
2. Structural Health Monitoring with Wafer Active Sensors, Victor Giurgutiu, Academic Press Inc. **ISBN-13:** 978-0123736110

Web Links:

1. https://www.iitk.ac.in/ce/test/MoHUPA%20Presentation_Dr.K%20Roy%20_%20Dr.S.Mukhopadhy.pdf
2. <https://lecturenotes.in/subject/1397/structural-health-monitoring-and-rehabilitation>
3. <https://nptel.ac.in/courses/112/104/112104160/>

SOIL STRUCTURE INTERACTION

Course Code: 242CE023

L	T	P	C
3	0	0	3

Course Outcomes:

At the end of the Course, Student will be able to:

- CO 1: Relate the practical significance and importance of Soil-Structure interaction.
- CO 2: Model Soil-structure interaction problems using various concepts.
- CO 3: Compute various parameters associated with dynamic analysis of structure and foundation.
- CO 4: Understand the Material nonlinearity of soil.
- CO 5: Apply the theories of Dynamic Soil-Structure Interaction to various practical Engineering problems.

Mapping of course outcomes with program outcomes:

CO/PO	PO1	PO2	PO3	PO4	PO5	PO6
CO1	3	2	2	-	-	-
CO2	3	2	2	-	-	-
CO3	3	2	-	-	-	-
CO4	3	2	2	-	-	-
CO5	3	2	-	-	-	-

Mapping of course outcomes with program specific outcomes:

CO/PSO	PSO1	PSO2
CO1	-	-
CO2	-	-
CO3	-	-
CO4	-	-
CO5	-	-

UNIT – I

Introduction:

Objectives and practical significance and importance of Soil-Structure interaction (SSI); Fixed base structure, Structures on soft ground; Modelling of unbounded media.

UNIT – II

Fundamentals of Soil-Structure Interaction:

Rational methods of analysis of substructure; Equation of motion for flexible and rigid base; Kinematic interaction, Inertial interaction, and Effect of embedment.

UNIT – III

Modelling of Soil-structure interaction:

Discrete model Winkler, Pasternak, Filoneko-Borodich, Hetenyi, Kerr, Rhines; Continuum model: Vlazov, Reissner, Biots, Gorbunov and Posadov; Modeling of boundaries.

UNIT-IV

Concepts in dynamic analysis of structure and foundation:

Dynamic stiffness of Surface foundation, Embedded foundation, Shallow (strip) foundation and Deep (piles) foundations.

UNIT-V

Nonlinear Analysis

Material nonlinearity of soil, Geometrical nonlinearity; structure interaction.

Engineering Applications

Engineering Applications of Dynamic Soil-Structure Interaction.

Text Books:

- 1 Selva durai, A. P. S, “Elastic Analysis of Soil-Foundation Interaction”, Elsevier, 1979. **ISBN-13:** 978-0080230477
- 2 Bowles, J.E., “Foundation analysis and design”, McGraw Hill 1996. **ISBN-13:** 978-0071188447
- 3 Tomlinson, M. J., “Foundation Design and construction”, English language book society and pitman, London. **ISBN-13:** 978-0273785513
- 4 Chowdhury, I. and Dasgupta, S. P., “Dynamics of Structure and Foundation – A Unified Approach”, CRC Press, Balkema, 2009. **ISBN-13:** 978-0415475704

Reference Books:

- 1 Kurian, N. P., “Design of Foundation Systems – Principles and Practices”, Publishing House, New Delhi, Alpha Science International, U.K.,2005. **ISBN-13:** 978-1842651276
- 2 J.W. Bull, “Soil-Structure Interaction: Numerical Analysis and Modelling”, CRC Press, 1st edition,1994. **ISBN-13:** 978-0419181205
- 3 Desai C.S.& Christian J.T., “Numerical Methods in Geotechnical Engineering”, McGraw Hill. **ISBN-13:** 978-0070168600

Web Links:

- 1 <https://archive.nptel.ac.in/courses/105/105/105105200/>
- 2 https://onlinecourses.nptel.ac.in/noc20_ce22/preview

BASIC CONCRETE TECHNOLOGY

Course Code: 242CE030

L T P C
3 0 0 3

Course Outcomes:

At the end of the Course, Student will be able to:

- CO1: Understand the chemical composition, hydration, and physical properties of Portland cement.
- CO 2: Evaluate the effects of mineral and chemical admixtures on concrete performance.
- CO 3: Classify and assess aggregates based on mechanical properties, grading, and thermal behavior.
- CO 4: Analyze workability and setting characteristics of fresh concrete, including relevant testing methods.
- CO 5: Design and proportion concrete mixes using BIS and ACI methods, ensuring quality control.

Mapping of course outcomes with program outcomes:

CO/PO	PO 1	PO 2	PO 3	PO 4	PO 5	PO 6
CO1	2	3	1	-	-	-
CO2	2	1	3	-	-	-
CO3	2	1	3	-	-	-
CO4	2	1	3	-	-	-
CO5	2	2	3	-	-	-

Mapping of course outcomes with program Specific Outcomes:

CO/ PSO	PSO 1	PSO 2
CO1	-	-
CO2	-	-
CO3	-	-
CO4	-	-
CO5	-	-

UNIT – I :

Cement:

Portland cement – chemical composition – Hydration, Setting of cement – Structure of hydrate

cement – Test on physical properties – Different grades of cement. Admixtures: Types of admixtures – mineral and chemical admixtures.

UNIT - II

Aggregates:

Classification of aggregate – Particle shape & texture –, strength & other mechanical properties of aggregate – Specific gravity, Bulk density, porosity, adsorption & moisture content of aggregate – Bulking of sand – Deleterious substance in aggregate – Soundness of aggregate – Alkali aggregate reaction – Thermal properties – Sieve analysis – Fineness modulus – Grading curves – Grading of fine & coarse Aggregates – Gap graded aggregate – Maximum aggregate size.

UNIT – III

Fresh Concrete:

Workability – Factors affecting workability – Measurement of workability by different tests – Setting times of concrete – Effect of time and temperature on workability – Segregation & bleeding – Mixing and vibration of concrete – Steps in manufacture of concrete – Quality of mixing water.

UNIT - IV

Hardened Concrete:

Water / Cement ratio – Abram’s Law – Gelspae ratio – Nature of strength of concrete – Maturity concept – Strength in tension & compression – Factors affecting strength – Relation between compressive & tensile strength - Curing. Testing Of Hardened Concrete: Compression tests – Tension tests– Flexure tests – Splitting tests – Pull-out test, Non-destructive testing methods – codal provisions for NDT. Elasticity, Creep & Shrinkage – Modulus of elasticity – Dynamic modulus of elasticity – Poisson’s ratio – Creep of concrete – Factors influencing creep.

UNIT – V

Mix Design:

Factors in the choice of mix proportions – Durability of concrete – Quality Control of concrete – Statistical methods – Acceptance criteria – Proportioning of concrete mixes by IS codes mix design. Special Concretes: Introduction to light weight concrete – Cellular concrete

Text Books:

1. Properties of Concrete by A. M. Neville Pearson 5th edition Education ltd.
ISBN: 978-0273755807
2. Concrete Technology by M. S. Shetty. – S. Chand & Co.
ISBN: 978-8121900034

3. Concrete Technology by Job Thomas -Cengage learning India Pvt Ltd.
ISBN: 978-8131521099

References:

1. Concrete Technology by M.L. Gambhir. – Tata Mc. Graw Hill Publishers, New Delhi.
ISBN: 978-0070141100
2. Concrete: Microstructure, Properties and Materials – P. K. Mehta and J. M. Monteiro,
McGraw Hill Publishers
ISBN: 978-0071797870

Web Links:

1. www.Nptel.Ac.In/Courses/105102012/
2. www.archive.nptel.ac.in/noc/courses/noc15/SEM1/noc15-ce01
3. <https://archive.nptel.ac.in/courses/105/102/105102012/>

REPAIR AND REHABILITATION OF STRUCTURES

Course Code: 242CE031

L	T	P	C
3	0	0	3

Course Outcomes:

At the end of the Course, Student will be able to

- CO 1: Identify the causes of deterioration of concrete structures.
- CO 2: Illustrate the various materials for repair and rehabilitation techniques.
- CO 3: Construct the various strengthening and stabilization techniques.
- CO 4: Determine various repair techniques of damaged structures.
- CO 5: Evaluate the usage of different types of concretes and durability aspects.
- CO 6: Classify the usage of high performance concretes for repairing works.

Mapping of Course Outcomes with Program Outcomes:

CO/PO	PO 1	PO 2	PO 3	PO 4	PO 5	PO 6
CO1	3	2	2	2	2	-
CO2	3	2	2	2	2	-
CO3	3	2	2	2	2	-
CO4	3	2	2	2	2	-
CO5	2	2	1	2	1	-
CO6	1	1	2	1	1	-

Mapping of course outcomes with program Specific Outcomes:

CO / PSO	PSO 1	PSO 2
CO1	1	-
CO2	1	-
CO3	2	-
CO4	2	-
CO5	3	1
CO5	3	1
CO6	2	1

UNIT-I

Materials for Repair and Rehabilitation:

Admixtures- types of admixtures- purposes of using admixtures- chemical composition- Natural admixtures- Fibers- wraps- Glass and Carbon fiber wraps- Steel Plates-Non destructive evaluation: Importance- Concrete behavior under corrosion, disintegrated mechanisms- moisture effects and thermal effects – Visual investigation- Acoustical emission methods- Corrosion activity measurement- chloride content – Depth of carbonation- Impact echo methods- Ultrasound

pulse velocity methods- Pull out tests.

UNIT-II

Strengthening and Stabilization:

Techniques- design considerations-Beam shear capacity strengthening- Shear Transfer strengthening-stress reduction techniques- Column strengthening-flexural strengthening- Connection stabilization and strengthening, Crack stabilization.

UNIT-III

Bonded Installation Techniques:

Externally bonded FRP- Wet layup sheet, bolted plate, near surface mounted FRP, fundamental debonding mechanisms-intermediate crack debonding- CDC debonding- plate end debonding- strengthening of floor of structures.

UNIT-IV

Fibre Reinforced Concrete:

Properties of constituent materials- Mix proportions, mixing and casting methods-Mechanical properties of fibre reinforced concrete- applications of fibre reinforced concretes-Light weight concrete- properties of light weight concrete- No fines concrete- design of light weight concrete- Flyash concrete- Introduction- classification of flyash- properties and reaction mechanism of flyash- Properties of fly ash concrete in fresh state and hardened state- Durability of flyash concretes.

UNIT-V

High Performance Concrete:

Introduction- Development of high performance concretes- Materials of high performance concretes- Properties of high performance concretes- Self Consolidating concrete-properties- qualifications.

Text Books:

1. Concrete repair and maintenance illustrated-Peter Emmons, published by Brandon W. Emmons.2002. **ISBN:** 978-0876291916
2. Experimental Techniques and Instrumentation, Dr.M.Sreenivasa Reddy, Dr.S.Govindarajan and Dr.S.Pachaiappan, Charulatha Publications, 2022.

Reference Books:

1. Rehabilitation of Concrete Structures, Dr. B. Vidivelli, Standard Publishers Distributors.2009. **ISBN:** 978-8180140276
2. Concrete technology, M S Shetty, S. Chand Publications.2019. **ISBN:** 978-8121900034
3. Concrete technology, Neville & Brooks, pearson education ltd.2019.
ISBN: 978-8131708384

Web Links:

1. <http://nptel.ac.in/courses/112101095/38>
2. <http://www.nptel.ac.in/courses/105105041/module%206.pdf>

NEURAL NETWORKS AND FUZZY LOGIC

Course Code: 242EE028

L	T	P	C
3	0	0	3

Course Outcomes:

At the end of the Course, Student will be able to:

- CO 1: Explain artificial neuron models.
- CO 2: Explain various learning methods of ANN.
- CO 3: Apply different algorithms of ANN.
- CO 4: Distinguish between Classical and Fuzzy Sets.
- CO 5: Apply application of fuzzy logic control to real time systems.

Mapping of Course Outcomes with Program Outcomes:

CO/PO	PO1	PO2	PO3	PO4	PO5	PO6
CO1	3	-	1	1	-	-
CO2	3	-	1	1	-	-
CO3	3	-	1	1	-	-
CO4	3	-	1	1	-	-
CO5	3	-	1	1	-	-

Mapping of Course Outcomes with Program Specific Outcomes:

CO/PSO	PSO1	PSO2
CO1	-	-
CO2	-	-
CO3	-	-
CO4	-	-
CO5	-	-

UNIT-I: Introduction to Neural Networks

Introduction, Humans and Computers, Organization of the Brain, Biological Neuron, Biological and Artificial Neuron Models, Hodgkin-Huxley Neuron Model, Integrate-and Fire Neuron Model, Spiking Neuron Model, Characteristics of ANN, McCulloch-Pitts Model, Applications of ANN.

UNIT-II: Essentials of Artificial Neural Networks

Artificial Neuron Model, Operations of Artificial Neuron, Types of Neuron Activation Function, ANN Architectures, Classification Taxonomy of ANN, Connectivity, Neural Dynamics (Activation and Synaptic), Learning Strategy (Supervised, Unsupervised, Reinforcement), Learning Rules, Types of Application.

UNIT-III: Multilayer feed forward Neural Networks

Credit Assignment Problem, Generalized Delta Rule, Derivation of Back propagation (BP) Training, Summary of Backpropagation Algorithm, Kolmogorov Theorem, Learning Difficulties and Improvements, Radial Basis Function (RBF) Neural Network – Kohonen Self Organising feature Map (KSOM).

UNIT-IV: Classical & Fuzzy Sets

Introduction to classical sets - properties, Operations and relations; Fuzzy sets, Membership, Uncertainty, Operations, properties, fuzzy relations, cardinalities, membership functions.

UNIT-V: Fuzzy Logic Modules

Fuzzification, Membership value assignment, development of rule base and decision making system, Defuzzification to crisp sets, Defuzzification methods.

Text Books:

1. Neural Networks, Fuzzy logic, Genetic algorithms: synthesis and applications by Rajasekharan and Rai – PHI Publication. (ISBN: 9788120353343)
2. Introduction to Neural Networks using MATLAB 6.0 - S.N.Sivanandam, S.Sumathi, S.N.Deepa, TMH. (ISBN: 9780070591127)

Reference Books:

1. Neural Networks, James A Freeman and Davis Skapura, Pearson Education. (ISBN: 9780201513769)
2. Fuzzy sets University and information, J.Klin and T.A.Folger, Prentice Hall. (ISBN: 9789353065782)
3. Introduction to artificial neural systems, J.M.Zurada, Jaico Publication house.(ISBN: 9780314933911)

Web Links:

1. <http://nptel.ac.in/courses/108104049/16>
2. www.archive.nptel.ac.in/courses/127/105/127105006/
3. www.geeksforgeeks.org/fuzzy-logic-introduction/

HYBRID ELECTRIC VEHICLES

Course Code: 242EE029

L	T	P	C
3	0	0	3

Course Outcomes:

At the end of the Course, Student will be able to:

- CO 1: Analyze the architectures of HEVs with various components.
- CO 2: Illustrate the concept of Electric Vehicle and Hybrid Electric Vehicles.
- CO 3: Explain the Plan concept of Plug-in Electrical Vehicles.
- CO 4: Analyze the power electronics converters for HEVs.
- CO 5: Apply various energy storage technologies in Hybrid Vehicles.

Mapping of Course Outcomes with Program Outcomes:

CO/PO	PO1	PO2	PO3	PO4	PO5	PO6
CO1	1	-	3	2	-	-
CO2	1	-	3	2	-	-
CO3	1	-	3	2	-	-
CO4	1	-	3	2	-	-
CO5	1	-	3	2	-	-

Mapping of Course Outcomes with Program Specific Outcomes:

CO/PSO	PSO1	PSO2
CO1	-	-
CO2	-	-
CO3	-	-
CO4	-	-
CO5	-	-

UNIT-I: Introduction

Introduction to Electric Vehicles: History of electric vehicles, social and environmental importance of electric vehicles, impact of modern drive-trains on energy supplies-Challenges and Key Technologies of EVs – Challenges for EV Industry in India

UNIT-II:

Fundamentals of vehicle, components of conventional vehicle and propulsion load, Drive cycles and drive terrain, Concept of electric vehicle and hybrid electric vehicle, Plug-in hybrid vehicle, constituents of PHEV, comparison of HEV and PHEV; Fuel Cell vehicles and its constituents.

UNIT-III: Plug-in Hybrid Electric Vehicle

PHEVs and EREVs, PHEV Architectures, equivalent electric range of blended PHEVs, Fuel economy and power management of PHEVs, end-of-life battery for electric power grid support, vehicle to grid technology, battery charging.

UNIT-IV: Power Electronics in HEVs

Rectifiers and Buck converter used in HEVs, isolated and non-isolated bidirectional DC-DC converter, regenerative braking, voltage source inverter, current source inverter, PWM rectifier in HEVs, EV and PHEV battery chargers.

UNIT-V: Battery and Storage Systems:

Energy Storage Parameters; Lead–Acid Batteries; Ultra capacitors; Flywheels - Superconducting Magnetic Storage System; Pumped Hydroelectric Energy Storage; Compressed Air Energy Storage - Storage Heat; Energy Storage as an Economic Resource.

Text Books:

1. Advanced Electric Drive Vehicles, Ali Emadi, CRC Press.(ISBN: 9781138072855)
2. Electric and Hybrid Vehicles: Design Fundamentals, Iqbal Hussein, CRC Press. (ISBN: 9780367693930)

Reference Books:

1. Introduction to Hybrid Vehicle System Modeling and Control, Wei Liu, Wiley.(ISBN: 9788126556205)
2. Electric and Hybrid Vehicles Technologies, Modelling and Control: A Mechatronic Approach”, Amir Khajepour, Saber Fallahand Avesta Goodarzi, John Wiley & Sons Ltd. (ISBN: 9781118341513)

Web Links:

- 1 <https://archive.nptel.ac.in/courses/108/103/108103009/>
- 2 https://ndl.iitkgp.ac.in/he_document/nptel/nptel/IN_N_1_E_E_12391_I_t_H_a_E_V_1_402_4_D_o_H_E_v_14030_14031

GREEN ENGINEERING SYSTEMS

Course Code: 242ME029

L	T	P	C
3	0	0	3

Course Outcomes: At the end of the Course, Student will be able to:

- CO1:** Distinguish the various solar energy collection methods and measuring instruments.
- CO2:** Explain the different methods of solar energy storage and their applications.
- CO3:** Illustrate the various types of wind mills and performance characteristics.
- CO4:** Explain the principle of Biomass production, Geothermal energy sources and Ocean thermal energy conversion
- CO5:** Illustrate the various types of electrical systems and mechanical systems.
- CO6:** Compare the various energy efficient process.

Mapping of Course Outcomes with Program Outcomes:

	PO 1	PO 2	PO 3	PO 4	PO 5	PO 6
CO1	2	1	1	1	-	-
CO2	2	2	1	1	-	-
CO3	2	2	2	1	-	-
CO4	2	1	-	1	-	-
CO5	2	1	-	1	-	-
CO6	2	1	-	1	-	-

Mapping of Course Outcomes with Program Specific Outcomes:

	PSO1	PSO2
CO1	-	3
CO2	-	3
CO3	-	3
CO4	-	3
CO5	-	3
CO6	-	3

UNIT – I

Introduction: Solar Radiation: Role and potential of new and renewable sources, the solar energy option, Environmental impact of solar power, structure of the sun, the solar constant, sun-earth relationships, coordinate systems of the sun, extraterrestrial and terrestrial solar radiation, solar radiation on tilted surface, instruments for measuring solar radiation and sun shine, solar radiation data, numerical problems. Photo voltaic energy conversion – types of PV cells, I-V characteristics

Solar Energy Collection: Flat plate and concentrating collectors, classification of concentrating collectors, orientation and thermal analysis, advanced collectors.

UNIT – II

Solar Energy Storage and Applications: Different methods, sensible, latent heat and stratified storage, solar ponds, solar applications- solar heating/cooling technique, solar distillation and drying, solar cookers, central power tower concept and solar chimney.

Wind Energy: Sources and potentials, horizontal and vertical axis windmills, performance characteristics, betz criteria, types of winds, wind data measurement.

UNIT – III

Bio-Mass: Principles of bio-conversion, anaerobic/aerobic digestion, types of bio-gas digesters, gas yield, combustion characteristics of bio-gas, utilization for cooking, bio fuels, I.C. engine operation and economic aspects.

Geothermal Energy: Resources, types of wells, methods of harnessing the energy, potential in India.

Ocean Energy: OTEC, Principles of utilization, setting of OTEC plants, thermodynamic cycles. Tidal and wave energy: Potential and conversion techniques, mini-hydel power plants, and their economics.

UNIT – IV

Electrical Systems: Energy efficient motors, energy efficient lighting and control, selection of luminaire, variable voltage variable frequency drives (adjustable speed drives), controls for HVAC (heating, ventilation and air conditioning), demand site management.

Mechanical Systems: Fuel cells- principle, thermodynamic aspects, selection of fuels & working of various types of fuel cells, Environmentally friendly and Energy efficient compressors and pumps.

UNIT – V

Energy Efficient Processes: Environmental impact of the current manufacturing practices and systems, benefits of green manufacturing systems, selection of recyclable and environment friendly materials in manufacturing, design and implementation of efficient and sustainable green production systems with examples like environmentally friendly machining, vegetable based cutting fluids, alternate casting and joining techniques, zero waste manufacturing.

Green Buildings: Definition, features and benefits. Sustainable site selection and planning of building for maximum comfort. Environmentally friendly building materials like bamboo, timber, rammed earth, hollow blocks, lime & lime pozzolana cement, agro materials and industrial waste.

Text Books:

- 1 Solar Energy – Principles of Thermal Collection and Storage/Sukhatme S.P. and J.K. Nayak/ TMH.
- 2 Non-Conventional Energy Resources/ Khan B.H/ Tata McGraw Hill, New Delhi,

Reference Books:

- 1 Renewable Energy Technologies /Ramesh & Kumar /Narosa.
- 2 Renewable Energy Resources-2 Edition/ J. Twidell and T. Weir/ BSP Books Pvt. Ltd.

Web Links:

- 1 https://onlinecourses.nptel.ac.in/noc17_me33
- 2 <https://nptel.ac.in/courses/105107176/20>

I.C.ENGINES

Course Code: 242ME030

L	T	P	C
3	0	0	3

Course Outcomes:

At the end of the Course, Student will be able to:

- CO1: Summarize the finite element methods
- CO2: Analyse one-dimensional problems in trusses and beams
- CO3: Solve structural problems using CST and axis - symmetric formulation
- CO4: Apply finite elements to higher order, Iso-parametric elements, and one-dimensional heat transfer analysis.
- CO5: Apply finite element methods to dynamic analysis.

Mapping of Course Outcomes with Program Outcomes:

CO/PO	PO 1	PO 2	PO 3	PO 4	PO 5	PO 6
CO1	2	1	1	1	-	-
CO2	2	2	1	1	-	-
CO3	2	2	2	1	-	-
CO4	2	1	-	1	-	-
CO5	2	1	-	1	-	-

Mapping of Course Outcomes with Program Specific Outcomes:

CO/PSO	PSO1	PSO2
CO1	-	-
CO2	-	-
CO3	-	-
CO4	-	-
CO5	-	-

UNIT – I: Gas Exchange Processes

Inlet and exhaust processes in the four stroke cycle volumetric efficiency quasi static effects combined quasi static and dynamic effects variation with speed and valve area and timing-flow through valves poppet valve geometry and timing flow rate and discharge efficient, residual gas fraction exhaust gas flow rate and temperature variation, scavenging in wnike eyelid engines, scavenging parameters and mdeluctual scavenging processes. Flow through parts supercharging and turbo changing methods of power buying abusive relationships compressors, turbines wave compression devices.

UNIT – II: Charge Motion Within The Cylinder

Intake Jet Flow, Mean velocity and turbulence characteristics definitions application to engine velocity data swirl swirl measurement, swirl generation during induction swirl modification within the cylinder squish pre chamber engine flow crevice flows and blowby generated by piston-cylinder wall interaction

UNIT – III: Combustion In S.I And C.I Engines

Review of normal and abnormal combustion in SI and CI engine cyclic variation in combustion of SI engine analysis of cylindrical pressure data in SI and CI engine. EMP Flex SI engines common rail fuel injection system in CI engines fuel spray behavior in CI engine

UNIT – IV: Electric Vehicles

Introduction Limitations of IC Engines as prime mover. History of EV, EVem. components of V. and AC electric machines: Introduction and basic structure, Electric vehicle drive train, advantages and limitations Permanent magnet and switched reluctance motors.

UNIT – V: Hybrid Vehicles

Configurations of hybrid, Series and parallel, advantages and limitations, Hybrid drive trains, sizing of components Initial acceleration, rated vehicle velocity, Maximum velocity and maximum gradeability, Hydrogen: Production, Hydrogen storage systems, reformers.

Fuel Cell Vehicles: Introduction, Fuel cell characteristics, Thermodynamics of Fuel cells, Fuel cell types; emphasis on PEM fuel cell.

Text Books:

- 1 Internal Combustion Engine Fundamentals, J.B. Heywood, Mc Graw Hill Co, (ISBN: 978-1259002076)
- 2 Build your own electric vehicle, Seth Leitman and Bob Brant. McGraw Hill, Co, 3 rd edition, (ISBN: 978-0071770569)

Reference Books:

- 1 Engineering Fundamentals of IC Engine, H.N. Gupta, 2nd edition PHI Pvt. Ltd. (ISBN: 9788120346802)
- 2 PEM Fuel Cells-Theory and Practice, F. Barbir Elsevier Academic Press, (ISBN: 9780128102398)

Web Links:

- 1 <http://nptel.ac.in/courses/112101097/>
- 2 www.thermopedia.com/content/786

CAD TOOLS FOR VLSI DESIGN

Course Code:242EC028

L	T	P	C
3	0	0	3

Course Outcomes:

At the end of the Course, Student will be able to:

- CO1: Comprehend the insight of CAD Tools in modern design.
- CO2: Develop combinational logic circuits by using CAD tools
- CO3: Build sequential logic circuits using Verilog HDL operators
- CO4: Analyze the performance of logic schematics using CAD simulation tools
- CO5: Infer the performance of logic circuits in terms of DRC, LVS and PEX.

Mapping of Course Outcomes with Program Outcomes:

CO/PO	PO 1	PO 2	PO 3	PO 4	PO 5	PO 6
CO1	1	3	1	2	2	1
CO2	2	3	1	2	1	2
CO3	2	2	3	2	2	1
CO4	2	3	1	2	2	1
CO5	2	3	2	2	2	1

Mapping of Course Outcomes with Program Specific Outcomes:

CO/PSO	PSO1	PSO2	PSO3
CO1	2	3	1
CO2	2	3	1
CO3	2	3	1
CO4	2	3	1
CO5	2	3	1

UNIT – I

Understanding the working platform with Xilinx Vivado and its device, family and package Selection. Design and Implementation of Combinational Circuits Priority Encoder and Comparator using data flow & structural style.

UNIT – II

Design and Implementation of Sequential Circuits to detect a given sequence using with and without overlapping (mealy & Moore machines). Design and Implementation of a traffic light controller in three road & four road junctions.

UNIT – III

Exercise on Concatenation, Replication operators, Reduction and Conditional operators in Verilog HDL. Performance characteristics of an n-channel and p-channel MOSFET.

UNIT – IV

Working with Schematic for Ring Oscillator with variable amounts of Pull up to pull down ratios. Design a full adder by instantiating the logic gates. Make a comment on design style on its performance.

UNIT – V

Design a NAND gate by using NMOS, PMOS and CMOS technologies and make a comment on its performance. Design a Schematic, stick and layout for given logic.

Text Books:

1. S. M. Kang and Y. Leblebici, CMOS Digital Integrated Circuits : Analysis and Design, Third Edition, MH, (ISBN Number-0072460539)
2. Plummer, Deal , Griffin “Silicon VLSI Technology: Fundamentals, Practice & Modeling”PH, (ISBN Number-0130850373)

Reference Books:

1. P. VanZant , “Microchip Fabrication”, 5th Edition, MH, (ISBN Number-6053901308)
2. R. J. Baker, H. W. Li and D. E. Boyce, CMOS Circuit Design, Layout and Simulation, PH, (ISBN Number-1119481511)

Web Links:

1. <https://themosisservice.com/university-support>
2. <https://youtu.be/OF3Zwfu6Ngc>
3. <https://newsroom.ibm.com/2021-05-06-IBM-Unveils-Worlds-First-2->

FPGA DESIGN FOR EMBEDDED SYSTEMS

Course Code: 242EC029

L	T	P	C
3	0	0	3

Course Outcomes:

At the end of the Course, Student will be able to:

- CO1:** Outline the concepts of Embedded System and Hardware Description Languages
- CO2:** Develop an embedded system using FPGA
- CO3:** Explain FPGA platforms and cross development tools.
- CO4:** Illustrate Parallelism and scheduling concepts
- CO5:** Interpret the parallelism with in FPGA hardware core.

Mapping of Course Outcomes with Program Outcomes:

CO/PO	PO 1	PO 2	PO 3	PO 4	PO 5	PO 6
CO1	1	1	3	1	-	-
CO2	3	-	2	-	-	-
CO3	1	-	2	3	-	-
CO4	1	-	2	3	-	-
CO5	1	-	2	3	-	-

Mapping of Course Outcomes with Program Specific Outcomes:

CO/PSO	PSO1	PSO2	PSO3
CO1	1	2	-
CO2	-	2	2
CO3	-	2	2
CO4	2	-	2
CO5	2	-	2

UNIT – I: Embedded System Overview & Hardware Description Languages

H/W-FPGA-Embedded SoC and use of VLSI circuit technology-platform FPGA’s-Altera, Cyclone, Hardware Description Languages - VHDL , Verilog , Other High-Level HDLs, From HDL to Configuration Bit-stream

UNIT – II: System Design using FPGA:

Principles of system design-Design quality, Modules and interfaces, Abstraction and state, Cohesion and coupling, Designing and Reuse, Control flow graph, Design-Origins of platform FPGA designs.

UNIT – III: FPGA Platform

Components, adding to platform FPGA systems, assembling custom compute cores. Software Design-System Software Options, Root File system, Cross-Development Tools, Monitors and Boot-loader.

UNIT – IV: Partitioning, Scheduling & Communication

Overview of Partitioning Problem, Analytical Solution to Partitioning-Basic definitions, expected performance gain, resource considerations, Analytical Approach, Communication-Invocation/Coordination, Transfer of State, Practical Issues- Profiling Issues, Data Structures Manipulate Feature Size.

UNIT – V: Spatial Design

Principles of Parallelism-Identifying Parallelism - Spatial Parallelism with Platform FPGAs Parallelism within FPGA Hardware Cores, Parallelism within FPGA Designs

Text Books:

1. Embedded Systems Design with Platform FPGAs, Ron Sass, Andrew G Schmidt Principles and Practices, First Edition, Tata McGraw Hill, India, ISBN Number-0123743338
2. Digital Systems design using VHDL, Charles H Roth. Jr, Re-Print, PWS publishing company (Thomson Books), USA, ISBN Number-9788131518304

Reference Books:

1. Design with VHDL, V A. Padroni Circuit First Edition, MIT Press Cambridge, England, ISBN Number-0262162245
2. FPGA Based System Design, Wayne Wolf, First Edition, Prentices Hall Modern Semiconductor Design Series, USA, ISBN Number-0131424610

Web Links:

1. <https://www.coursera.org/learn/intro-fpga-design-embedded-systems>
2. <https://www.colorado.edu/ali/fpga-design-embedded-systems-specialization>

ARTIFICIAL INTELLIGENCE

Course Code: 242CS030

L	T	P	C
3	0	0	3

Course Outcomes:

At the end of the Course, Student will be able to:

- CO 1: Describe fundamentals of Artificial Intelligence and its applications
- CO 2: Solve basic AI based problems and construct logical building blocks for problem Formulation
- CO 3: Apply various logical systems inferencing different logical problems.
- CO 4: Illustrate knowledge representation using predicate logic and predicate rules.
- CO 5: Design expert systems that leverage domain knowledge effectively.

Mapping of Course Outcomes with Program Outcomes:

CO/PO	PO1	PO2	PO3	PO4	PO5	PO6
CO1	2	1	-	-	1	-
CO2	2	1	2	-	1	-
CO3	2	1	2	2	1	2
CO4	2	1	2	-	1	-
CO5	2	1	-	-	1	-

Mapping of Course Outcomes with Program Specific Outcomes:

CO/PSO	PSO1	PSO2
CO1	-	-
CO2	-	-
CO3	-	-
CO4	-	-
CO5	-	-

UNIT – I: Introduction to Artificial Intelligence:

Introduction, History, Intelligent Systems, Foundations of AI, Applications, Tic-Tac-Toe Game playing, Development of AI Languages, Current trends in AI

UNIT – II: Problem Solving: State-Space Search and Control Strategies:

Introduction, General Problem Solving, Characteristics of problem, Exhaustive Searches, Heuristic Search Techniques, Iterative- Deepening A*, Constraint Satisfaction.

Problem Reduction and Game Playing: Problem Reduction, Game Playing, Minimax algorithm, Alpha- Beta Pruning, Two-player perfect information games.

UNIT – III: Logic Concepts

Introduction, Propositional calculus, Propositional logic, Representing facts in logic, functions and predicates, Axiomatic System, Semantic Tableau System in Propositional logic, Resolution Refutation in propositional logic, predicate logic.

UNIT – IV: Knowledge Representation

Knowledge Representation Using Predicate logic, Knowledge Representation using Semantic Network, Knowledge Representation using Frames.

Representing Knowledge Using Rules: Procedural Versus Declarative knowledge, Logic Programming, Forward versus Backward Reasoning

UNIT – V: Expert System

Representing and using Domain Knowledge, Reasoning with knowledge, Expert System Shells, Support for explanation examples, Knowledge acquisition-examples.

Text Books:

1. Artificial Intelligence- Saroj Kaushik, 1st edition CENGAGE Learning, (ISBN: 9789355730428).
2. Artificial intelligence, A modern Approach, Stuart Russel, Peter Norvig, Pearson Education Ltd, 2nd ed, (ISBN: 97881203238)
3. Artificial Intelligence- Elaine Rich, Kevin Knight, Shivashankar B Nair, 3rd ed, McGraw Hill Education, (ISBN-13. 9780070087705)

Reference Books:

1. Artificial intelligence structures and strategies for complex problem solving, George F Lugar, 5th Edition, Addison Wesley. ISBN-13: 978-0321263186

Web Links:

1. https://www.tutorialspoint.com/artificial_intelligence/index.htm/
2. <https://www.slideshare.net/slideshow/logic-in-ai/5005940/> _
3. <https://www.slideshare.net/slideshow/artificial-intelligence-3638681/3638681/>

MACHINE LEARNING TECHNIQUES

Course Code: 242CS031

L	T	P	C
3	0	0	3

Course Outcomes:

At the end of the Course, Student will be able to:

- CO1: Describe the need for AI and ML, and the types of ML algorithms..
- CO2: Apply regression techniques and dimensionality reduction methods.
- CO3: Implement and evaluate various classification techniques.
- CO4: Describe and implement Artificial Neural Networks.
- CO5: Utilize unsupervised learning methods for clustering and dimensionality reduction

Mapping of Course Outcomes with Program Outcomes:

CO/PO	PO1	PO2	PO3	PO4	PO5	PO6
CO1	2	1	-	-	-	-
CO2	2	1	2	-	-	-
CO3	2	1	2	2	-	2
CO4	2	1	2	-	-	-
CO5	2	1	-	-	-	-

Mapping of Course Outcomes with Program Specific Outcomes:

CO/PSO	PSO1	PSO2
CO1	-	-
CO2	-	-
CO3	-	-
CO4	-	-
CO5	-	-

UNIT – I

Introduction: Understanding the need for AI and Machine Learning (ML), AI & Data, Types of ML Algorithms: Supervised, Unsupervised Learning and semi supervised learning, reinforcement learning, evolutionary computation ML Model development life cycle Deep Learning for Human Like Learning

UNIT – II

Regression Techniques: Regression for prediction, Gradient Descent and Ascent, Learning

with Momentum, Loss Functions, Over fitting and under fitting, Model evaluation techniques
Types of Regression: Linear Regression,

UNIT – III

Classification Techniques: Naïve Bayes Classification: Bayesian Learning, Naïve Bayes Classification, MAP, Bayesian Belief Networks, Decision Tree, K-Nearest Neighbors Support Vector Machines: Hard Margin and Soft Margin, Kernels and Kernel Trick, Evaluation Measures for Classification Techniques

UNIT – IV

Classification Techniques: Naïve Bayes Classification: Bayesian Learning, Naïve Bayes Classification, MAP, Bayesian Belief Networks Decision Tree K-Nearest Neighbors Support Vector Machines: Hard Margin and Soft Margin, Kernels and Kernel Trick, Evaluation Measures for Classification Techniques

UNIT – V

Unsupervised Learning: Uses in Clustering, associations and dimensionality reduction
Clustering, Hierarchical Agglomerative Clustering, k-means Algorithm

Text Books:

- 1 Machine Learning, Tom Mitchell, McGraw-Hill international editions, TMH, (ISBN: 0071154671)
- 2 Pattern Recognition and Machine Learning C. Bishop, Springer, (ISBN: 9781493938438)
- 3 Elements of Artificial Neural Networks , Kishan Mehrotra, Chilukuri Mohan and Sanjay Ranka, Penram International, (ISBN: 9780262133289).

Reference Books:

- 1 Pattern Recognition, Techniques and Applications , Rajjan Shinghal, OXFORD Higher Education , (ISBN:9780195676853)
- 2 Andrew Kelleher, Adam Kelleher, Applied Machine Learning for Data Scientist and Software engineers, Addison-Wesley Professional, (ISBN:9780134116549)

Web Links:

- 1 https://onlinecourses.nptel.ac.in/noc21_cs24/preview/
- 2 <https://www.udemy.com/course/machinelearning/>

VALUE EDUCATION

Course Code: 242AC001

L	T	P	C
3	0	0	3

Course Outcomes:

At the end of the Course, Student will be able to:

- CO 1: Understand value of education and self- development.
- CO 2: Explain the need of good values in students.
- CO 3: Developing the overall personality.
- CO 4: Explain the need of character in a student.

Mapping of Course Outcomes with Program Outcomes:

CO/PO	PO1	PO2	PO3	PO4	PO5	PO6
CO1	2	1	-	-	2	-
CO2	3	2	1	1	3	-
CO3	3	3	2	2	2	-
CO4	2	1	1	1	2	-
CO5	3	2	2	2	2	-

Mapping of Course Outcomes with Program Specific Outcomes:

CO/PSO	PSO1	PSO2
CO1	-	-
CO2	-	-
CO3	-	-
CO4	-	-
CO5	-	-

UNIT – I

Values and self-development –Social values and individual attitudes. Work ethics, Indian vision of humanism, Moral and non- moral valuation. Standards and principles, Value judgements.

UNIT – II

Importance of cultivation of values, Sense of duty, Devotion, Self-reliance, Confidence, Concentration. Truthfulness, Cleanliness, Honesty, Humanity. Power of faith, National Unity, Patriotism. Love for nature, Discipline

UNIT – III

Personality and Behavior Development - Soul and Scientific attitude. Positive Thinking. Integrity and discipline, Punctuality, Love and Kindness, Avoid fault Thinking, Free from anger, Dignity of labour, Universal brotherhood and religious tolerance, True friendship.

UNIT – IV

Happiness Vs suffering, love for truth, Aware of self- destructive habits, Association and Cooperation, Doing best for saving nature.

UNIT – V

Character and Competence -Holy books vs Blind faith, Self-management and Good health, Science of reincarnation, Equality, Nonviolence, Humility, Role of Women, All religions and same message, Mind your Mind, Self-control, Honesty, Studying effectively.

Text Books:

1. Chak ro borty, S.K. “Values and Ethics for organizations Theory and practice”, Oxford University Press, New Delhi. (ISBN: 9780195643077)

Reference Books:

1. Value Education and Professional Ethics by R.P. Shukla **ISBN:** 978-8183560995
2. Value Education: A Textbook for Schools by Dr. N. Venkataiah **ISBN:** 978-8120731965
3. Value Education: Theory and Practice by G. Rajagopal **ISBN:** 978-8182475191

Web Links:

1. <https://nptel.ac.in/courses/109/104/109104068/>
2. <https://nptel.ac.in/courses/109/105/109105116/>
3. <https://nptel.ac.in/courses/109/104/109104107/>

RESEARCH METHODOLOGY

Course Code: 242AC002

L T P C
3 0 0 3

Course Outcomes:

At the end of the Course, Student will be able to:

- CO 1: Explain the characteristics and process of research.
- CO 2: Choose the research problem by applying problem identification techniques.
- CO 3: Develop and execute research design process.
- CO 4: Show the results of research process adhering to professional ethics.
- CO 5: Analyze the results of research using statistical measures of central tendency & coefficient of variation, correlation and regression

Mapping of Course Outcomes with Program Outcomes:

CO/PO	PO1	PO2	PO3	PO4	PO5	PO6
CO1	2	1	-	-	2	-
CO2	3	2	1	1	3	-
CO3	3	3	2	2	2	-
CO4	2	1	1	1	2	-
CO5	3	2	2	2	2	-

Mapping of Course Outcomes with Program Specific Outcomes:

CO/PSO	PSO1	PSO2
CO1	-	-
CO2	-	-
CO3	-	-
CO4	-	-
CO5	-	-

UNIT – I: Meaning of Research

Function of Research - Characteristics of Research – Steps involved in Research – Research in Pure and Applied Sciences - Inter Disciplinary Research. Factors which hinder Research – Significance of Research - Research and scientific methods – Research Process– Criteria of good Research – Problems encountered by Researchers – Literature review.

UNIT – II: Identification of Research Problem

Selecting the Research problem – Necessity of defining the problem – Goals and Criteria for identifying problems for research. Perception of Research problem – Techniques involved in defining the problem.

UNIT – III: Research Design

Formulation of Research design – Need for Research design – Features of a good design – Important concepts related to Research design.

UNIT – IV: Interpretation and Report Writing

Meaning and Technique of interpretation – Precautions in interpretation, Significance of report writing – Different steps in writing a report – Layout of a Research report.

UNIT – V: Statistical Techniques and Tools

Introduction of statistics – Functions – Limitations – Measures of central tendency - Arithmetic mean – Median – Mode – Standard deviation – Co-efficient of variation (Discrete series and continuous series) – Correlation – Regression.

Text Books:

1. Research Methodology Methods & Techniques, C.R. Kothari – New Age international Publishers (ISBN: 9789386649225).
2. A Hand Book of Methodology of Research, Rajammall, P. Devadoss and K. Kulandaivel, RMMVidyalaya press.(ISBN: 9780367135720)

Reference Books:

1. Thesis and Assignment Writing, J. Anderson, Wiley Eastern Ltd.(ISBN: 9780471339274)
2. Research Methodology, Mukul Gupta, Deepa Gupta – PHI Learning Private Ltd., New Delhi. (ISBN: 9788120343818)
3. Fundamentals of Mathematical statistics, S.C. Gupta and V.K. Kapoor, Sultan Chand & Sons, New Delhi.(ISBN: 9788180545283)

Web Links:

1. <https://nptel.ac.in/courses/127106227>
2. <https://www.coursera.org/learn/research-methodologies>
