

PROGRAM CURRICULUM

POWER ELECTRONICS AND DRIVES

for

M. TECH. TWO YEAR DEGREE PROGRAM

(Applicable for the batches admitted from A.Y 2024-25)



ADITYA UNIVERSITY

Aditya Nagar, ADB Road, Surampalem - 533 437

VISION & MISSION OF THE UNIVERSITY

VISION :

Aditya University aspires to be a globally recognised academic institution dedicated to quality education, cutting-edge research, and technological service to our country, and envisions itself as a beacon of holistic advancement and long-term impact, remaining dynamic in the ever-changing worlds of society, ecology, and economics..

MISSION:

- Aditya University pushes boundaries to design high-quality curricula and to provide students with a vibrant and relevant education that prepares them for a changing world. Our industry insights and creative teaching methods attempt to equip our students to be lifelong learners.
- Aditya University's learning environment encourages intellectual curiosity, critical thinking, and cooperation, with the goal of providing students with an immersive education that fosters creativity and innovation. Our cutting-edge facilities, interactive classrooms, and supportive faculty aim to motivate students to realise their full potential and contribute to society.
- Aditya University promotes cross-disciplinary inquiry and discovery and leads cutting-edge research and innovation. Through strategic partnerships, research grants, and a dedicated faculty, we aim to advance science, technology, and social sciences and empower students and faculty to conduct transformative research that solves real-world problems and elevates our institution globally.
- Aditya University is committed to producing world-changing business leaders and entrepreneurs through its emphasis on entrepreneurship, mentoring, and business incubation programmes.

VISION & MISSION OF THE DEPARTMENT

Vision:

To be a pioneer in the field of Electrical Engineering competing globally with quality education and frontier research to progress sustainable development in industry and society.

Mission:

- M 1: To develop technocrats by imparting quality education to fulfil industry and society demands.
- M 2: To provide an amiable environment and nurture individuals for excellence in research, innovation, and leadership.
- M 3: To encourage students to become responsible citizens and inculcate value based professional ethics in the pursuit of holistic growth.
- M 4: To bridge the gap between academics and industries by developing relevant curricula and syllabuses.

PROGRAM OUTCOMES (POs)

After successful completion of the program, the graduates will be able to

PO 1	Independently carry out research /investigation and development work to solve practical problems
PO 2	Write and present a substantial technical report/document
PO 3	Demonstrate a degree of mastery over the area as per the specialization of the program. The mastery should be at a level higher than the requirements in the appropriate bachelor program.
PO 4	Learn, keep up with contemporary technologies and ways of working.
PO 5	Communicate effectively as an individual or a team leader in diverse and multidisciplinary groups.
PO 6	Use the principles of project management such as scheduling, work breakdown structure and be conversant with the principles of finance for profitable project management.

PROGRAM SPECIFIC OUTCOMES (PSO's)

After successful completion of the program, the graduates will be able to

PSO 1	Apply technical knowledge on cutting-edge technologies to design and develop power electronic converters and drives.
PSO 2	Apply contemporary computing techniques to assess a wide range of issues in a social and environmental setting.

PROGRAM EDUCATIONAL OBJECTIVES (PEOs)

Graduates of the Program will

PEO 1	Inculcate the ability to evaluate, analyze, and solve evolving challenges in the domain of Power Electronics and Drive systems.
PEO 2	Inculcate the ability to evaluate, analyze, and solve evolving challenges in the domain of Power Electronics and Drive systems.
PEO 3	To Engage in collaborative teamwork's with ethics in their research and professional achievements.



ADITYA UNIVERSITY

Department of Electrical and Electronics Engineering

Master of Technology in Power Electronics and Drives

Program Curriculum - 2024

Credit Division:

S. No.	Category of Course	Credits
1	Program Core Courses (PCC)	30
2	Program Elective Courses (PEC)	15
3	University Elective Courses (UEC)	03
4	Summer Internship (SI)	02
5	Technical Paper Publication (TPP)	02
6	Project Part-I & Project Part-II (PROJ)	28
7	Audit Courses (AUC)	0
Total Credits		80

Program Core Courses (PCC):

Course Code	Course Title	L	T	P	C	CIE	SEE	Total	Pre-requisite
242EE001	Power Electronic Converters	3	0	1	4	50	50	100	-
242EE002	Electrical Drives	3	0	2	5	50	50	100	-
242EE003	Electrical Machine Modeling and Analysis	3	0	0	3	50	50	100	-
242EE004	Reactive Power Compensation and Management	3	0	0	3	50	50	100	-
242EE005	Advanced Power Electronic Converters	3	0	1	4	50	50	100	PEC
242EE006	Intelligent Control Techniques in Electric Drives	3	0	2	5	50	50	100	ED
242EE007	Smart Grid Technologies	3	0	0	3	50	50	100	PEC
242EE008	Energy Storage Technologies	3	0	0	3	50	50	100	-

Program Elective Courses (PEC):

Course Code	Course Title	L	T	P	C	CIE	SEE	Total	Pre-requisite
242EE009	Renewable Energy Technologies	3	0	0	3	50	50	100	-
242EE010	HVDC Transmission and Flexible AC Transmission Systems	3	0	0	3	50	50	100	PEC
242EE011	Embedded Systems for Power Electronics	3	0	0	3	50	50	100	-
242EE012	Programmable Logic Controllers and Applications	3	0	0	3	50	50	100	-
242EE013	Digital Signal Processing Controlled Drives	3	0	0	3	50	50	100	-
242EE014	Power Converter Technologies	3	0	0	3	50	50	100	-
242EE015	Switched Mode Power Conversion	3	0	0	3	50	50	100	APEC
242EE016	Control and Integration of Renewable Energy Systems	3	0	0	3	50	50	100	RET
242EE017	Modern Control Theory	3	0	0	3	50	50	100	-
242EE018	Power Quality and Custom Power Devices	3	0	0	3	50	50	100	HVDC& FACTS
242EE019	Digital Control Systems	3	0	0	3	50	50	100	MCT
242EE020	Advanced Digital Signal Processing	3	0	0	3	50	50	100	DSPCD
242EE021	Electric Vehicles and Drives	3	0	0	3	50	50	100	ED
242EE022	Modeling and Simulation of Power Electronic Systems	3	0	0	3	50	50	100	-
242EE023	Advanced Control systems	3	0	0	3	50	50	100	DCS

University Elective Courses (UEC):

Course Code	Course Name	L	T	P	C	CIE	SEE	Total	Offered to PG Program	Pre-requisite
242CE028	Metro Rail Transportation Design and Construction (L&T EduTech)**	3	0	0	3	50	50	100	All, except SE	-
242CE029	Building Information Modeling in Architecture, Engineering and Construction (L&T EduTech)**	3	0	0	3	50	50	100	All, except SE	-
242CE030	Basic Concrete Technology	3	0	0	3	50	50	100	All, except SE	-
242CE031	Repair & Rehabilitation of Structures	3	0	0	3	50	50	100	All, except SE	-
242EE028	Neural Networks and Fuzzy Logic	3	0	0	3	50	50	100	All, except PED	-
242EE029	Hybrid Electric Vehicles	3	0	0	3	50	50	100	All, except PED	-
242EE030	Electrical Power Distribution and Automation (L&T EduTech)**	3	0	0	3	50	50	100	All, except PED	-
242EE031	Renewable Energy & Power Evacuation (L&T EduTech)**	3	0	0	3	50	50	100	All, except PED	-
242ME028	Design of fire and life safety systems(L&T EduTech)**	3	0	0	3	50	50	100	All, except TE	-
242ME029	Green Engineering Systems	3	0	0	3	50	50	100	All, except TE	-
242ME030	IC Engines	3	0	0	3	50	50	100	All, except TE	-
242EC028	CAD Tools for VLSI Design	3	0	0	3	50	50	100	All, except VLSID	-
242EC029	FPGA Design for Embedded Systems	3	0	0	3	50	50	100	All, except VLSID	-
242CS030	Artificial Intelligence	3	0	0	3	50	50	100	All, except CSE	-
242CS031	Machine Learning Techniques	3	0	0	3	50	50	100	All, except CSE	-

** The syllabus for the industry partner courses will be released in the department as and when required.

Summer Internship (SI):

Course Code	Course Name	L	T	P	C	CIE	SEE	Total	Pre-requisite
242EE024	Summer Internship			2	2	100	-	100	-

Technical Paper Publication:

Course Code	Course Name	L	T	P	C	CIE	SEE	Total	Pre-requisite
242EE026	Technical Paper Publication			2	2	100	-	100	-

Project Part-I & Project Part-I I (PROJ):

Course Code	Course Name	L	T	P	C	CIE	SEE	Total	Pre-requisite
242EE025	Project Part-I			10	10	100		100	-
242EE027	Project Part-II			18	18	50	50	100	-

Audit Courses (AUC):

Course Code	Course Title	L	T	P	C	CIE	SEE	Total	Pre-requisite
242AC001	Value Education	2			0	100	-	100	-
242AC002	Research Methodology	2			0	100	-	100	-

2024 M.Tech (PE&D) CURRICULUM PRE-REQUISITES FLOW CHART

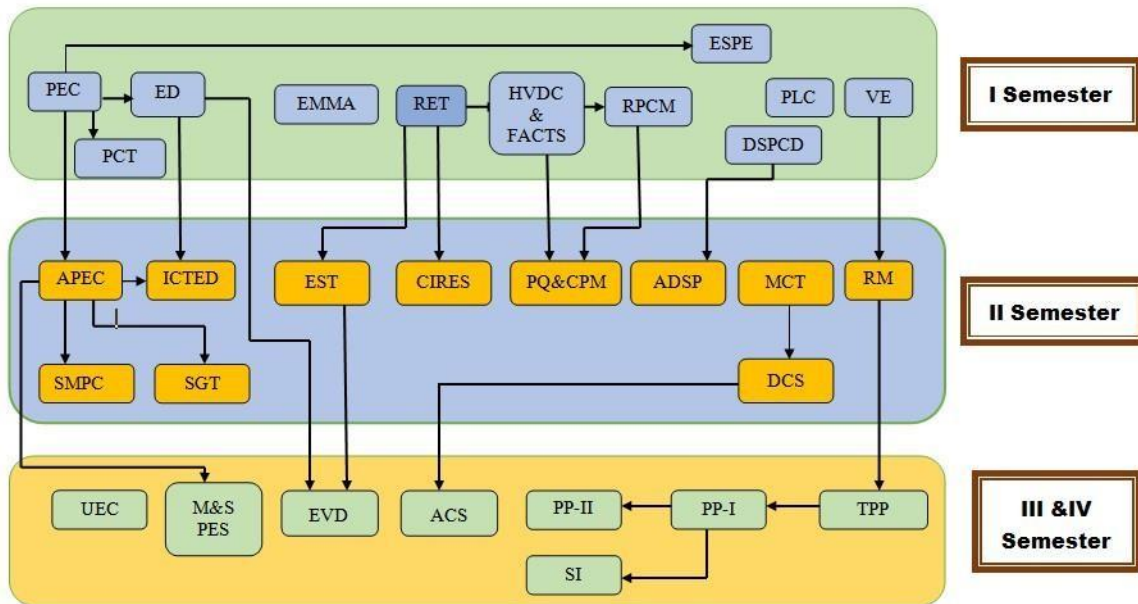

List of Courses	
PEC	Power Electronic Converters
ED	Electrical Drives
EMMA	Electrical Machine Modeling and Analysis
RPCM	Reactive Power Compensation and Management
EMMA	Electrical Machine Modeling and Analysis
RET	Renewable Energy Technologies
HVDC AND FACTS	HVDC Transmission and Flexible AC Transmission Systems
ESPE	Embedded Systems for Power Electronics
PLC	Programmable Logic Controllers and Applications
DSPCD	Digital Signal Processing Controlled Drives
PCT	Power Converter Technologies
APEC	Advanced Power Electronic Converters
ICTED	Intelligent Control Techniques in Electric Drives
SGT	Smart Grid Technologies
EST	Energy Storage Technologies
SMPC	Switched Mode Power Conversion
CIRES	Control and Integration of Renewable Energy Systems
MCT	Modern Control Theory
PQ AND CPD	Power Quality and Custom Power Devices
DCS	Digital Control Systems
ADC	Advanced Digital Signal Processing
IEC	Institute Elective Course
VE	Value Education
RM	Research Methodology
SI	Summer Internship
PP-I	Project Part-I
TPP	Technical Paper Publication
PP-II	Project Part-II

**Suggestive Semester Wise Curriculum
I Semester**

Course code	Course Title	Course Category	Credits				Total Hours
			L	T	P	Total	
242EE001	Power Electronic Converters	PCC	3	0	1	4	4
242EE002	Electrical Drives	PCC	3	0	2	5	7
242EE003	Electrical Machine Modeling and Analysis	PCC	3	0	0	3	3
242EE004	Reactive Power Compensation and Management	PEC	3	0	0	3	3
----	Program Elective Course –I	PEC	3	0	0	3	3
----	Program Elective Course –II	PCC	3	0	0	3	3
242AC001	Value Education	AUC	2	0	0	0	2
Total			20	0	3	21	25

II Semester

Course code	Course Title	Course Category	Credits				Total Hours
			L	T	P	Total	
242EE005	Advanced Power Electronic Converters	PCC	3	0	1	4	4
242EE006	Intelligent Control Techniques in Electric Drives	PCC	3	0	2	5	7
242EE007	Smart Grid Technologies	PCC	3	0	0	3	3
242EE008	Energy Storage Technologies	PEC	3	0	0	3	3
----	Program Elective Course –III	PEC	3	0	0	3	3
----	Program Elective Course –IV	PCC	3	0	0	3	3
242AC002	Research Methodology	AUC	2	0	0	0	2
Total			20	0	3	21	25

III Semester

Course code	Course Title	Course Category	Credits				Total Hours
			L	T	P	Total	
----	Program Elective Course –V	PEC	3	0	0	3	3
----	University Elective Course	UEC	3	0	0	3	3
242EE024	Summer Internship	SI				2	-
242EE025	Project Part-I	PROJ	0	0	10	10	18
Total			0	0	15	18	24

IV Semester

Course code	Course Title	Course Category	Credits				Total Hours
			L	T	P	Total	
242EE026	Technical Paper Publication	TPP	0	0	2	2	6
242EE027	Project Part-II	PROJ	0	0	18	18	34
Total					20	20	40

Program Elective Course-I

S. No.	Course Code	Course Name
1.	242EE009	Renewable Energy Technologies
2.	242EE010	HVDC Transmission and Flexible AC Transmission Systems
3.	242EE011	Embedded Systems for Power Electronics

Program Elective Course-II

S. No.	Course Code	Course Name
1.	242EE012	Programmable Logic Controllers and Applications
2.	242EE013	Digital Signal Processing Controlled Drives
3.	242EE014	Power Converter Technologies

Program Elective Course-III		
S. No.	Course Code	Course Name
1.	242EE015	Switched Mode Power Conversion
2.	242EE016	Control and Integration of Renewable Energy Systems
3.	242EE017	Modern Control Theory

Program Elective Course-IV		
S. No.	Course Code	Course Name
1.	242EE018	Power Quality and Custom Power Devices
2.	242EE019	Digital Control Systems
3.	242EE020	Advanced Digital Signal Processing

Program Elective Course-V		
S. No.	Course Code	Course Name
1.	242EE021	Electric Vehicles & Drives
2.	242EE022	Modelling and Simulation of Power Electronic Systems
3.	242EE023	Advanced Control systems

POWER ELECTRONIC CONVERTERS

Course Code: 242EE001

L	T	P	C
3	0	1	4

Course Outcomes:

At the end of the Course, Student will be able to:

- CO 1: Explain the operation of AC voltage controllers
- CO 2: Illustrate the operation of cycloconverters and matrix converters.
- CO 3: Analyze the performance of controlled converters.
- CO 4: Analyze the operation of different types of DC-DC converters.
- CO 5: Explain the operation of inverters and applications of PWM techniques.

Mapping of Course Outcomes with Program Outcomes:

CO/PO	PO1	PO2	PO3	PO4	PO5	PO6
CO1	2	-	3	1	-	-
CO2	2	-	3	1	-	-
CO3	2	-	3	1	-	-
CO4	2	-	3	1	-	-
CO5	2	-	3	1	-	-

Mapping of Course Outcomes with Program Specific Outcomes:

CO/PSO	PSO1	PSO2
CO1	1	1
CO2	1	1
CO3	1	1
CO4	1	1
CO5	1	1

UNIT-I: Single Phase & Three Phase Rectifiers

Single phase converters – Half controlled and Fully controlled converters – Evaluation of input power factor and harmonic factor – continuous load current – single phase dual converters– power factor Improvements Techniques– Extinction angle control – symmetrical angle control, PWM– single phase sinusoidal PWM – single phase series converters – overlap analysis – Applications & Problems.

Three phase converters – Half controlled and fully controlled converters – Evaluation of input power factor and harmonic factor – continuous load current – three phase dual.

Practice:

1. Single phase full converter using RL and E loads.
2. Single phase semi converter using RL and E loads.
3. Three phase full converter using RL and E loads.
4. Three phase semi converter using RL and E loads.

AC Voltage Controllers

UNIT-II:

Single phase AC voltage controllers with Resistive, Resistive-inductive and Resistive-inductive-induced e.m.f. loads – ac voltage controllers with PWM Control – Effects of source and load inductances -Synchronous tap changers.

Three phase AC voltage controllers – Analysis of controllers with star and delta Connected Resistive, Resistive-inductive loads – Effects of source and load Inductances – Applications & Problems.

Practice:

1. Single phase AC Voltage controller using RL load.

UNIT-III: Cyclo-Converters

Single phase to single phase cyclo-converters – analysis of midpoint and bridge Configurations – Three phase to three phase cyclo-converters –analysis of Midpoint and bridge configurations – Limitations –Advantages – Applications - Matrix Converter.

Practice:

1. Single phase Cyclo-converter using RL load

UNIT-IV: D.C. to D.C. Converters

Analysis of step - down and step-up dc to dc converters with Resistive and Resistive-inductive loads –Switched mode converters – Analysis of Buck converters - Boost converters – buck and boost converters– Cuk converters – Condition for continuous inductor current and capacitor voltage – comparison of converters.

Practice:

1. BUCK, BOOST and CUCK converters.

UNIT-V: Pulse Width Modulated Inverters

Principle of operation – performance parameters – single phase bridge inverter- evaluation of output voltage and current with resistive, inductive and Capacitive loads– Voltage control of single phase inverters – single PWM – Multiple PWM – sinusoidal PWM – modified PWM – phase displacement Control – Advanced modulation techniques for improved performance – Trapezoidal, staircase, stepped, harmonic injection and delta modulation – Advantages – Applications & Problems.

Three phase inverters- sinusoidal PWM – space vector modulation – Comparison of PWM techniques – harmonic reductions.

Practice:

1. Three phase six stepped inverter
2. Three-phase inverter with PWM controller.
3. Space vector PWM converter

Text Books:

1. Power Electronics by Mohammed H. Rashid, Pearson Education Third Edition. (ISBN:9788120345317)
2. Power Electronics by Ned Mohan, Tore M. Undeland and William P. Robbins, - John Wiley & Sons – Second Edition. (ISBN:9780471226932)

Reference Books:

1. Power converters circuits by Milliman Shepherd and Lizang – Chapter 14 (Matrix converter) PP- 415-444(ISBN: 9780824750541).
2. Power electronics hand book by M.H.Rashid (ISBN: 9780323992169).
3. Control in power electronics by Marian P. Kaźmier kowski, Ramu Krishnan, Frede Blabjerg Edition. (ISBN: 9780124027725)

Web Links:

1. <https://nptel.ac.in/courses/108/108/108108077/>
2. <https://www.electrical4u.com/speed-control-of-three-phase-induction-motor/>
3. <https://www.erode-sengunthar.ac.in/wp-content/uploads/2019/04/Unit4.pdf>

ELECTRICAL DRIVES

Course Code: 242EE002

L	T	P	C
3	0	2	5

Course Outcomes:

At the end of the Course, Student will be able to:

- CO1: Design rectifiers to control DC motor drives.
- CO2: Design DC-DC converters to control DC motor drives
- CO3: Explain principle of operation of scalar control of ac motor and corresponding speed-torque characteristics.
- CO4: Explain the vector control for Induction motor drive.
- CO5: Develop controllers for synchronous motor and variable reluctance motor.

Mapping of Course Outcomes with Program Outcomes:

CO/PO	PO1	PO2	PO3	PO4	PO5	PO6
CO1	2	-	3	1	-	-
CO2	2	-	3	1	-	-
CO3	2	-	3	1	-	-
CO4	2	-	3	1	-	-
CO5	2	-	3	1	-	-

Mapping of Course Outcomes with Program Specific Outcomes:

CO/PSO	PSO1	PSO2
CO1	1	1
CO2	1	1
CO3	1	1
CO4	1	1
CO5	1	1

UNIT-I: Rectifier Controlled DC Motor

Separately excited DC motors and DC series motors with single phase semi converter and single phase full converter-Three-phase controlled converter, control circuit, control modeling of three phase converter – Steady state analysis of three phase converter control DC motor drive – Two quadrant, Three phase converter controlled DC motor drive – DC motor and load, converter **Closed Loop Control of DC Drive:** Current and speed controllers - Current and speed feedback – Design of controllers – Current and speed controllers – Motor equations – filter in the speed feedback loop speed controller – current reference generator – current controller and flow chart for simulation – Harmonics and associated problems – sixth harmonics torque.

UNIT-II: Chopper Controlled DC Motor Drives

Principle of operation of the chopper – Chopper with other power devices – model of the chopper – input to the chopper – steady state analysis of chopper controlled DC motor drives – Closed loop operation: Speed controlled drive system – current control loop – pulse width modulated current controller – hysteresis current controller – modeling of current controller – design of current controller.

Practice:

1. Speed control of separately excited DC Motor Drive with 1 quadrant chopper.
2. Speed control of separately excited DC Motor Drive with 4 quadrant chopper.

UNIT-III: Control of Induction Motor

Introduction to motor drives – Torque production – Equivalent circuit analysis – Speed – Torque Characteristics with variable voltage operation Variable frequency operation constant v/f operation – Variable stator current operation – Induction motor characteristics in constant torque and field weakening regions.

Stator Side Control: Scalar control – Voltage fed inverter control – Open loop volts/Hz control – speed control slip regulation – speed control with torque and flux control – current controlled voltage fed inverter drive

Rotor Side Control of Induction Motor Drives: Slip power recovery drives – Static Kramer Drive – Phasor diagram – Torque expression – speed control of Kramer Drive – Static Scheribus Drive – modes of operation.

Practice:

1. Speed control of 3-phase wound rotor Induction Motor Drive.
2. Speed control of 3-phase doubly fed Induction Motor Drive.
3. Speed control of 5-phase Induction Motor Drive.
4. Speed control of 3-phase Induction Motor Drive using V/F control.

UNIT-IV: Vector Control of Induction Motor Drives

Principles of Vector control – Vector control methods – Direct methods of vector control – Indirect methods of vector control – Adaptive control principles – Self tuning regulator Model referencing control – Direct torque control of AC motors.

Practice:

1. Speed control of 3-phase Induction Motor Drive using Vector Control technique.

UNIT-V: Control of Synchronous Motor Drives

Synchronous motor and its characteristics – Control strategies – Constant torque angle control – Unity power factor control – Constant mutual flux linkage control – closed loop operation.

Additional Practice:

1. Speed control of BLDC Motor Drive.
2. Multilevel inverter based AC Induction Motor Drive control equipment.
3. Speed Measurement and closed loop control using PMDC Motor Drive.
4. Speed measurement and closed loop control of PMDC Motor Drive with thyristor circuit.
5. Matrix Converter

6. Speed measurement and closed loop control of IGBT used single 4 quadrant chopper for PMDC Motor Drive.
7. Isolated Gate Drive circuits for MOSFET / IGBT based circuits

Text Books:

1. Electric Motor Drives: Modeling, Analysis and control – R. Krishnan – Pearson Publications (ISBN: 9780130910141).
2. Modern Power Electronics and AC Drives B K Bose – Pearson Publications 1st edition. (ISBN-13: 9780130167439)

Reference Books:

1. Power Electronics and Control of AC Motors – MD Murthy and FG Turn Bull Pergman Press Edition (ISBN: 9780080405018)
2. Power Electronics and AC Drives – BK Bose – Prentice Hall Eagle wood diff's New Jersey - 1st edition. (ISBN: 9780136868828)
3. Power Electronic circuits Deices and Applications – M H Rashid – PHI. (ISBN: 9788120345317)

Web Links:

1. <https://archive.nptel.ac.in/courses/108/104/108104140/>
2. <https://nptel.ac.in/courses/108104011>
3. https://onlinecourses.nptel.ac.in/noc22_ee94/preview

ELECTRICAL MACHINE MODELING & ANALYSIS

Course Code: 242EE003

L	T	P	C
3	0	0	3

Course Outcomes:

At the end of the Course, Student will be able to:

- CO 1: Analyze the behaviour of DC machines models for different applications.
- CO 2: Evaluate the characteristics of different types of DC machines for designing suitable controllers.
- CO 3: Make use of the reference frame theory of AC machines to model the induction and Synchronous machines.
- CO 4: Evaluate the steady state and transient behaviour of induction machines to propose the suitability of drives for different industrial applications.
- CO 5: Evaluate the steady state and transient behaviour of synchronous machines to propose the suitability of drives for different industrial applications.

Mapping of Course Outcomes with Program Outcomes:

CO/PO	PO1	PO2	PO3	PO4	PO5	PO6
CO1	1	-	3	1	-	-
CO2	1	-	3	1	-	-
CO3	1	-	3	1	-	-
CO4	1	-	3	1	-	-
CO5	1	-	3	1	-	-

Mapping of Course Outcomes with Program Specific Outcomes:

CO/PSO	PSO1	PSO2
CO1	1	1
CO2	1	1
CO3	1	1
CO4	1	1
CO5	1	1

UNIT-I: Basic concepts of Modelling

Basic two-pole machine representation of commutator machines, representations of 3- phase synchronous machine with and without damper bars and 3-phase induction machine, Kron's primitive Machine voltage, current and torque equations.

UNIT-II: DC Machine Modelling

Mathematical model of separately excited D.C motor – Steady state analysis-transient State analysis sudden application of inertia load-transfer function of separately excited D.C motor- Mathematical model of D.C Series motor, Shunt motor-Linearization techniques for small perturbations.

UNIT-III: Modelling of single phase Induction Machines

Linear transformation-Phase transformation - three phase to two phase transformation (abc to $\alpha\beta 0$) and vice-versa, transformation to rotating reference frame, ($\alpha\beta 0$ to $dq0$) and vice versa -Power equivalence- Mathematical modelling of single-phase induction machines.

UNIT-IV: Modelling of three phase Induction Machines

Generalized model in arbitrary reference frame-Derivation of commonly used induction machine models- Synchronously rotating reference frame model, Stator reference frame model-Rotor reference frame model--power equation, electromagnetic torque equation, state space model in induction motor with flux linkages as variables.

UNIT-V: Modelling of Synchronous Machine

Synchronous machine inductances –derivation of voltage equations in the rotor's $dq0$ reference frame electromagnetic torque-current in terms of flux linkages-three phase synchronous motor. State space models with flux linkages as variables.

Text Books:

1. Analysis of Electric Machinery and Drive Systems, 3rd Edition-Wiley-IEEE Press- Paul Krause, Oleg Wasynczuk, Scott D. Sudhoff, Steven Pekarek. (ISBN: 9780471143260)
2. Analysis of Electric Machinery and Drive Systems Krause, Paul C. - Wasynczuk, Oleg - Sudhoff, Scott D. - Pekarek, Steven D. (ISBN: 9781394293865)

Reference Books:

1. Generalized theory of Electrical Machines - P. S. Bimbhra, Khanna Publishers Fifth edition. (ISBN: 9789391505080)
2. Dynamic simulation of Electric machinery using MATLAB / Simulink – Chee MunOng- Prentice Hall. (ISBN: 9780137237852)

Web Links:

1. <https://nptel.ac.in/courses/108106023>
2. <https://innovationspace.ansys.com/product/modelling-and-analysis-of-electric-machines/>

REACTIVE POWER COMPENSATION AND MANAGEMENT

Course Code: 242EE004

L	T	P	C
3	0	0	3

Course Outcomes:

At the end of the Course, Student will be able to:

- CO 1: Distinguish the importance of load compensation in symmetrical loads.
- CO 2: Distinguish the importance of load compensation in unsymmetrical loads.
- CO 3: Observe various compensation methods in transmission lines
- CO 4: Construct model for reactive power coordination
- CO 5: Distinguish demand side reactive power management & user side reactive power management.

Mapping of Course Outcomes with Program Outcomes:

CO/PO	PO1	PO2	PO3	PO4	PO5	PO6
CO1	2	-	3	1	-	-
CO2	2	-	3	1	-	-
CO3	2	-	3	1	-	-
CO4	2	-	3	1	-	-
CO5	2	-	3	1	-	-

Mapping of Course Outcomes with Program Specific Outcomes:

CO/PSO	PSO1	PSO2
CO1	2	1
CO2	2	1
CO3	2	1
CO4	2	1
CO5	2	1

UNIT-I: Load Compensation

Objectives and specifications – reactive power characteristics – inductive and capacitive approximate biasing – Load compensator as a voltage regulator – phase balancing and power factor correction of unsymmetrical loads.

UNIT-II: Steady-State Reactive Power Compensation in Transmission System

Uncompensated line – types of compensation – Passive shunt and series and dynamic shunt Compensation.

Transient State Reactive Power Compensation in Transmission Systems: Characteristic time periods – passive shunt compensation – static compensations - series capacitor compensation using synchronous condensers.

UNIT-III: Reactive Power Coordination

Objective – Mathematical modeling – Operation planning – transmission benefits – Basic concepts of quality of power supply – disturbances- steady –state variations – effects of under voltages – frequency –Harmonics, radio frequency and electromagnetic interferences.

UNIT-IV: Demand Side Management

Load patterns – basic methods load shaping – power tariffs- KVAR based tariffs penalties for voltage flickers and Harmonic voltage levels.

Distribution Side Reactive Power Management: System losses –loss reduction methods – examples – Reactive power planning – objectives – Economics Planning capacitor placement – retrofitting of capacitor banks.

UNIT-V: User Side Reactive Power Management

KVAR requirements for domestic appliances – Purpose of using capacitors – selection of capacitors – deciding factors – types of available capacitor, characteristics and Limitations.

Reactive Power Management In Electric Traction Systems And Arc Furnaces: Typical layout of traction systems – reactive power control requirements – distribution transformers- Electric arc furnaces – basic operations- furnaces transformer –filter requirements – remedial measures –power factor of an arc furnace.

Text Book

1. Reactive power control in Electric systems by T.J.E.Miller, John Wiley and sons. (ISBN: 9780471869337)
2. An Introduction to Reactive Power Control and Voltage Stability in Power Transmission Systems by Chakrabarti , A. Kothari, D.P Mukhopadhyay, A. K. DE, Abhinandan, PHI. (ISBN: 9788120340503)

Reference Books:

1. Reactive Power Compensation: A Practical Guide Wolfgang Hofmann, Jurgen Schlabbach, Wolfgang Just, Wiley publication. (ISBN: 9780470977187)
2. Reactive power control in AC power systems by Frede Blaabjerg, springer. (ISBN: 9783319845715)

Web Links:

1. <https://nptel.ac.in/courses/108108036>
2. <https://nptel.ac.in/courses/108/105/108105180/>
3. <https://cds.cern.ch/record/987552/files/p185.pdf>

ADVANCED POWER ELECTRONIC CONVERTERS

Course Code: 242EE005

L	T	P	C
3	0	1	4

Course Outcomes:

At the end of the Course, Student will be able to:

- CO 1: Explain the various advanced power electronics devices.
- CO 2: Develop and analyze Resonant Pulse Inverters
- CO 3: Develop and analyze various converter topologies
- CO 4: Describe the operation of multi level inverters with switching strategies for high power applications.
- CO 5: Design AC and DC switched mode power supplies

Mapping of Course Outcomes with Program Outcomes:

CO/PO	PO1	PO2	PO3	PO4	PO5	PO6
CO1	2	-	3	1	-	-
CO2	2	-	3	1	-	-
CO3	2	-	3	1	-	-
CO4	2	-	3	1	-	-
CO5	2	-	3	1	-	-

Mapping of Course Outcomes with Program Specific Outcomes:

CO/PSO	PSO1	PSO2
CO1	1	1
CO2	1	1
CO3	1	1
CO4	1	1
CO5	1	1

UNIT-I: Modern Power Semiconductor Devices

MOSFET-Insulated Gate Bipolar Transistor (IGBT) –Silicon-carbide (SiC) Power Devices- MOSFET, IGBT and Schottky barrier diodes and applications.

UNIT-II: Resonant Pulse Inverters

Resonant pulse inverters – series resonant inverters – series resonant inverters with unidirectional switches and bidirectional switches – analysis of half bridge resonant inverter – evaluation of currents and voltages of a simple resonant inverter – analysis of half bridge and full bridge resonant inverter with bidirectional switches – Frequency response of series resonant inverters – for series loaded inverter – for parallel loaded inverter.

Practice:

1. Series resonant converter
2. Parallel resonant converter

UNIT-III: Resonant Converters

Resonant converters – zero current switching resonant converters – L type ZCS resonant converter – M type ZCS resonant converter – zero voltage switching resonant converters – comparison between ZCS and ZVS resonant converters – Two quadrant ZVS resonant converters – resonant dc-link inverters – evaluation of L and C for a zero current switching inverter.

Practice:

1. ZVS converter
2. ZCS converter

UNIT-IV: Multilevel Inverters

Multilevel concept – Classification of multilevel inverters – principle of operation – main features of Diode clamped Multilevel inverter – Flying capacitors multilevel inverter- cascaded multilevel inverter. Multilevel inverter applications – reactive power compensation- comparisons of multilevel converters.

Practice:

1. Single phase diode clamped multilevel inverter.
2. Single phase flying capacitor multilevel inverter
3. Single phase cascaded multilevel inverter

UNIT-V: D.C & A.C Power Supplies

DC power supplies – classification - switched mode dc power supplies – fly back Converter – forward converter – push-pull converter – half bridge converter – Full bridge converter – Resonant dc power supplies – bidirectional power supplies – Applications. AC power supplies – classification – switched mode ac power supplies.

Practice:

1. Push pull converter
2. Fly back converter
3. Forward converter

Text Books:

1. Power Electronics by Mohammed H. Rashid, Pearson Education Third Edition. (ISBN:9788120345317)
2. Advanced Power Electronics by Aleksandar Mratinkovic & Team Of Editors, 3G ELearning (ISBN: 9781680954814)

Reference Books:

1. Power converters circuits by Milliman Shepherd and Lizang – Chapter 14 (Matrix converter) PP- 415-444(ISBN: 9780824750541).
2. Power electronics hand book by M.H.Rashid (ISBN: 9780323992169).
3. Control in power electronics by Marian P. Kmier kowski, R Krishnan, FBlabjerg Edition. (ISBN: 9780124027725)

Web Links:

1. <https://nptel.ac.in/courses/108/108/108108077/>
2. <https://www.electrical4u.com/speed-control-of-three-phase-induction-motor/>
3. <https://www.erode-sengunthar.ac.in/wp-content/uploads/2019/04/Unit4.pdf>

INTELLIGENT CONTROL TECHNIQUES IN ELECTRIC DRIVES

Course Code: 242EE006

L	T	P	C
3	0	2	5

Course Outcomes:

At the end of the Course, Student will be able to:

- CO 1: Explain the concepts of Artificial Neural Networks.
- CO 2: Distinguish between knowledge-based systems and algorithmic based systems.
- CO 3: Explain operation of Fuzzy Controller and Evolutionary Algorithm.
- CO 4: Develop evolutionary algorithm for optimization.
- CO 5: Apply soft computing techniques for industrial problems.

Mapping of Course Outcomes with Program Outcomes:

CO/PO	PO1	PO2	PO3	PO4	PO5	PO6
CO1	2	-	3	2	1	-
CO2	2	-	3	2	1	-
CO3	2	-	3	2	1	-
CO4	2	-	3	2	1	-
CO5	2	-	3	2	1	-

Mapping of Course Outcomes with Program Specific Outcomes:

CO/PSO	PSO1	PSO2
CO1	2	2
CO2	2	2
CO3	2	2
CO4	2	2
CO5	2	2

UNIT-I: Artificial Neural Networks

Models of Neuron Network, Architectures, Knowledge representation. Single-layer ANN, Multi-layer ANN, Radial basis function neural network. Various ANNs and training strategies for different applications, Application of the error back propagation algorithm, Nodes, layers. Back propagation training and learning.

Practice:

1. ANN based speed and torque estimation of DC motor.

UNIT-II: Fuzzy Logic

Fuzzy versus Crisp, Fuzzy sets, Membership function, Basic Fuzzy set operations, Properties of Fuzzy sets, Fuzzy Cartesian Product, Operations on Fuzzy relations, Fuzzy logic, Fuzzy Quantifiers, Fuzzy Inference, Fuzzy Rule based system, Defuzzification methods.

Practice:

1. Steady-state and transient analysis of induction machine system using Fuzzy Logic.
2. Fuzzy based speed, armature current and flux controller of DC motor

UNIT-III: Genetic Algorithms

Encoding –Fitness Function–Reproduction operators, Genetic Modeling –Genetic operators–Cross over, Mutation, Potential applications of Genetic algorithms. Tuning of membership functions using genetic algorithms, Application of genetic algorithms to neural networks, tuning of controllers using genetic algorithms.

Practice:

1. Tuning of PID Controller using Real Coded Genetic Algorithm (RCGA).
2. Speed Control of DC motor using Binary Coded Genetic Algorithm (BCGA).

UNIT-IV: Meta heuristic Optimization Techniques

Particle swarm optimization (PSO), Anatomy of a particle equation based on velocity and positions, PSO topologies, control parameters. Artificial bee colony (ABC) algorithm, Differential Evolution.

Multi Objective Optimization: Multi-Objective optimization Introduction- Concept of Pareto optimality - Non-dominant sorting technique-Pareto fronts-best compromise solution-min-max method-NSGA-II algorithm and applications.

Practice:

1. Solve the benchmark problems using Particle Swarm Optimization (PSO) technique.
2. Tuning of PID Controller using Particle Swarm Optimization (PSO) technique.
3. Speed Control of induction machines using Artificial bee colony (ABC) algorithm.

UNIT-V: Artificial-Intelligence-Based Motor Drives

ANN based speed and torque estimation for a DC motor and slip-ring induction machine. Fuzzy-neural based speed estimator for a DC motor. Design and simulation of fuzzy-neural based induction motor drive. GA & PSO based steady-state and transient analysis of induction machines.

Practice:

1. Simultaneous speed, torque and flux estimation using ANNs for a squirrel-cage induction machine.
2. Simulation of fuzzy-neural based DC motor.

Additional Practice:

1. Study and practice the basic MATLAB programming.
2. Solve the benchmark problems using Differential Evolution (DE) technique.

Text Books:

1. Artificial-Intelligence-based Electrical Machines and Drives, Peter Vas, Oxford University press. (ISBN: 9780198593973)
2. Recent Advances in Swarm Intelligence an Evolutionary Computation, Xin-She Yang, Springer International Publishing, Switzerland, 1st Edition. (ISBN: 9783319356815)

Reference Books:

1. Neural Network & Fuzzy System, Bart Kosko; Prentice Hall. (ISBN: 9780136114352)
2. Fuzzy Set Theory Fuzzy Logic and Their Applications, A. K. Bhargava, S. Chand. (ISBN: 9788121941945)
3. Artificial Intelligence and Intelligent Systems, N P Padhy, Oxford University Press. (ISBN: 9780195671544)

Web Links:

1. <https://nptel.ac.in/courses/108/104/108104157/>
2. <https://nptel.ac.in/courses/108/108/108108148/>
3. <https://nptel.ac.in/courses/112/105/112105235>

SMART GRID TECHNOLOGIES

Course Code: 242EE007

L	T	P	C
3	0	0	3

Course Outcomes:

At the end of the Course, Student will be able to:

CO1: Analyze the smart grids and its policies and developments.

CO2: Develop the basic concepts of smart grid technologies in hybrid electrical vehicles.

CO3: Explain the smart substations, feeder automation, GIS.

CO4: Illustrate micro grids and distributed generation systems.

CO5: Investigate the effect of power quality in smart grid and to understand latest developments in ICT for smart grid.

Mapping of Course Outcomes with Program Outcomes:

CO/PO	PO1	PO2	PO3	PO4	PO5	PO6
CO1	2	-	3	1	-	-
CO2	2	-	3	1	-	-
CO3	2	-	3	1	-	-
CO4	2	-	3	1	-	-
CO5	2	-	3	1	-	-

Mapping of Course Outcomes with Program Specific Outcomes:

CO/PSO	PSO1	PSO2
CO1	2	2
CO2	2	2
CO3	2	2
CO4	2	2
CO5	2	2

UNIT– I: Introduction to Smart Grid

Introduction to Smart Grid, Working definitions of Smart Grid and Associated Concepts, Smart Grid Functions, Traditional Power Grid and Smart Grid, New Technologies for Smart Grid, Advantages, Indian Smart Grid, Key Challenges for Smart Grid.

UNIT– II: Smart Grid Architecture

Components and Architecture of Smart Grid Design – Review of the proposed architectures for Smart Grid. The fundamental components of Smart Grid designs – Transmission Automation – Distribution Automation – Renewable Integration.

UNIT–III: Smart Grid Technologies

Smart Grid Technology Drivers, Smart substations, Substation Automation, Feeder Automation, Transmission systems, EMS, FACTS and HVDC, Wide area monitoring, Protection and control, Distribution systems, DMS, Volt/VAR control, Fault Detection, Isolation and service restoration, Outage management, High-Efficiency Distribution Transformers, Phase Shifting Transformers.

UNIT– IV: Distribution Generation Technologies

Introduction to Renewable Energy Technologies, Storage Technologies, Electric Vehicles and plug in hybrids, Environmental impact and Climate Change – Economic Issues.

UNIT– V: Power Quality Management In Smart Grid

Power Quality in Smart Grid, Power Quality issues of Grid connected Renewable Energy Sources, Power Quality Conditioners for Smart Grid, Web based Power Quality monitoring, Power Quality Audit.

Smart Grid Communications: Local Area Network (LAN), House Area Network (HAN), Wide Area Network (WAN), Broadband over Power line (BPL), IP based Protocols, Wireless Sensor Networks (WSNs) Cyber Security for Smart Grid.

Text Books:

1. Integration of Green and Renewable Energy in Electric Power Systems by Ali Keyhani, Mohammad N. Marwali, Min Dai, Wiley.(ISBN:9780470187760)
2. The Smart Grid: Enabling Energy Efficiency and Demand Response by Clark W. Gellings, CRC Press. .(ISBN:9781439815748)

Reference Books:

1. Smart Grid: Technology and Applications by Janaka Ekanayake, Nick Jenkins, Kithsiri Liyanage, Jianzhong Wu, Akihiko Yokoyama, Wiley Jean Claude. .(ISBN:97804709974094)
2. Smart Grids by Frank J. Longo, Wiley-ISTE.(ISBN:9781848212619)
3. Smart Power: Climate Changes, the Smart Grid, and the Future of Electric Utilities by Peter S. Fox Penner, Island Press; 1 edition. .(ISBN:9781610915892)

Web Links:

1. <https://archive.nptel.ac.in/courses/108/107/108107113/>
2. <https://www.edx.org/learn/smart-grids>

ENERGY STORAGE TECHNOLOGIES

Course Code: 242EE008

L	T	P	C
3	0	0	3

Course Outcomes:

At the end of the Course, Student will be able to:

- CO 1: Explain the role of electrical energy storage technologies in electricity usage
- CO 2: Explain the behavior and features of electrical energy storage systems.
- CO 3: Analyze the applications of energy storage system.
- CO 4: Explain the hierarchy, demand for energy storage and valuation techniques
- CO 5: Explain about energy storage forecasting methods.

Mapping of Course Outcomes with Program Outcomes:

CO/PO	PO1	PO2	PO3	PO4	PO5	PO6
CO1	2	-	3	1	-	-
CO2	2	-	3	1	-	-
CO3	2	-	3	1	-	-
CO4	2	-	3	1	-	-
CO5	2	-	3	1	-	-

Mapping of Course Outcomes with Program Specific Outcomes:

CO/PSO	PSO1	PSO2
CO1	1	1
CO2	1	1
CO3	1	1
CO4	1	1
CO5	1	1

UNIT-I: The Roles of Electrical Energy Storage Technologies in Electricity Use

Characteristics of electricity, Electricity and the roles of EES, High generation cost during peak-demand periods, Need for continuous and flexible supply, Long distance between generation and consumption, Congestion in power grids, Transmission by cable, Emerging needs for EES, More renewable energy, less fossil fuel, Smart Grid uses, The roles of electrical energy storage technologies, The roles from the viewpoint of a utility, The roles from the viewpoint of consumers, The roles from the viewpoint of generators of renewable energy.

UNIT-II: Types and Features of Energy Storage Systems

Classification of EES systems, Mechanical storage systems, Pumped hydro storage (PHS), Compressed air energy storage (CAES), Flywheel energy storage (FES), Electrochemical storage systems, Secondary batteries, Lead-Acid Batteries, Lithium-Ion Batteries, Flow batteries, Other Batteries in Development, Chemical energy storage, Hydrogen (H₂), Synthetic natural gas (SNG), Electrical storage systems, Double-layer capacitors (DLC), Superconducting magnetic energy storage (SMES), Thermal storage systems, Technical comparison of EES technologies.

UNIT-III: Applications of EES

Present status of applications, Utility use (conventional power generation, grid operation & service), Consumer use (uninterruptable power supply for large consumers), EES installed capacity worldwide, New trends in applications, Renewable energy generation, Smart Grid, Smart Micro grid, Smart House, Electric vehicles.

UNIT-IV: Management and Control Hierarchy of EES

Internal configuration of battery storage systems, External connection of EES systems, Aggregating EES systems and distributed generation (Virtual Power Plant), “Battery SCADA” – aggregation of many dispersed batteries.

Demand for Energy Storage: Growth in Variable Energy Resources, Relationship between balancing services and variable energy resources, Energy Storage Alternatives, Variable Generator Control, Demand Management, Market Mechanisms, and Longer Term Outlook.

Valuation Techniques: Overview, Energy Storage Operational Optimization, Market Price Method, Power System Dispatch Model Method, Ancillary Service Representation, Energy Storage Representation, Survey of Valuation Results..

UNIT-V: Forecast of EES Market Potential by 2030

EES market potential for overall applications, EES market estimation by Sandia National Laboratory (SNL), EES market estimation by the Boston Consulting Group (BCG), EES market estimation for Li-ion batteries by the Panasonic Group, EES market potential estimation for broad introduction of renewable energies, EES market potential estimation for Germany by Fraunhofer, Storage of large amounts of energy in gas grids, EES market potential estimation for Europe by Siemens, EES market potential estimation by the IEA, Vehicle to grid concept, EES market potential in the future.

Text Books:

1. Power System Energy Storage Technologies, 1st Edition by Paul Breeze, Academic Press. (ISBN-13: 9780128129029)
2. Energy Storage: Systems and Components, by Alfred Rufer, CRC Press. (ISBN: 9781138082625)

Reference Books:

1. Energy Storage Fundamentals, Materials and Applications, by Huggins and Robert, Springer. (ISBN: 9783319331089)
2. Principles of Energy Storage Systems by P. Jayarama Reddy, BS Publications. (ISBN: 9789395038089)

Web Links:

1. <https://www.pdfdrive.com/non-conventional-energy-systems-ntel-d17376903.html>
2. <https://www.pdfdrive.com/renewable-energy-sources-and-their-applications-e33423592.html>
3. https://onlinecourses.nptel.ac.in/noc18_ge09/preview.

RENEWABLE ENERGY TECHNOLOGIES

Course Code: 242EE009

L	T	P	C
3	0	0	3

Course Outcomes:

At the end of the Course, Student will be able to:

- CO 1: Describe the environmental aspects of Renewable Energy Resources.
- CO 2: Describe the use of Solar Energy and the various components used in the energy production.
- CO 3: Explain the conversion principles of Wind and Biomass Energy Resources.
- CO 4: Acquire the basic knowledge of Ocean Thermal Energy
- CO 5: Acquire the basic knowledge of energy conversion and Hydrogen Energy.

Mapping of Course Outcomes with Program Outcomes:

CO/PO	PO1	PO2	PO3	PO4	PO5	PO6
CO1	2	-	3	1	-	-
CO2	2	-	3	1	-	-
CO3	2	-	3	1	-	-
CO4	2	-	3	1	-	-
CO5	2	-	3	1	-	-

Mapping of Course Outcomes with Program Specific Outcomes:

CO/PSO	PSO1	PSO2
CO1	1	1
CO2	1	1
CO3	1	1
CO4	1	1
CO5	1	1

UNIT-I: Introduction

Principles of renewable energy; energy and sustainable development, renewable energy availability in India and worldwide, Atmospheric pollution, effects of hydro-electric projects, disposal of nuclear waste, greenhouse gas emission from various energy sources and its effects, need for renewable energy sources, brief descriptions on solar energy, wind energy, ocean energy, biomass energy, geothermal energy.

UNIT-II: Solar Energy

Solar radiation and its measurement, Angle of sun rays on solar collector, optimal angle for fixed collector, sun tracking, Technologies for solar thermal power generation and Storage; Photovoltaic power generation system; Maximum Power Point Tracking techniques, Applications.

UNIT-III: Wind Energy

Estimation of wind energy potential and site selection; Types of wind mills, their basic characteristics and applications, aerodynamic operation of wind turbine, extraction of wind turbine power, wind turbine power curve, Recent Technologies of wind energy conversion system (WECS), wind farms.

Biomass: Estimation of Biomass resources, Biomass Technologies for thermal and biological conversion; Biomass based Electricity Generation and application of bio-fuels.

UNIT-IV: Ocean Thermal Energy Conversion

Principle of working, OTEC power stations in the world, problems associated with OTEC. Ocean Thermal Energy Conversion methods.

Geothermal Energy & Fuel cells: Types of fields and power plants, Fuel cells working, Classification of fuel cells.

UNIT-V: Hybrid energy systems

Need for hybrid systems, types, configuration and coordination, electrical interface- PV-Diesel, Wind-diesel, wind-PV, wind-PV- fuel cell.

Text Books:

1. Non-Conventional energy resources, Khan B.H, Tata Mc-Graw hill.(ISBN: 9789352601882)
2. Non-conventional Energy Sources, G.D.Rai, Khanna Publications. (ISBN: 9788174090737)

Reference Books:

1. Renewable energy resources, Twidell, J.W. and Weir, A., BSP Books Pvt.Ltd, UK.(ISBN: 9780415633581)
2. Renewable Energy Technologies, R.Ramesh, Udaykumar, Narosa Publishing House. (ISBN: 9788184875812)

Web Links:

1. <https://www.pdfdrive.com/non-conventional-energy-systems-ntel-d17376903.html>
2. <https://www.pdfdrive.com/renewable-energy-sources-and-their-applications-e33423592.html>
3. https://onlinecourses.nptel.ac.in/noc18_ge09/preview.

HVDC TRANSMISSION AND FLEXIBLE AC TRANSMISSION SYSTEMS

Course Code: 242EE010

L	T	P	C
3	0	0	3

Course Outcomes:

At the end of the Course, Student will be able to:

- CO 1: Compare HVDC and HVAC transmission systems.
- CO 2: Analyze converter configurations used in HVDC and evaluate the performance metrics.
- CO 3: Recognize controllers for controlling the power flow through a dc link and compute filter Parameters.
- CO 4: Apply impedance, phase angle and voltage control for real and reactive power flow in AC transmission systems with FACTS controller.
- CO 5: Analyze and select a suitable FACTS controller for a given power flow condition.

Mapping of Course Outcomes with Program Outcomes:

CO/PO	PO1	PO2	PO3	PO4	PO5	PO6
CO1	2	-	3	1	-	-
CO2	2	-	3	1	-	-
CO3	2	-	3	1	-	-
CO4	2	-	3	1	-	-
CO5	2	-	3	1	-	-

Mapping of Course Outcomes with Program Specific Outcomes:

CO/PSO	PSO1	PSO2
CO1	1	-
CO2	1	-
CO3	2	1
CO4	2	1
CO5	2	1

UNIT-I: HVDC Transmission

DC Power Transmission: Power system interconnections, Evolution of AC and DC transmission systems, Comparison of HVDC and HVAC Transmission systems, Types of DC links, relative merits, Components of a HVDC system, Modern trends in DC Transmission systems.

UNIT-II: Analysis of HVDC Converters

Pulse number, choice of converter configurations, Analysis of Graetz circuit with and without overlap, voltage waveforms, Analysis of two and three valve conduction mode, Converter Bridge characteristics, Inverter mode of operation, voltage waveforms

UNIT-III: HVDC Control

Principles of DC link control, Converter Control characteristics, Control hierarchy Constant current Control, CEA Control, firing angle control of valves, starting and stopping of a dc link, Power control.

Harmonics and Filters: effects of Harmonics, sources of harmonic generation, Types of filters – Design examples.

UNIT-IV: Power Flow Analysis in AC/DC Systems

Modelling of DC links, solutions of AC-DC Power flow, Power flow in AC systems, and relative importance of controllable parameters.

Flexible AC Transmission Systems (FACTS): FACTS concepts and general system conditions, Basic types of FACTS controllers, shunt and series controllers, Current source and Voltage source converters.

UNIT-V: Static Shunt Compensators

Objectives of shunt compensation, Methods of controllable VAR generation, Static Var Compensator, its characteristics, TCR, TSC, STATCOM, basic operating principle, control approaches and characteristics.

Static Series Compensators: Objectives of series compensator, variable impedance type of series compensators, TCSC, TSSC-operating principles and control schemes, SSSC, Power Angle characteristics, Control range and VAR rating, Capability to provide reactive power compensation, external control.

Text Books:

1. Understanding FACTS –Concepts and Technology of Flexible AC Transmission Systems
Narain G.Hingorani, Laszlo Gyugyi, Wiley-IEEE Press.(ISBN: 9788186308790)
2. HVDC Power Transmission Systems –Technology and System Interactions, K.R.Padiyar, New Age International Publishers.(ISBN: 9780470217061)

Reference Books:

1. FACTS Controllers in Power Transmission and Distribution, Padiyar.K.R New Age Int. Publishers.(ISBN: 9789389802047)
2. High Voltage Direct Current Transmission, Jos Arrillaga, The Institution of electrical Engineers.(ISBN: 9780852969410)

Web Links:

1. <https://nptel.ac.in/courses/108/107/108107157/>
2. <https://nptel.ac.in/courses/108/107/108107114/>
3. <https://nptel.ac.in/courses/108108099/>

EMBEDED SYSTEMS FOR POWER ELECTRONICS

Course Code: 242EE011

L	T	P	C
3	0	0	3

Course Outcomes:

Course Outcomes: At the end of the Course, Student will be able to:

- CO 1: Design the interfacing circuits for input and output to PIC micro controllers
- CO 2: Design the interfacing circuits for input and output to DSP processors
- CO 3: Develop ALP for DSP processors
- CO 4: Apply ADC in DSP and compare the QEP
- CO 5: Design PWM controller for power electronic circuits using

Mapping of Course Outcomes with Program Outcomes:

CO/PO	PO1	PO2	PO3	PO4	PO5	PO6
CO1	2	-	3	1	-	-
CO2	2	-	3	1	-	-
CO3	2	-	3	1	-	-
CO4	2	-	3	1	-	-
CO5	2	-	3	1	-	-

Mapping of Course Outcomes with Program Specific Outcomes:

CO/PSO	PSO1	PSO2
CO1	1	-
CO2	1	-
CO3	1	-
CO4	1	-
CO5	1	-

UNIT-I: PIC Microcontrollers

Overview and Features, PIC 16C6X/7X, File Selection Register [Indirect Data Memory Address Pointer], PIC Reset Actions, PIC Oscillator Connections, PIC Memory Organizations, PIC 16C6X/7X Instructions, Addressing Modes, I/O Ports, Interrupts in PIC 16C61/71, PIC 16C61/71 Timers, PIC 16C71 Analog-to-Digital Converter (ADC).

UNIT-II: Digital signal processor (DSP)

C2xx DSP: Components, core and code generation, Mapping external devices to the C2xx core, peripherals and Peripheral Interface, System configuration registers, Memory, Types of Physical Memory, memory Addressing Modes, Assembly Programming using C2xx DSP, Instruction Set, Software Tools.

UNIT-III: I/O & Control Registers

Pin Multiplexing (MUX) and General Purpose I/O Overview, Multiplexing and General Purpose I/O Control Registers .Introduction to Interrupts, Interrupt Hierarchy, Interrupt Control Registers, Initializing and Servicing Interrupts in Software.

UNIT-IV: Analog to Digital Converters (ADC) & Event Manager

ADC Overview, Operation of the ADC in the DSP, Overview of the Event manager (EV), Event Manager Interrupts, General Purpose (GP) Timers, Compare UNITS, Capture UNITS and Quadrature Enclosed Pulse (QEP) Circuitry, General Event Manager Information.

UNIT-V: Field Programmable Gate Arrays (FPGA)

Complex Programmable Logic Device (CPLD) Vs FPGA – Types of FPGA, Xilinx C3000 series, Configurable logic Blocks (CLB), Input/Output Block (IOB) – Programmable Interconnect Point (PIP) – Xilinx 4000 series – HDL programming – overview of Spartan 3E and Virtex II pro FPGA boards- case study.

Text Books:

1. Microcontrollers-Theory and Applications - Ajay V Deshmukh, McGraw Hills.(ISBN: 9780070585959)
2. DSP- Based Electromechanical Motion Control (Power Electronics and Applications Series) -Hamid.A.Toliyat and Steven G.Campbell, CRC Press New York.(ISBN: 9780849319181)

Reference Books:

1. The 8051 Microcontroller-Kennith J ayala, Thomson publishers.(ISBN: 9788131502006)
2. Microprocessor and Microcontrollers by A. Nagoor Kani, CBS Publishers & Distributors Pvt Ltd, India (ISBN: 9789354660924)

Web Links:

1. <https://archive.nptel.ac.in/courses/108/105/108105102/>
2. https://josephcollege.ac.in/lms/Uploads/pdf/material/Event_Management.pdf

PROGRAMMABLE LOGIC CONTROLLERS and APPLICATIONS

Course Code: 242EE012

L	T	P	C
3	0	0	3

Course Outcomes:

At the end of the Course, Student will be able to:

- CO 1 : Explain the PLCs and their I/O modules.
- CO 2 : Develop control algorithms to PLC using ladder logic.
- CO 3 : Describe effective utilization of PLC registers in different applications
- CO 4 : Illustrate control functions of two axis and three axis robots With PLC
- CO 5 : Design PID controller with PLC

Mapping of Course Outcomes with Program Outcomes::

CO/PO	PO1	PO2	PO3	PO4	PO5	PO6
CO1	1	-	3	1	-	-
CO2	1	-	3	1	-	-
CO3	1	-	3	1	-	-
CO4	1	-	3	1	-	-
CO5	1	-	3	1	-	-

Mapping of Course Outcomes with Program Specific Outcomes

CO/PSO	PSO1	PSO2
CO1	1	1
CO2	1	1
CO3	1	1
CO4	1	1
CO5	1	1

UNIT-I: PLC Basics

PLC system, I/O modules and interfacing, CPU processor, programming equipment, programming formats, construction of PLC ladder diagrams, devices connected to I/O modules.

UNIT-II: Analog PLC operation

Analog modules and systems, Analog signal processing, multi bit data processing, analog output application examples, PID principles, position indicator with PID control, PID modules, PID tuning, PID functions.

UNIT-III: Data handling functions

SKIP, Master control Relay, Jump, Move, FIFO, FAL, ONS, CLR and Sweep functions and their applications. Bit Pattern and changing a bit shift register, sequence functions and applications, controlling of two axis and three axis Robots with PLC, Matrix functions.

UNIT-IV: PLC Registers

Characteristics of Registers, module addressing, holding registers, input registers, output registers. PLC Functions: Timer functions and Industrial applications, counters, counter function industrial applications, Arithmetic functions, Number comparison functions, number conversion functions.

UNIT-V: PLC Programming

Input instructions, outputs, operational procedures, programming examples using contacts and coils. Drill press operation, Digital logic gates, programming in the Boolean algebra system, conversion examples. Ladder diagrams for process control: Ladder diagrams and sequence listings, ladder diagram construction and flow chart for spray process system.

Text Books:

1. Programmable Logic Controllers Principle and Applications by John W. Webb and Ronald A. Reiss, Fifth Edition, PHI.(ISBN: 9780024249807)
2. Programmable Logic Controllers-Programming Method and Applications by JR. Hackworth and F.D Hackworth Jr. – Pearson.(ISBN: 9798351114668)

Reference Books:

1. Introduction to Programmable Logic Controllers-Gary Dunning-Cengage Learning.(ISBN: 9781401884260)
2. Programmable Logic Controllers -W.Bolton-Elsevier publisher.(ISBN: 9780028026619)

Web links:

1. https://en.wikipedia.org/wiki/Programmable_logic_controller
2. <https://www.engineersgarage.com/articles/plc-programmable-logic-controller>
3. <https://www.deltaelectronicsindia.com/products/IABU-programmable-Logic-Controller>

DIGITAL SIGNAL PROCESSING CONTROLLED DRIVES

Course Code: 242EE013

L	T	P	C
3	0	0	3

Course Outcomes:

Course Outcomes: At the end of the Course, Student will be able to:

CO 1: Develop Assembly Language Programs for the Digital Signal Processors.

CO 2: Develop the Clarke's and Park's transformation using Digital Signal Processors.

CO 3: Design and implementation of PWM Techniques for 3-Ph VSI using Digital Signal Processors.

CO 4: Develop the drive control system for BLDC Motor using Digital Signal Processors.

CO 5: Develop the drive control system for PMSM Motor using Digital Signal Processor.

Mapping of Course Outcomes with Program Outcomes:

CO/PO	PO1	PO2	PO3	PO4	PO5	PO6
CO1	1	-	3	1	-	-
CO2	1	-	3	1	-	-
CO3	1	-	2	1	-	-
CO4	1	-	3	1	-	-
CO5	1	-	3	1	-	-

Mapping of Course Outcomes with Program Specific Outcomes:

CO/PSO	PSO1	PSO2
CO1	1	-
CO2	1	-
CO3	1	-
CO4	1	-
CO5	1	-

UNIT-I: Overview of TMS320LF2407 DSP controller:

Review of Instruction Set, Interrupts, normalization and number formatting.

UNIT-II: Clarke's and Park's transformations:

Review of Clarke's and Park's transformations, Implementation of Clarke's and Park's transformation using TMS320LF2407 DSP.

UNIT-III: Implementation of PWM Techniques

Implementation of PWM Techniques for 3-Ph VSI Implementation of Sine-triangle and SVPWM with TMS320LF2407 DSP using the concept of imaginary switching time.

UNIT-IV:Control of BLDC Motor

Principle of operation with Drive control system, implementation of control system using TMS320LF2407 DSP.

UNIT-V: Control of PMSM

Principle of operation with drive control system, implementation of vector control using TMS320LF2407DSP.

Text Books

1. DSP Based Electromechanical Motion Control by Hamid A. Toliyat:, 1st Edition, CRC Press. (ISBN: 9780367394967)
2. Power Electronics: Converters, Applications by Ned Mohan, T.M. Undeland and William P. Robbins, 3rd Edition, John Wiley & Sons.(ISBN: 978-8126510900)

Reference Books:

1. Digital Signal Processing in Power Electronics Control Circuits (Power Systems) by Sozański, Springer (ISBN: 9781447173311).
2. Electric Motor Drives-Modelling, Analysis and Control- By R. Krishnan, Prentice Hall of India. (ISBN: 9789332549715)

Web Links:

1. <https://archive.nptel.ac.in/courses/108/101/108101174/>
2. <https://www.digimat.in/nptel/courses/video/108105055/L01.html>

POWER CONVERTER TECHNOLOGIES

Course Code: 242EE014

L	T	P	C
3	0	0	3

Course Outcomes:

Course Outcomes: At the end of the Course, Student will be able to:

- CO 1: Analyze power electronic application requirements.
- CO 2: Identify suitable power converter from the available configurations.
- CO 3: Develop improved power converters for any stringent application requirements.
- CO 4: Illustrate the existing control techniques to suit the application.
- CO 5: Design of Bi-directional converters for charge/discharge applications.

Mapping of Course Outcomes with Program Outcomes:

CO/PO	PO1	PO2	PO3	PO4	PO5	PO6
CO1	2	-	3	1	-	-
CO2	2	-	3	1	-	-
CO3	2	-	3	1	-	-
CO4	2	-	3	1	-	-
CO5	2	-	3	1	-	-

Mapping of Course Outcomes with Program Specific Outcomes:

CO/PSO	PSO1	PSO2
CO1	2	2
CO2	2	2
CO3	2	2
CO4	2	2
CO5	2	2

UNIT-I: Inverters for Induction Appliances

Types of Induction Heating and welding, Inverters for- induction heating, induction cooking, induction hardening, induction melting, and induction welding.

UNIT-II: Power Converters applications

Electronic ballast, LED power drivers for indoor and outdoor applications. PFC based grid fed LED drivers, PV / battery fed LED drivers. PV fed power supplies for pumping/refrigeration applications.

UNIT-III: High Voltage Power Supplies

Power supplies for X-ray applications, power supplies for radar applications, power supplies for space applications.

UNIT-IV: Low voltage high current power supplies

Power converters for modern microprocessor, computer loads, Audio systems and Electric Vehicles.

UNIT-V: Bi-directional DC-DC (BDC) converters

Electric traction, automotive Electronics and charge/discharge applications, Line Conditioners and Solar Charge Controllers.

Text Books:

1. Uninterruptible Power Supplies and Active Filters by Ali Emadi, A. Nasiri, and S. B. Bekiarov: CRC Press.(ISBN: 9781420037869)
2. Modern Electric, Hybrid Electric and Fuel Cell Vehicles by M. Ehsani, Y. Gao, E. G. Sebastien and A. Emadi, CRC Press(ISBN: 9781498761772)

Reference Books:

1. Hand book of Induction Heating, Valery Rudnev, Don Loveless, Raymond L. Cook, CRC Press.(ISBN: 9781138748743)
2. Power Supplies for LED Driving, Steve Winder, Newnes.(ISBN: 9780081009253)

Web Links:

1. <http://digimat.in/nptel/courses/video/108104013/L05.html>
2. <https://nptel.ac.in/courses/113104074>

SWITCHED MODE POWER CONVERSION

Course Code: 242EE015

L	T	P	C
3	0	0	3

Course Outcomes:

At the end of the Course, Student will be able to:

- CO 1: Analyze the operation of DC-DC converters
- CO 2: Calculate minimum inductance, capacitance in single switch DC-DC converters
- CO 3: Analyze the operation and control of resonant converters
- CO 4: Derive the transfer functions for buck, boost, and fly-back topologies.
- CO 5: Design DC-DC converters and evaluate the stability of the system.

Mapping of Course Outcomes with Program Outcomes:

CO/PO	PO1	PO2	PO3	PO4	PO5	PO6
CO1	2	-	3	1	-	-
CO2	2	-	3	1	-	-
CO3	2	-	3	1	-	-
CO4	2	-	3	1	-	-
CO5	2	-	3	1	-	-

Mapping of Course Outcomes with Program Specific Outcomes:

CO/PSO	PSO1	PSO2
CO1	2	1
CO2	2	1
CO3	2	1
CO4	2	1
CO5	2	1

UNIT-I: DC/DC Converters

Isolated DC/DC converter topologies: forward, and fly-back converters, half and full bridge topologies, modeling of switching converters. Voltage mode and current mode control of converters, peak and average current mode control, its advantages and limitations, voltage and current fed converters.

UNIT-II: Current Mode and Current Fed Topologies

Voltage mode and current mode control of converters, peak and average current mode control, its advantages and limitations, voltage and current fed converters.

UNIT-III: Resonant Converters

Need for resonant converters, types of resonant converters, methods of control, phase- modulation technique with ZVS in full-bridge topology, series resonant converter and resonant transition converter.

UNIT-IV: Converter Transfer Functions

Application of state-space averaging to switching converters, derivation of converter transfer functions for buck, boost, and fly-back topologies.

UNIT-V: Power Converter Design

Design of filter inductor, capacitor, and power transformer. Ratings for switching devices, current transformer for current sensing, design of drive circuits for switching devices, considerations for PCB layout.

Text Books:

1. Power Electronics: Converters, Applications, and Design by Ned Mohan Tore M. Undeland, 3rd Edition, John Wiley & Sons.(ISBN: 9780471226932)
2. Switching Power Supply Design by Abraham I. Pressman, McGraw Hill International.(ISBN: 9780071482721)

Reference Books:

1. Modern Power Electronics by P. C. Sen, S.Chand. (ISBN: 9788121924252)
2. Power electronics handbook by Muhammad H. Rashid, Butterworth Heinemann. (ISBN: 9780323992169).
3. Power Electronics: Essentials and applications by L. Umanand, Wiley publications. (ISBN: 9788126519453)

Web Links:

1. <https://nptel.ac.in/courses/108108036>
2. <https://nptel.ac.in/courses/108/105/108105180/>
3. <https://cds.cern.ch/record/987552/files/p185.pdf>

CONTROL AND INTEGRATION OF RENEWABLE ENERGY SYSTEMS

Course Code: 242EE016

L	T	P	C
3	0	0	3

Course Outcomes:

At the end of the Course, Student will be able to:

CO 1: Illustrate the different conventional & non-conventional dynamic energy conversion technologies..

CO 2: Analyze the principles of dynamic Energy conversion technologies.

CO 3: Analyze the principles of static energy conversion technologies.

CO 4: Explain the control of frequency and voltage using linear and non linear controllers

CO 5: Develop converters to comply with grid standards to obtain grid integration.

Mapping of Course Outcomes with Program Outcomes:

CO/PO	PO1	PO2	PO3	PO4	PO5	PO6
CO1	1	-	3	2	-	-
CO2	1	-	3	2	-	-
CO3	1	-	3	2	-	-
CO4	1	-	3	2	-	-
CO5	1	-	3	2	-	-

Mapping of Course Outcomes with Program Specific Outcomes:

CO/PSO	PSO1	PSO2
CO1	2	1
CO2	2	1
CO3	2	1
CO4	2	1
CO5	2	1

UNIT-I: Energy sources to Grid

Electric grid, Utility ideal features, Supply guarantee, power quality, Stability and cost; Importance & Effects of Renewable Energy penetration into the grid, Boundaries of the actual grid configuration, Consumption models and patterns.

UNIT-II: Dynamic Energy Conversion Technologies

Types of conventional and nonconventional dynamic generation technologies, principle of operation and analysis of reciprocating engines, gas and micro turbines, hydro and wind-based generation technologies.

UNIT-III: Static Energy Conversion Technologies

Types of conventional and nonconventional static generation technologies; Principle of operation and analysis of fuel cell, photovoltaic systems and wind generation technologies; MPPT techniques and its classifications, principle of operation and partial shading effects; Storage Technologies - batteries, fly wheels, super capacitors and ultra-capacitors.

UNIT-IV: Control Issues and Challenges

Linear and nonlinear controllers, predictive controllers and adaptive controllers, Load frequency and Voltage Control, PLL, Modulation Techniques, Control of Diesel, PV, wind and fuel cell based generators, Dimensioning of filters, Fault-ride through Capabilities.

UNIT-V: Integration of Energy Conversion Technologies

Importance, sizing, Optimized integrated systems, Interfacing requirements, Distributed versus Centralized Control, Grid connected Photovoltaic systems –classifications, operation, merits & demerits; Islanding Operations, stability and protection issues, load sharing, operation & control of hybrid energy systems, Solar Photovoltaic applications.

Text Books:

1. Renewable and Efficient Electric Power Systems, G. Masters, IEEE-John Wiley and Sons Ltd. Publishers.(ISBN: 9781119847106)
2. Microgrids and Active Distribution Networks, S. Chowdhury, S. P. Chowdhury, P.Crossley, IET Power Electronics Series.(ISBN: 9781849190145)

Reference Books:

1. Solar Photovoltaics - Fundamentals, technologies & Applications Solar Photovoltaic, Chetan Singh Solanki, PHI Publishers.(ISBN: 9788120351110)
2. Control of Power Inverters in Renewable Energy and Smart Grid Integration, Quing Chang Zhong, IEEE-John Wiley and Sons Ltd. Publishers.(ISBN: 9780470667095)
3. Power Conversion and Control of Wind Energy Systems, Bin Wu, Yongqiang Lang, Navid Zargari, IEEE- John Wiley and Sons Ltd. Publishers.(ISBN: 9780470593653)

Web links:

1. <https://nptel.ac.in/courses/108/102/108102145/>
2. <https://nptel.ac.in/courses/103/103/103103206/>

MODERN CONTROL THEORY

Course Code: 242EE017

L	T	P	C
3	0	0	3

Course Outcomes:

At the end of the Course, Student will be able to:

CO 1: Explain the state variable approach for higher order systems.

CO 2: Examine the concepts of controllability and observability.

CO 3: Analyze the various non-linearities through describing functions and phase plane analysis.

CO 4: Illustrate the different stability issues of continuous time invariant systems.

CO 5: Discuss the various linear time invariant systems using time state equations.

Mapping of Course Outcomes with Program Outcomes:

	PO1	PO2	PO3	PO4	PO5	PO6
CO1	1	-	3	1	-	-
CO2	1	-	3	1	-	-
CO3	1	-	3	1	-	-
CO4	1	-	3	1	-	-
CO5	1	-	3	1	-	-

Mapping of Course Outcomes with Program Specific Outcomes:

	PSO1	PSO2
CO1	1	-
CO2	1	-
CO3	1	-
CO4	1	-
CO5	1	-

UNIT-I: State Variable Analysis

The concept of state - State Equations for Dynamic systems - State diagram – Linear Continuous time model for physical systems - Existence and Uniqueness of Solutions to Continuous - Time State Equations - Solutions - Linear Time Invariant Continuous- Time State Equations

UNIT-II: State Variable Techniques

General concept of Controllability - General concept of Observability Controllability and Observability tests for Continuous & Time Invariant systems and Jordan Canonical form - Controllability and Observability Canonical forms of State model - State feedback controller design through pole assignment.

UNIT-III: Non Linear Systems – I

Introduction to Non Linear Systems, Types of Non – Linearities, Saturation, Dead, Zone, Backlash, Jump Phenomenon etc; Singular Points, Introduction to Linearization of nonlinear systems, properties of Non Linear Systems, Describing function, describing function analysis of nonlinear systems- Stability analysis of Non - Linear systems through describing functions.

UNIT-IV: Non Linear Systems – II

Introduction to phase - plane analysis, Method of Isoclines for Constructing Trajectories, singular points, phase - plane analysis of nonlinear control systems.

UNIT-V: Stability Analysis

Lyapunov's stability and Lyapunov's instability theorems - Stability Analysis of the Linear Continuous time invariant systems by Lyapunov second method - Generation of Lyapunov functions - Variable gradient method - Krasooviski's method.

Text Books:

1. Modern Control System Theory , M. Gopal ,New Age International.(ISBN: 9788195175598)
2. Modern Control Engineering by Ogata. K , Prentice Hall.(ISBN: 9788120340107)

Reference Books:

1. Nonlinear systems, Hassan K. Klalil, Prentice Hall.(ISBN: 9780130673893)
2. Modern control systems, Richard C. Dorf and Robert H. Bishop, Pearson Edu.(ISBN: 9781292422374)

Web Links:

1. https://en.wikipedia.org/wiki/control_theory
2. <https://www.ece.ufl.edu/content/modern-control-theory>
3. <http://www.springer.com/in/book/9783540239512>

POWER QUALITY AND CUSTOM POWER DEVICES

Course Code: 242EE018

L	T	P	C
3	0	0	3

Course Outcomes:

At the end of the Course, Student will be able to:

CO 1: Identify the issues related to power quality in power systems.

CO 2: Address the problems of transient and long duration voltage variations in power systems.

CO 3: Analyze the effects of harmonics and study different mitigation techniques.

CO 4: Identify the importance of custom power devices and their applications.

CO 5: Acquire knowledge on different compensation techniques to minimize power quality disturbances.

Mapping of Course Outcomes with Program Outcomes:

CO/PO	PO1	PO2	PO3	PO4	PO5	PO6
CO1	2	-	3	1	-	-
CO2	2	-	3	1	-	-
CO3	2	-	3	1	-	-
CO4	2	-	3	1	-	-
CO5	2	-	3	1	-	-

Mapping of Course Outcomes with Program Specific Outcomes

CO/PSO	PSO1	PSO2
CO1	2	1
CO2	2	1
CO3	2	1
CO4	2	1
CO5	2	1

UNIT-I: Introduction to power quality

General Classes of Power Quality Problems, Voltage Unbalance, Waveform Distortion, Voltage fluctuation, Power Frequency Variations, Power Quality Terms, Voltage Sags, swells, flicker and Interruptions, Sources of voltage and current interruptions, Nonlinear loads.

UNIT-II: Transient and Long Duration Voltage Variations

Source of Transient over Voltages, Principles of over Voltage Protection, Devices for Over Voltage Protection, Principles of Regulating the Voltage, Device for Voltage Regulation, Utility Voltage Regulator Application, Capacitor for Voltage Regulation, Regulating Utility Voltage with Distributed generation.

UNIT-III: Harmonic Distortion and solutions

Power System Quantities under Non-sinusoidal Conditions, Harmonic Indices, Sources of harmonics, Locating Sources of Harmonics, System Response Characteristics, Effects of Harmonic Distortion, Inter harmonics, Harmonic Distortion Evaluation, Controlling devices, Filter Design.

UNIT-IV: Custom Power Devices-I

Voltage source inverters, reactive power and harmonic compensation devices, compensation of voltage and current interruptions, static series and shunt compensators, compensation in distribution systems, interaction with distribution equipment, installation considerations.

UNIT-V: Custom Power Devices-II

Static and hybrid Source Transfer Switches, Solid state current limiter, Solid state breaker, P-Q theory, Control of P and Q, Operation and control of Dynamic Voltage Restorer (DVR), Interline Power Flow Controller (IPFC) and Unified Power Quality Conditioner (UPQC).

Text Books:

1. Electrical Power Systems Quality by Dugan RC, McGranaghan MF, SantosoS, and Beaty H W Second Edition, McGraw-Hill.(ISBN: 9781259005572)
2. Custom Power Devices for Efficient Distributed Energy Systems by Al-durra; Ahmed (edt); Arya; Sabha Raj (edt); Giri; Ashutosh K. (edt), Elsevier. (ISBN: 9780443214912)

Reference Books:

1. Power Quality, C.Shankaran, CRC Press. (ISBN: 9780367396466)
2. Custom Power Devices-An Introduction, Arindam Ghoshand Gerard Ledwich, Springer. (ISBN: 9781402071805)

Web Links:

1. <http://nptel.ac.in/courses/108106025/>
2. <http://nptel.ac.in/courses/108104013/>

DIGITAL CONTROL SYSTEMS

Course Code: 242EE019

L	T	P	C
3	0	0	3

Course Outcomes:

At the end of the Course, Student will be able to:

- CO 1: Explain the concepts of digital control systems and assemble various components associated with it.
- CO 2: Analyze the theory of z-transformations and application for the mathematical analysis of digital control systems
- CO 3: Apply the discrete-time systems in state-space model and evaluation of state transition matrix.
- CO 4: Analyze the stability of the system using different tests and study the conventional method of analyzing digital control systems in the w-plane.
- CO 5: Design of state feedback controller through pole placement.

Mapping of Course Outcomes with Program Outcomes:

CO/PO	PO1	PO2	PO3	PO4	PO5	PO6
CO1	1	-	3	1	-	-
CO2	1	-	3	1	-	-
CO3	1	-	3	1	-	-
CO4	1	-	3	1	-	-
CO5	1	-	3	1	-	-

Mapping of Course Outcomes with Program Specific Outcomes:

CO/PSO	PSO1	PSO2
CO1	1	-
CO2	1	-
CO3	1	-
CO4	1	-
CO5	1	-

UNIT-I: Introduction to Signal Processing

Introduction to analog and digital control systems – Advantages of digital systems –Continuous and Discrete Time Signals – Sample and hold devices – Sampling theorem and data reconstruction – Frequency domain characteristics of zero order hold.

UNIT-II: Z-Transformations

Z-Transforms – Theorems – inverse Z-transforms – Formulation of difference equations and solving – Block diagram representation – Pulse transfer functions and finding open loop and closed loop responses.

UNIT-III: State Space Analysis and the Concepts of Controllability and Observability

State space representation of discrete time systems – Solving Discrete Time state space equations – State transition matrix and its properties – Concepts of controllability and observability

UNIT-IV: Stability Analysis

Mapping between the S-Plane and the Z-Plane – Primary strips and Complementary strips – Stability criterion – Modified Routh's stability criterion and Jury's stability -Design using frequency response in the w-plane for lag and lead compensators – Root locus technique in the z-plane

UNIT-V: State Feedback Controllers and State Observers

Design of state feedback controller through pole placement – Necessary and sufficient conditions – Ackerman's formula – Design of state observers

Text Books:

1. Discrete-Time Control systems – K. Ogata - Pearson Education/PHI.(ISBN:9789332549661)
2. Digital Control and State Variable Methods by M.Gopal - TMH. (ISBN: 9780071333276)

Reference Books:

1. Digital Control Systems - Kuo - Oxford University Press.(ISBN: 9780195120646)
2. Digital Control Systems: Design, Identification and Implementation by Ioan Dore Landau and Gianluca Zito, Springer London Ltd. (ISBN: 9781846280559)

Web Links:

1. <https://archive.nptel.ac.in/courses/108/103/108103008/>
2. <https://ocw.mit.edu/courses/2-171-analysis-and-design-of-digital-control-systems-fall-2006/>

ADVANCED DIGITAL SIGNAL PROCESSING

Course Code: 242EE020	L	T	P	C
	3	0	0	3

Course Outcomes:

At the end of the Course, Student will be able to:

- CO1: Determine and analyze the frequency response and the z-transform of discrete-time systems.
- CO2: Apply wavelets for signal processing
- CO3: Analyze the various adaptive filter algorithms.
- CO4: Analyze the various Recursion algorithms.
- CO5: Interpret the statistical properties of the conventional spectral estimators.

Mapping of Course Outcomes with Program Outcomes:

CO/PO	PO1	PO2	PO3	PO4	PO5	PO6
CO1	1	-	3	1	-	-
CO2	1	-	3	1	-	-
CO3	1	-	3	1	-	-
CO4	1	-	3	1	-	-
CO5	1	-	3	1	-	-

Mapping of Course Outcomes with Program Specific Outcomes:

CO\PSO	PSO1	PSO2
CO1	1	-
CO2	1	-
CO3	1	-
CO4	1	-
CO5	1	-

UNIT-I: Sampling

Review of sampling theory, sampling rate conversion by integer and rational factors, efficient realization and applications of sampling rate conversion.

Unit-II: Wavelet Theory

Classes of wavelets, Construction of continuous wavelets, Inverse continuous wavelet transform, Redundancy of CWT, Zoom property, Filtering, Discrete Wavelet Transform (DWT), Non-linear approximation in the Wavelet domain, Construction and Computation of the DWT, Parameterization of discrete wavelets, Bi-orthogonal wavelet bases.

UNIT-III: Adaptive Filters

Adaptive filters, FIR adaptive LMS algorithm, Convergence of adaptive algorithms, Fast algorithms, Applications, Noise canceller, echo canceller and equalizer.

UNIT-IV: Recursive

Recursive least squares algorithms. Matrix inversion lemma, Convergence analysis of the RLS algorithm, Adaptive beam forming, Kalman filtering.

UNIT-V: Spectrum

Spectrum estimation, Estimation of autocorrelation, Periodogram method, Non parametric methods, parametric methods.

Text Books:

1. Advanced Digital Signal Processing, J.G.Proakis, M. Salehi, McGraw –Hill.(ISBN: 9780023968419)
2. Adaptive Filter Theory (3/e), S.Haykin, Prentice- Hall.(ISBN: 9788131708699)

Reference Books:

1. Statistical and Adaptive Signal Processing, D.G.Manolakis, V. K. Ingle, and S. M. Kogon, McGraw-Hill. (ISBN: 9781630812034)
2. Digital Signal Processing, John G. Proakis, and Dimitris G, Pearson Education India Pvt. Ltd., 2021.(ISBN: 9780133737622)

Web Links:

1. <https://ekeeda.com/degree-courses/electrical-engineering/advanced-digital-signal-processing>
2. <https://archive.nptel.ac.in/courses/117/101/117101001/>
3. <https://nptel.ac.in/courses/108101174>

ELECTRIC VEHICLES AND DRIVES

Course Code: 242EE021

L	T	P	C
3	0	0	3

Course Outcomes:

At the end of the Course, Student will be able to:

- CO 1: Illustrate the History of Hybrid Electric vehicles
- CO 2: Classify the various electric drive train topologies
- CO 3: Analyze the Energy Storage Requirements in Hybrid and Electric Vehicles
- CO 4: Illustrate the Charging Infrastructure
- CO 5: Evaluate Energy Management Strategies used in hybrid and electric vehicle

Mapping of Course Outcomes with Program Outcomes:

CO/PO	PO1	PO2	PO3	PO4	PO5	PO6
CO1	1	-	3	2	-	-
CO2	1	-	3	2	-	-
CO3	1	-	3	2	-	-
CO4	1	-	3	2	-	-
CO5	1	-	3	2	-	-

Mapping of Course Outcomes with Program Specific Outcomes:

CO/PSO	PSO1	PSO2
CO1	2	1
CO2	2	1
CO3	2	1
CO4	2	1
CO5	2	1

UNIT-I: History of electric vehicles

Origin of electric vehicles, social and environmental importance of electric vehicles, impact of modern drive-trains on energy supplies-Challenges and Key Technologies of EVs – Challenges for EV Industry in India

UNIT-II: Electric Drive Trains

Basic concept of electric traction - introduction to various electric drivetrain topologies - Power flow control in electric drive-train topologies - various drive-train topologies - Configuration and control of DC Motor drives, Configuration and control of Induction Motor drives, configuration and control of Permanent Magnet Motor drives, Configuration and control of Switch Reluctance Motor drives, drive system efficiency.

UNIT-III: Energy Storage

Introduction to Energy Storage Requirements in Hybrid and Electric Vehicles -Battery based energy storage and its analysis - Fuel Cell based energy storage and its analysis - Super Capacitor based energy storage- Flywheel based energy storage and its analysis

UNIT-IV: Charging Infrastructure

Domestic charging infrastructure - public charging infrastructure - Normal charging station - Occasional charging station - Fast charging station - Battery swapping station - Types of charging: constant voltage - Constant current- Pulse charging – Inductive -Conductive charging.

UNIT-V: Energy Management Strategies

Introduction to Energy Management Strategies used in hybrid and electric vehicle, Classification of different Energy Management strategies - Comparison of different Energy Management Strategies – Implementation issues of energy strategies - Effect of charging infrastructure on grid protection and control.

Textbooks:

1. Emerging Technologies for Electric and Hybrid Vehicles, Christopher H. T. Lee, Springer, 2024.(ISBN: 9783038971900)
2. The Electric Cars, Plug-Ins and Hybrids Handbook, Augustin Stucker, 2022.(ISBN: 9781520693941)

Reference Books:

1. Electric and Hybrid Vehicles: Design Fundamentals,Iqbal Husain, CRC Press, 2021.(ISBN: 9780367693930)
2. Electric Vehicles: Modern Technologies and Trends, Nil Patel, Springer, 2021.(ISBN: 9789811592508)
3. Electric Vehicle Engineering, Per Enge, Nick Enge, Stephen Zoepf, McGraw Hill, 2021. (ISBN: 9781265900526)

Web Links:

1. <https://nptel.ac.in/courses/108102121>
2. <https://nptel.ac.in/courses/108103009>
3. <https://nptel.ac.in/courses/108106170>
4. <https://www.nrel.gov/research/transportation-hybrid-electric.html>

MODELING AND SIMULATION OF POWER ELECTRONIC SYSTEMS

Course Code: 242EE022

L	T	P	C
3	0	0	3

Course Outcomes:

At the end of the Course, Student will be able to:

- CO 1 : Explain the basic knowledge and terminology of the simulation software.
- CO 2 : Choose the required numerical solver to be used for analysis.
- CO 3 : Solve the convergence problems occurring during simulation.
- CO 4 : Analyze the concept of transient switching in circuit analysis.
- CO 5 : Analyze state space averaging technique of switching converters.

Mapping of Course Outcomes with Program Outcomes:

CO/PO	PO1	PO2	PO3	PO4	PO5	PO6
CO1	1	-	3	1	-	-
CO2	1	-	3	1	-	-
CO3	1	-	3	1	-	-
CO4	1	-	3	1	-	-
CO5	1	-	3	1	-	-

Mapping of Course Outcomes with Program Specific Outcomes

CO/PSO	PSO1	PSO2
CO1	1	1
CO2	1	1
CO3	1	1
CO4	1	1
CO5	1	1

UNIT-I: Modeling, simulation of switching converters

State space approach, averaging method, State Space Averaging Technique, Modeling and linearization of converter transfer functions, Hybrid Modeling for DC- DC converter.

UNIT-II: Simulation of power electronic converters

Nodal Analysis Modified Nodal Analysis (MNA) and Spare Tableau (ST) Approaches, Nonlinear Circuits, The Newton-Raphson Method, Computation Time, Convergence Issues, Nonlinear Circuit Equations.

UNIT-III: Transient Simulation

Methods of Transient Simulation – Forward Euler(FE),Backward Euler (BE) and Trapezoidal Rule with Zoh(TRZ), Transient Analysis in Circuit Simulation, Undamped Oscillations, Ringing, Global Error in Switching Circuits, Round-off Error, Assessment of Accuracy, Singular Matrix Problem, Trapezoidal integration, M & N method for simulating buck converter.

UNIT-IV: Switching functions

Properties and Application of the switching function technique, Voltage-Current relations in switched circuits - Single Switch, Parallel Switch, Pulse Width Modulation-Unipolar, PWM Signal of a composite function, bipolar square wave modulation, Modeling using switching function-buck converter, Rectifier, 3-phase VSI inverter, matrix converter, m-phase rectifier. PWM rectifier topologies, modeling of power electronic converters - PWM rectifier in different frames- abc, alpha-beta and d-q.

UNIT-V: Computer Simulation of PE Converters

Challenges in computer simulation - Simulation process - mechanics of simulation, Solution techniques for time domain analysis - Equation solvers, circuit-oriented simulators.

Textbook:

1. Simulation of Power Electronic Converters, by M. B. Patil, V.Ramnarayanan, Ranganathan V.T. Narosa Publishers. (ISBN: 9788173199899)
2. Fundamentals of Power Electronics by R. W. Erickson, D. Maksimovic, Kluwer Academic Publishers. (ISBN: 9783030438791)

Reference book:

1. Power Electronics: Converters, Design and control by NedMohan, Undeland and Robbins, John Wiley (ISBN: 9788126510900)
2. Principles of Power Electronics by J. Kassakian, M. F. Schlecht, and G. C. Verghese, Addison-Wesley Publishing Company.(ISBN: 9780201096897)

Web links:

1. <https://link.springer.com/book/10.1007/978-3-030-54124-8>
2. <https://ieeexplore.ieee.org/iel5/5/20157/931486/931486.plain.html>

ADVANCED CONTROL SYSTEMS

Course Code: 242EE023

L	T	P	C
3	0	0	3

Course Outcomes:

At the end of the Course, Student will be able to:

- CO 1: Apply state space representation to formulate different state models.
- CO 2: Design control system using the pole placement technique.
- CO 3: Analyze the nonlinear system using the describing function technique and phase plane analysis.
- CO 4: Analyze the stability analysis using Lypunov’s method.
- CO 5: Explain the Minimization of functional using calculus of variation studied.

Mapping of Course Outcomes with Program Outcomes:

CO/PO	PO1	PO2	PO3	PO4	PO5	PO6
CO1	1	-	3	1	-	-
CO2	1	-	3	1	-	-
CO3	1	-	3	1	-	-
CO4	1	-	3	1	-	-
CO5	1	-	3	1	-	-

Mapping of Course Outcomes with Program Specific Outcomes:

CO/PSO	PSO1	PSO2
CO1	1	1
CO2	1	1
CO3	1	1
CO4	1	1
CO5	1	1

UNIT-I: State Space Analysis

State Space Representation – Canonical forms – Controllable canonical form – Observable canonical form - Jordan Canonical Form - Solution of state equation – State transition matrix

UNIT-II: Controllability - Observability and Design of Pole Placement

Tests for controllability and observability for continuous time systems – Time varying case – Time invariant case– Principle of duality - Design of state feedback control through pole placement.

UNIT-III: Nonlinear Systems

Introduction to nonlinear systems - Types of nonlinearities. Introduction to phase plane analysis - Singular points; Describing function - basic concepts - Describing functions of non-linearity's.

UNIT-IV: Stability analysis by Lyapunov Method

Stability in the sense of Lyapunov – Lyapunov's stability and Lyapunov's instability theorems – Direct method of Lyapunov for the linear and nonlinear continuous time autonomous systems.

UNIT-V: Calculus of Variations

Minimization of functional of single function – Constrained minimization – Minimum principle – Control variable inequality constraints – Control and state variable inequality constraints – Euler lagrangine equation

Text Books:

1. Modern Control Engineering – by K. Ogata - Prentice Hall of India.(ISBN: 9788120340107)
2. Automatic Control Systems by B.C. Kuo - Prentice Hall Publication.(ISBN: 9781259643835)

Reference Books:

1. Modern Control System Theory – by M. Gopal - New Age International Publishers.(ISBN: 9788195175598)
2. Control Systems Engineering by I.J. Nagarath and M.Gopal - New Age International (P) Ltd (ISBN: 9788195175581)
3. Digital Control and State Variable Methods – by M. Gopal - Tata McGraw–Hill Companies. (ISBN: 9780071333276)

Web Links:

1. http://www.nptelvideos.in/2012/11/advanced-control-system-design_27.html
2. <https://nptel.ac.in/courses/108103007/>

BASIC CONCRETE TECHNOLOGY

Course Code: 242CE030

L T P C
3 0 0 3

Course Outcomes:

At the end of the Course, Student will be able to:

- CO 1: Understand the chemical composition, hydration, and physical properties of Portland cement.
- CO 2: Evaluate the effects of mineral and chemical admixtures on concrete performance.
- CO 3: Classify and assess aggregates based on mechanical properties, grading, and thermal behavior.
- CO 4: Analyze workability and setting characteristics of fresh concrete, including relevant testing methods.
- CO 5: Design and proportion concrete mixes using BIS and ACI methods, ensuring quality control.

Mapping of course Outcomes with Program Outcomes:

CO/PO	PO1	PO2	PO3	PO4	PO5	PO6
CO1	2	3	1	-	-	-
CO2	2	1	3	-	-	-
CO3	2	1	3	-	-	-
CO4	2	1	3	-	-	-
CO5	2	2	3	-	-	-

Mapping of course outcomes with program Specific Outcomes:

CO/PSO	PSO1	PSO2
CO1	-	-
CO2	-	-
CO3	-	-
CO4	-	-
CO5	-	-

UNIT – I

Cement: Portland cement – chemical composition – Hydration, Setting of cement – Structure of hydrate cement – Test on physical properties – Different grades of cement.
Admixtures: Types of admixtures – mineral and chemical admixtures.

UNIT - II

Aggregates: Classification of aggregate – Particle shape & texture –, strength & other mechanical properties of aggregate – Specific gravity, Bulk density, porosity, adsorption & moisture content of aggregate – Bulking of sand – Deleterious substance in aggregate – Soundness of aggregate – Alkali aggregate reaction – Thermal properties – Sieve analysis – Fineness modulus – Grading curves – Grading of fine & coarse Aggregates – Gap graded aggregate – Maximum aggregate size.

UNIT – III

Fresh Concrete: Workability – Factors affecting workability – Measurement of workability by different tests – Setting times of concrete – Effect of time and temperature on workability – Segregation & bleeding – Mixing and vibration of concrete – Steps in manufacture of concrete – Quality of mixing water.

UNIT - IV

Hardened Concrete : Water / Cement ratio – Abram’s Law – Gelspaoe ratio – Nature of strength of concrete – Maturity concept – Strength in tension & compression – Factors affecting strength – Relation between compressive & tensile strength - Curing. Testing Of Hardened Concrete: Compression tests – Tension tests– Flexure tests – Splitting tests – Pull-out test, Non-destructive testing methods – codal provisions for NDT. Elasticity, Creep & Shrinkage – Modulus of elasticity – Dynamic modulus of elasticity – Poisson’s ratio – Creep of concrete – Factors influencing creep.

UNIT – V

Mix Design: Factors in the choice of mix proportions – Durability of concrete – Quality Control of concrete – Statistical methods – Acceptance criteria – Proportioning of concrete mixes by IS codes mix design. Special Concretes: Introduction to light weight concrete – Cellular concrete

Text Books:

1. Properties of Concrete by A. M. Neville Pearson 5th edition Education Ltd. (ISBN: 9780273755807)
2. Concrete Technology by M. S. Shetty. – S. Chand & Co. (ISBN: 9788121900034)
3. Concrete Technology by Job Thomas -Cengage learning India Pvt Ltd.(ISBN: 9788131521099)

References:

1. Concrete Technology by M.L. Gambhir. – Tata Mc. Graw Hill Publishers, New Delhi. (ISBN: 9780070141100)
2. Concrete: Microstructure, Properties and Materials – P. K. Mehta and J. M. Monteiro, McGraw Hill Publishers. (ISBN: 9780071797870)

Web Links:

1. www.Nptel.Ac.In/Courses/105102012/
2. www.archive.nptel.ac.in/noc/courses/noc15/SEM1/noc15-ce01
3. <https://archive.nptel.ac.in/courses/105/102/105102012/>

REPAIR AND REHABILITATION OF STRUCTURES

CourseCode:242CE031

L T P C
3 0 0 3

Course Outcomes:

At the end of the Course, Student will be able to

- CO 1: Identify the causes of deterioration of concrete structures.
- CO 2: Illustrate the various materials for repair and rehabilitation techniques.
- CO 3: Construct the various strengthening and stabilization techniques.
- CO 4: Determine various repair techniques of damaged structures.
- CO 5: Evaluate the usage of different types of concretes and durability aspects.
- CO 6: Classify the usage of high performance concretes for repairingworks.

Mapping of Course Outcomes with Program Outcomes:

CO/PO	PO1	PO2	PO3	PO4	PO5	PO6
CO1	3	2	2	2	2	-
CO2	3	2	2	2	2	-
CO3	3	2	2	2	2	-
CO4	3	2	2	2	2	-
CO5	2	2	1	2	1	-

Mapping of Course Outcomes with Program Specific Outcomes:

CO/PSO	PSO1	PSO2
CO1	-	-
CO2	-	-
CO3	-	-
CO4	-	-
CO5	-	-

UNIT-I

Materials for Repair and Rehabilitation:

Admixtures- types of admixtures- purposes of using admixtures- chemical composition- Natural admixtures- Fibers- wraps- Glass and Carbon fiber wraps- Steel Plates-Non destructive evaluation: Importance- Concrete behavior under corrosion, disintegrated mechanisms- moisture effects and thermal effects – Visual investigation- Acoustical emission methods-Corrosion activity measurement-chloridecontent– Depth of carbonation- Impact echo methods- Ultrasound pulse velocity methods- Pull out tests.

UNIT-II

Strengthening and Stabilization:

Techniques- design considerations-Beam shear capacity strengthening- Shear Transfer strengthening-stress reduction techniques- Column strengthening-flexural strengthening- Connection stabilization and strengthening, Crack stabilization.

UNIT-III

Bonded Installation Techniques:

Externally bonded FRP- Wet layup sheet, bolted plate, near surface mounted FRP, fundamental debonding mechanisms-intermediate crack debonding- CDC debonding- plate end debonding- strengthening of floor of structures.

UNIT-IV

Fibre Reinforced Concrete:

Properties of constituent materials- Mix proportions, mixing and casting methods-Mechanical properties of fiber reinforced concrete- applications of fibre reinforced concretes-Light weight concrete- properties of light weightconcrete-Nofinesconcrete-designoflightweightconcrete-Flyashconcrete- Introduction- classification of flyash- properties and reaction mechanism of flyash- Properties of flyash concrete in fresh stateand hardened state- Durability of flyashconcretes.

UNIT-V

High Performance Concrete:

Introduction- Development of high performance concretes-Materials of high performance concretes-Properties of high performance concretes - Self Consolidating concrete-properties- qualifications.

Text Books:

1. Concrete repair and maintenance illustrated-Peter Emmons, published by Brandon W. Emmons.(ISBN: 9780876291916)
2. Experimental Techniques and Instrumentation, Dr.M.Sreenivasa Reddy, Dr.S.Govindarajan and Dr.S.Pachaiappan, Charulatha Publications, 2022.

Reference Books:

1. Rehabilitation of Concrete Structures, Dr. B. Vidivelli, Standard Publishers Distributors. (ISBN: 978-8180140276)
2. Concrete technology, M S Shetty, S. Chand Publications.(ISBN: 9788121900034)
3. Concrete technology, Neville & Brooks, pearson education ltd.(ISBN: 9788131708384)

Web Links:

1. <http://nptel.ac.in/courses/112101095/38>
2. <http://www.nptel.ac.in/courses/105105041/module%206.pdf>
3. https://www.youtube.com/watch?v=N4KrZ_DcZrE

NEURAL NETWORKS AND FUZZY LOGIC

Course Code: 242EE028

L	T	P	C
3	0	0	3

Course Outcomes:

At the end of the Course, Student will be able to:

- CO 1: Explain artificial neuron models.
- CO 2: Explain various learning methods of ANN.
- CO 3: Apply different algorithms of ANN.
- CO 4: Distinguish between Classical and Fuzzy Sets.
- CO 5: Apply application of fuzzy logic control to real time systems.

Mapping of Course Outcomes with Program Outcomes:

CO/PO	PO1	PO2	PO3	PO4	PO5	PO6
CO1	3	-	1	1	-	-
CO2	3	-	1	1	-	-
CO3	3	-	1	1	-	-
CO4	3	-	1	1	-	-
CO5	3	-	1	1	-	-

Mapping of Course Outcomes with Program Specific Outcomes:

CO/PSO	PSO1	PSO2
CO1	-	-
CO2	-	-
CO3	-	-
CO4	-	-
CO5	-	-

UNIT-I: Introduction to Neural Networks

Introduction, Humans and Computers, Organization of the Brain, Biological Neuron, Biological and Artificial Neuron Models, Hodgkin-Huxley Neuron Model, Integrate-and Fire Neuron Model, Spiking Neuron Model, Characteristics of ANN, McCulloch-Pitts Model, Applications of ANN.

UNIT-II: Essentials of Artificial Neural Networks

Artificial Neuron Model, Operations of Artificial Neuron, Types of Neuron Activation Function, ANN Architectures, Classification Taxonomy of ANN, Connectivity, Neural Dynamics (Activation and Synaptic), Learning Strategy (Supervised, Unsupervised, Reinforcement), Learning Rules, Types of Application.

UNIT-III: Multilayer feed forward Neural Networks

Credit Assignment Problem, Generalized Delta Rule, Derivation of Back propagation (BP) Training, Summary of Backpropagation Algorithm, Kolmogorov Theorem, Learning Difficulties and Improvements, Radial Basis Function (RBF) Neural Network – Kohonen Self Organising feature Map (KSOM).

UNIT-IV: Classical & Fuzzy Sets

Introduction to classical sets - properties, Operations and relations; Fuzzy sets, Membership, Uncertainty, Operations, properties, fuzzy relations, cardinalities, membership functions.

UNIT-V: Fuzzy Logic Modules

Fuzzification, Membership value assignment, development of rule base and decision making system, Defuzzification to crisp sets, Defuzzification methods.

Text Books:

1. Neural Networks, Fuzzy logic, Genetic algorithms: synthesis and applications by Rajasekharan and Rai – PHI Publication. (ISBN: 9788120353343)
2. Introduction to Neural Networks using MATLAB 6.0 - S.N.Sivanandam, S.Sumathi, S.N.Deepa, TMH. (ISBN: 9780070591127)

Reference Books:

1. Neural Networks, James A Freeman and Davis Skapura, Pearson Education. (ISBN: 9780201513769)
2. Fuzzy sets University and information, J.Klin and T.A.Folger, Prentice Hall. (ISBN: 9789353065782)
3. Introduction to artificial neural systems, J.M.Zurada, Jaico Publication house.(ISBN: 9780314933911)

Web Links:

1. <http://nptel.ac.in/courses/108104049/16>
2. www.archive.nptel.ac.in/courses/127/105/127105006/
3. www.geeksforgeeks.org/fuzzy-logic-introduction/

HYBRID ELECTRIC VEHICLES

Course Code: 242EE029

L	T	P	C
3	0	0	3

Course Outcomes:

At the end of the Course, Student will be able to:

- CO 1: Analyze the architectures of HEVs with various components.
- CO 2: Illustrate the concept of Electric Vehicle and Hybrid Electric Vehicles.
- CO 3: Explain the Plan concept of Plug-in Electrical Vehicles.
- CO 4: Analyze the power electronics converters for HEVs.
- CO 5: Apply various energy storage technologies in Hybrid Vehicles.

Mapping of Course Outcomes with Program Outcomes:

CO/PO	PO1	PO2	PO3	PO4	PO5	PO6
CO1	1	-	3	2	-	-
CO2	1	-	3	2	-	-
CO3	1	-	3	2	-	-
CO4	1	-	3	2	-	-
CO5	1	-	3	2	-	-

Mapping of Course Outcomes with Program Specific Outcomes:

CO/PSO	PSO1	PSO2
CO1	-	-
CO2	-	-
CO3	-	-
CO4	-	-
CO5	-	-

UNIT-I: Introduction

Introduction to Electric Vehicles: History of electric vehicles, social and environmental importance of electric vehicles, impact of modern drive-trains on energy supplies-Challenges and Key Technologies of EVs – Challenges for EV Industry in India

UNIT-II: Hybridization of Automobile

Fundamentals of vehicle, components of conventional vehicle and propulsion load, Drive cycles and drive terrain, Concept of electric vehicle and hybrid electric vehicle, Plug-in hybrid vehicle, constituents of PHEV, comparison of HEV and PHEV; Fuel Cell vehicles and its constituents.

UNIT-III: Plug-in Hybrid Electric Vehicle

PHEVs and EREVs, PHEV Architectures, equivalent electric range of blended PHEVs, Fuel economy and power management of PHEVs, end-of-life battery for electric power grid support, vehicle to grid technology, battery charging.

UNIT-IV: Power Electronics in HEVs

Rectifiers and Buck converter used in HEVs, isolated and non-isolated bidirectional DC-DC converter, regenerative braking, voltage source inverter, current source inverter, PWM rectifier in HEVs, EV and PHEV battery chargers.

UNIT-V: Battery and Storage Systems:

Energy Storage Parameters; Lead–Acid Batteries; Ultra capacitors; Flywheels - Superconducting Magnetic Storage System; Pumped Hydroelectric Energy Storage; Compressed Air Energy Storage - Storage Heat; Energy Storage as an Economic Resource.

Text Books:

1. Advanced Electric Drive Vehicles, Ali Emadi, CRC Press.(ISBN: 9781138072855)
2. Electric and Hybrid Vehicles: Design Fundamentals, Iqbal Hussein, CRC Press. (ISBN: 9780367693930)

Reference Books:

1. Introduction to Hybrid Vehicle System Modeling and Control, Wei Liu, Wiley.(ISBN: 9788126556205)
2. Electric and Hybrid Vehicles Technologies, Modelling and Control: A Mechatronic Approach”, Amir Khajepour, Saber Fallahand Avesta Goodarzi, John Wiley & Sons Ltd. (ISBN: 9781118341513)

Web Links:

- 1 <https://archive.nptel.ac.in/courses/108/103/108103009/>
2. https://ndl.iitkgp.ac.in/he_document/nptel/nptel/IN_N_1_E_E_12391_I_t_H_a_E_V_1402_4_D_o_H_E_v_14030_14031

GREEN ENGINEERING SYSTEMS

Course Code: 242ME029

L	T	P	C
3	0	0	3

Course Outcomes:

At the end of the Course, Student will be able to:

- CO1:** Distinguish the various solar energy collection methods and measuring instruments.
- CO2:** Explain the different methods of solar energy storage and their applications.
- CO3:** Illustrate the various types of wind mills and performance characteristics.
- CO4:** Explain the principle of Biomass production, Geothermal energy sources and Ocean thermal energy conversion
- CO5:** Illustrate the various types of electrical systems and mechanical systems.
- CO6:** Compare the various energy efficient process.

Mapping of Course Outcomes with Program Outcomes:

CO/PO	PO 1	PO 2	PO 3	PO 4	PO 5	PO 6
CO1	2	1	1	1	-	-
CO2	2	2	1	1	-	-
CO3	2	2	2	1	-	-
CO4	2	1	-	1	-	-
CO5	2	1	-	1	-	-
CO6	2	1	-	1	-	-

Mapping of Course Outcomes with Program Specific Outcomes:

CO/PSO	PSO1	PSO2
CO1	-	3
CO2	-	3
CO3	-	3
CO4	-	3
CO5	-	3

UNIT – I

Introduction: Solar Radiation: Role and potential of new and renewable sources, the solar energy option, Environmental impact of solar power, structure of the sun, the solar constant, sun-earth relationships, coordinate systems of the sun, extraterrestrial and terrestrial solar radiation, solar radiation on titled surface, instruments for measuring solar radiation and sun shine, solar radiation data, numerical problems. Photo voltaic energy conversion – types of PV cells, I-V characteristics

Solar Energy Collection: Flat plate and concentrating collectors, classification of concentrating collectors, orientation and thermal analysis, advanced collectors.

UNIT – II

Solar Energy Storage and Applications: Different methods, sensible, latent heat and stratified storage, solar ponds, solar applications- solar heating/cooling technique, solar distillation and drying, solar cookers, central power tower concept and solar chimney.

Wind Energy: Sources and potentials, horizontal and vertical axis windmills, performance characteristics, betz criteria, types of winds, wind data measurement.

UNIT – III

Bio-Mass: Principles of bio-conversion, anaerobic/aerobic digestion, types of bio-gas digesters, gas yield, combustion characteristics of bio-gas, utilization for cooking, bio fuels, I.C. engine operation and economic aspects.

Geothermal Energy: Resources, types of wells, methods of harnessing the energy, potential in India.

Ocean Energy: OTEC, Principles of utilization, setting of OTEC plants, thermodynamic cycles. Tidal and wave energy: Potential and conversion techniques, mini-hydel power plants, and their economics.

UNIT – IV

Electrical Systems: Energy efficient motors, energy efficient lighting and control, selection of luminaire, variable voltage variable frequency drives (adjustable speed drives), controls for HVAC (heating, ventilation and air conditioning), demand site management.

Mechanical Systems: Fuel cells- principle, thermodynamic aspects, selection of fuels & working of various types of fuel cells, Environmentally friendly and Energy efficient compressors and pumps.

UNIT – V

Energy Efficient Processes: Environmental impact of the current manufacturing practices and systems, benefits of green manufacturing systems, selection of recyclable and environment friendly materials in manufacturing, design and implementation of efficient and sustainable green production systems with examples like environmentally friendly machining, vegetable based cutting fluids, alternate casting and joining techniques, zero waste manufacturing.

Green Buildings: Definition, features and benefits. Sustainable site selection and planning of building for maximum comfort. Environmentally friendly building materials like bamboo, timber, rammed earth, hollow blocks, lime & lime pozzolana cement, agro materials and industrial waste.

Text Books:

- 1 Solar Energy – Principles of Thermal Collection and Storage/Sukhatme S.P. and J.K. Nayak/ TMH.
- 2 Non-Conventional Energy Resources/ Khan B.H/ Tata McGraw Hill, New Delhi,

Reference Books:

- 1 Renewable Energy Technologies /Ramesh & Kumar /Narosa.
- 2 Renewable Energy Resources-2 Edition/ J. Twidell and T. Weir/ BSP Books Pvt. Ltd.

Web Links:

- 1 https://onlinecourses.nptel.ac.in/noc17_me33
- 2 <https://nptel.ac.in/courses/105107176/20>

I.C.ENGINES

Course Code: 242ME030

L	T	P	C
3	0	0	3

Course Outcomes:

At the end of the Course, Student will be able to:

- CO1: Summarize the finite element methods
- CO2: Analyse one-dimensional problems in trusses and beams
- CO3: Solve structural problems using CST and axis - symmetric formulation
- CO4: Apply finite elements to higher order, Iso-parametric elements, and one-dimensional heat transfer analysis.
- CO5: Apply finite element methods to dynamic analysis.

Mapping of Course Outcomes with Program Outcomes:

CO/PO	PO 1	PO 2	PO 3	PO 4	PO 5	PO 6
CO1	2	1	1	1	-	-
CO2	2	2	1	1	-	-
CO3	2	2	2	1	-	-
CO4	2	1	-	1	-	-
CO5	2	1	-	1	-	-

Mapping of Course Outcomes with Program Specific Outcomes:

CO/PSO	PSO1	PSO2
CO1	-	-
CO2	-	-
CO3	-	-
CO4	-	-
CO5	-	-

UNIT – I: Gas Exchange Processes

Inlet and exhaust processes in the four stroke cycle volumetric efficiency quasi static effects combined quasi static and dynamic effects variation with speed and valve area and timing-flow through valves poppet valve geometry and timing flow rate and discharge efficient, residual gas fraction exhaust gas flow rate and temperature variation, scavenging in wlike eyelid engines, scavenging parameters and mdeluctual scavenging processes. Flow through parts supercharging and turbo changing methods of power buying abusive relationships compressors, turbines wave compression devices.

UNIT – II: Charge Motion Within The Cylinder

Intake Jet Flow, Mean velocity and turbulence characteristics definitions application to engine velocity data swirl swirl measurement, swirl generation during induction swit modification within the cylinder squish pre chamber engine flow crevice flows and blowby News nerated by piston-cylinder wall interaction

UNIT – III: Combustion In S.I And C.I Engines

Review of normal and abnormal combustion in SI and CI engine cyclic variation in combustion of St engine analysis of cylindrical pressure data in SI and CI engine. EMP Flix SI engines common rail fuel injection system in Ci engines fuel spray behavior in CI engine

UNIT – IV: Electric Vehicles

Introduction Limitations of IC Engines as prime mover. History of EV, components of EV. and AC electric machines: Introduction and basic structure, Electric vehicle drive train, advantages and limitations Permanent magnet and switched reluctance motors.

UNIT – V: Hybrid Vehicles

Configurations of hybrid, Series and parallel, advantages and limitations, Hybrid drive trains, sizing of components Initial acceleration, rated vehicle velocity, Maximum velocity and maximum gradeability, Hydrogen: Production, Hydrogen storage systems, reformers.

Fuel Cell Vehicles: Introduction, Fuel cell characteristics, Thermodynamics of Fuel cells, Fuel cell types; emphasis on PEM fuel cell.

Text Books:

- 1 Internal Combustion Engine Fundamentals, J.B. Heywood, Mc Graw Hill Co, (ISBN: 978-1259002076)
- 2 Build your own electric vehicle, Seth Leitman and Bob Brant. McGraw Hill, Co, 3 rd edition, (ISBN: 978-0071770569)

Reference Books:

- 1 Engineering Fundamentals of IC Engine, H.N. Gupta, 2nd edition PHI Pvt. Ltd. (ISBN: 9788120346802)
- 2 PEM Fuel Cells-Theory and Practice, F. Barbir Elsevier Academic Press, (ISBN: 9780128102398)

Web Links:

- 1 <http://nptel.ac.in/courses/112101097/>
- 2 www.thermopedia.com/content/786

CAD TOOLS FOR VLSI DESIGN

Course Code:242EC028

L	T	P	C
3	0	0	3

Course Outcomes:

At the end of the Course, Student will be able to:

- CO1: Comprehend the insight of CAD Tools in modern design.
- CO2: Develop combinational logic circuits by using CAD tools
- CO3: Build sequential logic circuits using Verilog HDL operators
- CO4: Analyze the performance of logic schematics using CAD simulation tools
- CO5: Infer the performance of logic circuits in terms of DRC, LVS and PEX.

Mapping of Course Outcomes with Program Outcomes:

CO/PO	PO 1	PO 2	PO 3	PO 4	PO 5	PO 6
CO1	1	3	1	2	2	1
CO2	2	3	1	2	1	2
CO3	2	2	3	2	2	1
CO4	2	3	1	2	2	1
CO5	2	3	2	2	2	1

Mapping of Course Outcomes with Program Specific Outcomes:

CO/PSO	PSO1	PSO2	PSO3
CO1	2	3	1
CO2	2	3	1
CO3	2	3	1
CO4	2	3	1
CO5	2	3	1

UNIT – I

Understanding the working platform with Xilinx Vivado and its device, family and package Selection. Design and Implementation of Combinational Circuits Priority Encoder and Comparator using data flow & structural style.

UNIT – II

Design and Implementation of Sequential Circuits to detect a given sequence using with and without overlapping (mealy & Moore machines). Design and Implementation of a traffic light controller in three road & four road junctions.

UNIT – III

Exercise on Concatenation, Replication operators, Reduction and Conditional operators in Verilog HDL. Performance characteristics of an n-channel and p-channel MOSFET.

UNIT – IV

Working with Schematic for Ring Oscillator with variable amounts of Pull up to pull down ratios. Design a full adder by instantiating the logic gates. Make a comment on design style on its performance.

UNIT – V

Design a NAND gate by using NMOS, PMOS and CMOS technologies and make a comment on its performance. Design a Schematic, stick and layout for given logic.

Text Books:

1. S. M. Kang and Y. Leblebici, CMOS Digital Integrated Circuits : Analysis and Design, Third Edition, MH, (ISBN Number-0072460539)
2. Plummer, Deal , Griffin “Silicon VLSI Technology: Fundamentals, Practice & Modeling”PH, (ISBN Number-0130850373)

Reference Books:

1. P. VanZant , “Microchip Fabrication”, 5th Edition, MH, (ISBN Number-6053901308)
2. R. J. Baker, H. W. Li and D. E. Boyce, CMOS Circuit Design, Layout and Simulation, PH, (ISBN Number-1119481511)

Web Links:

1. <https://themosisservice.com/university-support>
2. <https://youtu.be/OF3Zwfu6Ngc>
3. <https://newsroom.ibm.com/2021-05-06-IBM-Unveils-Worlds-First-2->

FPGA DESIGN FOR EMBEDDED SYSTEMS

Course Code: 242EC029

L	T	P	C
3	0	0	3

Course Outcomes:

At the end of the Course, Student will be able to:

- CO1:** Outline the concepts of Embedded System and Hardware Description Languages
- CO2:** Develop an embedded system using FPGA
- CO3:** Explain FPGA platforms and cross development tools.
- CO4:** Illustrate Parallelism and scheduling concepts
- CO5:** Interpret the parallelism with in FPGA hardware core.

Mapping of Course Outcomes with Program Outcomes:

CO/PO	PO 1	PO 2	PO 3	PO 4	PO 5	PO 6
CO1	1	1	3	1	-	-
CO2	3	-	2	-	-	-
CO3	1	-	2	3	-	-
CO4	1	-	2	3	-	-
CO5	1	-	2	3	-	-

Mapping of Course Outcomes with Program Specific Outcomes:

CO/PSO	PSO1	PSO2	PSO3
CO1	1	2	-
CO2	-	2	2
CO3	-	2	2
CO4	2	-	2
CO5	2	-	2

UNIT – I: Embedded System Overview & Hardware Description Languages

H/W-FPGA-Embedded SoC and use of VLSI circuit technology-platform FPGA's-Altera, Cyclone, Hardware Description Languages - VHDL , Verilog , Other High-Level HDLs, From HDL to Configuration Bit-stream.

UNIT – II: System Design using FPGA

Principles of system design-Design quality, Modules and interfaces, Abstraction and state, Cohesion and coupling, Designing and Reuse, Control flow graph, Design-Origins of platform FPGA designs.

UNIT – III: FPGA Platform

Components, adding to platform FPGA systems, assembling custom compute cores. Software Design-System Software Options, Root File system, Cross-Development Tools, Monitors and Boot-loader.

UNIT – IV: Partitioning, Scheduling & Communication

Overview of Partitioning Problem, Analytical Solution to Partitioning-Basic definitions, expected performance gain, resource considerations, Analytical Approach, Communication-Invocation/Coordination, Transfer of State, Practical Issues- Profiling Issues, Data Structures Manipulate Feature Size.

UNIT – V: Spatial Design

Principles of Parallelism-Identifying Parallelism - Spatial Parallelism with Platform FPGAs Parallelism within FPGA Hardware Cores, Parallelism within FPGA Designs.

Text Books:

1. Embedded Systems Design with Platform FPGAs, Ron Sass, Andrew G Schmidt Principles and Practices, First Edition, Tata McGraw Hill, India, ISBN Number-0123743338
2. Digital Systems design using VHDL, Charles H Roth. Jr, Re-Print, PWS publishing company (Thomson Books), USA, ISBN Number-9788131518304

Reference Books:

1. Design with VHDL, V A. Padroni Circuit First Edition, MIT Press Cambridge, England, ISBN Number-0262162245
2. FPGA Based System Design, Wayne Wolf, First Edition, Prentices Hall Modern Semiconductor Design Series, USA, ISBN Number-0131424610

Web Links:

1. <https://www.coursera.org/learn/intro-fpga-design-embedded-systems>
2. <https://www.colorado.edu/ali/fpga-design-embedded-systems-specialization>

ARTIFICIAL INTELLIGENCE

Course Code: 242CS030

L	T	P	C
3	0	0	3

Course Outcomes:

At the end of the Course, Student will be able to:

- CO 1: Describe fundamentals of Artificial Intelligence and its applications
- CO 2: Solve basic AI based problems and construct logical building blocks for problem Formulation
- CO 3: Apply various logical systems inferencing different logical problems.
- CO 4: Illustrate knowledge representation using predicate logic and predicate rules.
- CO 5: Design expert systems that leverage domain knowledge effectively.

Mapping of Course Outcomes with Program Outcomes:

CO/PO	PO1	PO2	PO3	PO4	PO5	PO6
CO1	2	1	-	-	1	-
CO2	2	1	2	-	1	-
CO3	2	1	2	2	1	2
CO4	2	1	2	-	1	-
CO5	2	1	-	-	1	-

Mapping of Course Outcomes with Program Specific Outcomes:

CO/PSO	PSO1	PSO2
CO1	-	-
CO2	-	-
CO3	-	-
CO4	-	-
CO5	-	-

UNIT – I: Introduction to Artificial Intelligence:

Introduction, History, Intelligent Systems, Foundations of AI, Applications, Tic-Tac-Toe Game playing, Development of AI Languages, Current trends in AI

UNIT – II: Problem Solving: State-Space Search And Control Strategies:

Introduction, General Problem Solving, Characteristics of problem, Exhaustive Searches, Heuristic Search Techniques, Iterative- Deepening A*, Constraint Satisfaction.

Problem Reduction and Game Playing: Problem Reduction, Game Playing, Minimax algorithm, Alpha- Beta Pruning, Two-player perfect information games.

UNIT – III: Logic Concepts

Introduction, Propositional calculus, Proportional logic, Representing facts in logic, functions and predicates, Axiomatic System, Semantic Tableau System in Proportional logic, Resolution Refutation in proportional logic, predicate logic.

UNIT – IV: Knowledge Representation

Knowledge Representation Using Predicate logic, Knowledge Representation using Semantic Network, Knowledge Representation using Frames.

Representing Knowledge Using Rules: Procedural Versus Declarative knowledge, Logic Programming, Forward versus Backward Reasoning

UNIT – V: Expert System

Representing and using Domain Knowledge, Reasoning with knowledge, Expert System Shells, Support for explanation examples, Knowledge acquisition-examples.

Text Books:

1. Artificial Intelligence- Saroj Kaushik, 1st edition CENGAGE Learning, (ISBN: 9789355730428).
2. Artificial intelligence, A modern Approach, Stuart Russel, Peter Norvig, Pearson Education Ltd, 2nd ed, (ISBN: 97881203238)
3. Artificial Intelligence- Elaine Rich, Kevin Knight, Shivashankar B Nair, 3rd ed, McGraw Hill Education, (ISBN-13. 9780070087705)

Reference Books:

1. Artificial intelligence structures and strategies for complex problem solving, George F Lugar, 5th Edition, Addison Wesley. ISBN-13: 978-0321263186

Web Links:

1. https://www.tutorialspoint.com/artificial_intelligence/index.htm/
2. [https://www.slideshare.net/slideshow/logic-in-ai/5005940//](https://www.slideshare.net/slideshow/logic-in-ai/5005940/)
3. <https://www.slideshare.net/slideshow/artificial-intelligence-3638681/3638681/>

MACHINE LEARNING TECHNIQUES

Course Code: 242CS031

L	T	P	C
3	0	0	3

Course Outcomes:

At the end of the Course, Student will be able to:

- CO1: Describe the need for AI and ML, and the types of ML algorithms..
- CO2: Apply regression techniques and dimensionality reduction methods.
- CO3: Implement and evaluate various classification techniques.
- CO4: Describe and implement Artificial Neural Networks.
- CO5: Utilize unsupervised learning methods for clustering and dimensionality reduction

Mapping of Course Outcomes with Program Outcomes:

CO/PO	PO1	PO2	PO3	PO4	PO5	PO6
CO1	2	1	-	-	-	-
CO2	2	1	2	-	-	-
CO3	2	1	2	2	-	2
CO4	2	1	2	-	-	-
CO5	2	1	-	-	-	-

Mapping of Course Outcomes with Program Specific Outcomes:

CO/PSO	PSO1	PSO2
CO1	-	-
CO2	-	-
CO3	-	-
CO4	-	-
CO5	-	-

UNIT – I

Introduction: Understanding the need for AI and Machine Learning (ML), AI & Data, Types of ML Algorithms: Supervised, Unsupervised Learning and semi supervised learning, reinforcement learning, evolutionary computation ML Model development life cycle Deep Learning for Human Like Learning

UNIT – II

Regression Techniques: Regression for prediction, Gradient Descent and Ascent, Learning with Momentum, Loss Functions, Over fitting and under fitting, Model evaluation techniques
 Types of Regression: Linear Regression,

UNIT – III

Classification Techniques: Naïve Bayes Classification: Bayesian Learning, Naïve Bayes Classification, MAP, Bayesian Belief Networks, Decision Tree, K-Nearest Neighbors Support Vector Machines: Hard Margin and Soft Margin, Kernels and Kernel Trick, Evaluation Measures for Classification Techniques

UNIT – IV

Classification Techniques: Naïve Bayes Classification: Bayesian Learning, Naïve Bayes Classification, MAP, Bayesian Belief Networks Decision Tree K-Nearest Neighbors Support Vector Machines: Hard Margin and Soft Margin, Kernels and Kernel Trick, Evaluation Measures for Classification Techniques

UNIT – V

Unsupervised Learning: Uses in Clustering, associations and dimensionality reduction Clustering, Hierarchical Agglomerative Clustering, k-means Algorithm

Text Books:

- 1 Machine Learning, Tom Mitchell, McGraw-Hill international editions, TMH, (ISBN: 0071154671)
- 2 Pattern Recognition and Machine Learning C. Bishop, Springer, (ISBN: 9781493938438)
- 3 Elements of Artificial Neural Networks , Kishan Mehrotra, Chilukuri Mohan and Sanjay Ranka, Penram International, (ISBN: 9780262133289).

Reference Books:

- 1 Pattern Recognition, Techniques and Applications , Rajjan Shinghal, OXFORD Higher Education , (ISBN:9780195676853)
- 2 Andrew Kelleher, Adam Kelleher, Applied Machine Learning for Data Scientist and Software engineers, Addison-Wesley Professional, (ISBN:9780134116549)

Web Links:

- 1 https://onlinecourses.nptel.ac.in/noc21_cs24/preview/
- 2 <https://www.udemy.com/course/machinelearning/>

VALUE EDUCATION

Course Code: 242AC001

L T P C
2 0 0 0

Course Outcomes:

At the end of the Course, Student will be able to:

- CO 1: Understand value of education and self- development.
- CO 2: Explain the need of good values in students.
- CO 3: Developing the overall personality.
- CO 4: Explain the need of character in a student.

Mapping of Course Outcomes with Program Outcomes:

CO/PO	PO1	PO2	PO3	PO4	PO5	PO6
CO1	2	1	-	-	2	-
CO2	3	2	1	1	3	-
CO3	3	3	2	2	2	-
CO4	2	1	1	1	2	-
CO5	3	2	2	2	2	-

Mapping of Course Outcomes with Program Specific Outcomes:

CO/PSO	PSO1	PSO2
CO1	-	-
CO2	-	-
CO3	-	-
CO4	-	-
CO5	-	-

UNIT – I

Values and self-development –Social values and individual attitudes. Work ethics, Indian vision of humanism, Moral and non- moral valuation. Standards and principles, Value judgements.

UNIT – II

Importance of cultivation of values, Sense of duty, Devotion, Self-reliance, Confidence, Concentration. Truthfulness, Cleanliness, Honesty, Humanity. Power of faith, National Unity, Patriotism. Love for nature, Discipline

UNIT – III

Personality and Behavior Development - Soul and Scientific attitude. Positive Thinking. Integrity and discipline, Punctuality, Love and Kindness, Avoid fault Thinking, Free from anger, Dignity of labour, Universal brotherhood and religious tolerance, True friendship.

UNIT – IV

Happiness Vs suffering, love for truth, Aware of self- destructive habits, Association and Cooperation, Doing best for saving nature.

UNIT – V

Character and Competence –Holy books vs Blind faith, Self-management and Good health, Science of reincarnation, Equality, Nonviolence, Humility, Role of Women, All religions and same message, Mind your Mind, Self-control, Honesty, Studying effectively.

Text Books:

1. Chak ro borty, S.K. “Values and Ethics for organizations Theory and practice”, Oxford University Press, New Delhi. (ISBN: 9780195643077)

Reference Books:

1. Value Education and Professional Ethics by R.P. Shukla (ISBN: 9788183560995)
2. Value Education: A Textbook for Schools by Dr. N. Venkataiah (ISBN: 9788120731965)
3. Value Education: Theory and Practice by G. Rajagopal (ISBN: 9788182475191)

Web Links:

1. <https://nptel.ac.in/courses/109/104/109104068/>
2. <https://nptel.ac.in/courses/109/105/109105116/>
3. <https://nptel.ac.in/courses/109/104/109104107/>

RESEARCH METHODOLOGY

Course Code: 242AC002

L	T	P	C
2	0	0	0

Course Outcomes:

At the end of the Course, Student will be able to:

- CO 1: Explain the characteristics and process of research.
- CO 2: Choose the research problem by applying problem identification techniques.
- CO 3: Develop and execute research design process.
- CO 4: Show the results of research process adhering to professional ethics.
- CO 5: Analyze the results of research using statistical measures of central tendency & coefficient of variation, correlation and regression

Mapping of Course Outcomes with Program Outcomes:

CO/PO	PO1	PO2	PO3	PO4	PO5	PO6
CO1	2	1	-	-	2	-
CO2	3	2	1	1	3	-
CO3	3	3	2	2	2	-
CO4	2	1	1	1	2	-
CO5	3	2	2	2	2	-

Mapping of Course Outcomes with Program Specific Outcomes:

CO/PSO	PSO1	PSO2
CO1	-	-
CO2	-	-
CO3	-	-
CO4	-	-
CO5	-	-

UNIT – I: Meaning of Research

Function of Research - Characteristics of Research – Steps involved in Research – Research in Pure and Applied Sciences - Inter Disciplinary Research. Factors which hinder Research – Significance of Research - Research and scientific methods – Research Process– Criteria of good Research – Problems encountered by Researchers – Literature review.

UNIT – II: Identification of Research Problem

Selecting the Research problem – Necessity of defining the problem – Goals and Criteria for identifying problems for research. Perception of Research problem – Techniques involved in defining the problem.

UNIT – III: Research Design

Formulation of Research design – Need for Research design – Features of a good design – Important concepts related to Research design.

UNIT – IV: Interpretation and Report Writing

Meaning and Technique of interpretation – Precautions in interpretation, Significance of report writing – Different steps in writing a report – Layout of a Research report.

UNIT – V: Statistical Techniques and Tools

Introduction of statistics – Functions – Limitations – Measures of central tendency - Arithmetic mean – Median – Mode – Standard deviation – Co-efficient of variation (Discrete series and continuous series) – Correlation – Regression.

Text Books:

1. Research Methodology Methods & Techniques, C.R. Kothari – New Age international Publishers (ISBN: 9789386649225).
2. A Hand Book of Methodology of Research, Rajammall, P. Devadoss and K. Kulandaivel, RMMVidyalaya press.(ISBN: 9780367135720)

Reference Books:

1. Thesis and Assignment Writing, J. Anderson, Wiley Eastern Ltd.(ISBN: 9780471339274)
2. Research Methodology, Mukul Gupta, Deepa Gupta – PHI Learning Private Ltd., New Delhi. (ISBN: 9788120343818)
3. Fundamentals of Mathematical statistics, S.C. Gupta and V.K. Kapoor, Sultan Chand & Sons, New Delhi.(ISBN: 9788180545283)

Web Links:

1. <https://nptel.ac.in/courses/127106227>
2. <https://www.coursera.org/learn/research-methodologies>
